

INSTALLATION

OPERATION

MAINTENANCE

MELLTRONICS DRIVES
ES 2700

SINGLE PHASE NON-REGENERATIVE
DC DRIVE CONTROLLER
1/4 HP TO 5 HP



MAIL: PO BOX 2368
INDIAN TRAIL, NC 28079-2368
SHIPPING: 3479 GRIBBLE ROAD
MATTHEWS, NC 28104-8114

PHONE: 704-821-6651
www.melltronics.com

SAFETY WARNINGS:

Improper installation or operation of this drive control may cause serious injury to personnel or equipment. Before you begin installation or operation of this equipment you should thoroughly read this instruction manual and any supplementary operating instructions provided. The drive must be installed and grounded in accordance with local and national electrical codes. To reduce potential of electric shock, disconnect all power sources before initiating any maintenance or repairs. Keep fingers and foreign objects away from ventilation and other openings. Keep air passages clear. Potentially lethal voltages exist within the control unit and connections. Use extreme caution during installation and start-up.

BRANCH CIRCUIT PROTECTION:

Branch circuit protection is to be provided by *end user*, if not included.

INITIAL CHECKS:

Before installing the drive control, check the unit for physical damage sustained during shipment. Remove all shipping restraints and padding.

INSTALLATION LOCATION OF CONTROL:

Controls are suitable for most factory areas where industrial equipment is installed. The control and operator's control station should be installed in a well-ventilated area. Locations subject to steam vapors or excessive moisture, oil vapors, flammable or combustible vapors, chemical fumes, corrosive gases or liquids, excessive dirt, dust or lint should be avoided unless an appropriate enclosure has been supplied or a clean air supply is provided to the enclosure. The location should be dry and the ambient temperature should not exceed 104°F for an enclosed unit or 131°F for a chassis mount unit. If the mounting location is subject to vibration, the enclosure should be shock-mounted.

If the enclosure has a ventilating fan, avoid, wherever possible, an environment having a high foreign-matter content; otherwise the filters will have to be changed more frequently or micron-filters installed. Should a control enclosure require cleaning on the inside, a low pressure vacuum cleaner is recommended, not an air hose, because of the possible oil vapor in the compressed air and its high pressure.

ES2700 – RECEIVING INFORMATION

Please record the following before installing the unit and use these numbers when communication with the factory.

MODEL NAME _____

PART NUMBER _____

SERIAL NO. _____

REVISION _____

MODIFICATIONS _____

ACCEPTANCE:

Carefully inspect shipment upon arrival and check items with packing list. Shortage or damage should be reported promptly to the carrier and your distributor.

TABLE OF CONTENTS

SECTION 1 SAFETY..... 5

1.1 INTRODUCTION.....5

1.2 GENERAL DESCRIPTION.....5

1.3 TYPICAL PACKAGING.....5

1.4 EQUIPMENT IDENTIFICATION.....6

SECTION 2 CONTROL SPECIFICATIONS AND FEATURES 7

2.1 EQUIPMENT RATINGS.....7

2.2 PERFORMANCE FEATURES.....7

2.3 PROTECTIVE FEATURES.....8

2.4 PERFORMANCE SPECIFICATIONS.....8

2.5 OPERATING CONDITIONS.....8

2.6 ENVIRONMENTAL CONDITIONS.....8

2.7 ADJUSTMENTS.....9

2.8 CONTROL DIMENSIONS AND WEIGHTS.....9

SECTION 3 FUNCTIONAL DESCRIPTION..... 10

3.1 GENERAL DESCRIPTION..... 10

3.2 POWER CONVERSION ASSEMBLY..... 10

3.3 REGULATOR ASSEMBLY..... 10

SECTION 4 INSTALLATION 13

4.1 SAFETY WARNINGS..... 13

4.2 INITIAL CHECKS..... 13

4.3 DETERMINING THE CONTROL LOCATION..... 13

4.4 INSTALLING CHASSIS MOUNT CONTROLS..... 13

4.5 INSTALLING ENCLOSED CONTORLS..... 13

4.6 POWER WIRING..... 13

4.7 CONTROL LOGIC WIRING..... 14

4.8 SIGNAL WIRING..... 14

4.9 CIRCUIT BOARD INTERCONNECTIONS..... 14

4.10 INSTALLING MODIFICATIONS..... 15

SECTION 5 OPERATION AND START-UP PROCEDURE 18

5.1 INTRODUCTION..... 18

5.2 OPERATOR CONTROLS..... 18

5.3 ADJUSTMENTS..... 21

5.4 JUMPER PROGRAMMING..... 22

5.5 START-UP PROCEDURE..... 24

SECTION 6 MAINTENANCE AND TROUBLESHOOTING..... 27

6.1 IMPORTANT SAFEGUARDS..... 27

6.2 ROUTINE MAINTENANCE..... 27

6.3 TROUBLESHOOTING..... 27

6.4 CORRECTIVE ACTION FOR DRIVE MALFUNCTIONS..... 28

6.5 SCR REPLACEMENT..... 30

SECTION 7 ORDERING SPARE PARTS..... 31

SECTION 8 SUPPLEMENTARY TECHNICAL INFORMATION 32

SECTION 9 WARRANTY..... 39

LIST OF TABLES

Table 1: Armature Circuit Rating Table..... 7
 Table 2: MELLTRONICS ES-2700 Field Data..... 7
 Table 3: MELLTRONICS ES-2700 Weights and Dimensions 9
 Table 4: Armature Current Overload Scaling..... 23
 Table 5: Recommended Spare Parts for the ES-2700 31
 Table 6: Terminal Strip Connections..... 33
 Table 7: Jumper Programming Quick Guide..... 33

LIST OF FIGURES

Figure 1: Typical Chassis Mount Control 5
 Figure 2: Typical MELLTRONICS ES-2700 Nameplate 6
 Figure 3: Product Nameplate Location 6
 Figure 4: ES-2700 Block Diagram 12
 Figure 5: Connector J1 Pin Assignments..... 15
 Figure 6: User Connection Diagram 16
 Figure 7: Upper PC Board..... 17
 Figure 8: Lower PC Board..... 17
 Figure 9: Inverse Time Trip Overload Characteristics 18
 Figure 10: Upper Control Board Operating Features..... 20
 Figure 11: Stability Effects on the Velocity Profile 21
 Figure 12: Lower PC Board Details 26
 Figure 13: SCR Location..... 30
 Figure 14: Chassis Mount Control 32
 Figure 15: Enclosed Control..... 32
 Figure 16: Control Logic and Test Meter Connections 34
 Figure 17: Interconnect Diagram 272-1000-I, Sheet 1 35
 Figure 18: Interconnect Diagram 272-1000-I, Sheet 2 36
 Figure 19: Top PC Board Schematic - Diagram 272-1000..... 37
 Figure 20: Bottom PC Board Schematic - Diagram 272-1005..... 38

SECTION 1 SAFETY

1.1 INTRODUCTION

This instruction manual contains installation information, operating instructions and troubleshooting procedures for the MELLTRONICS ES-2700 Adjustable Speed Non- Regenerative DC Motor Control. A comprehensive description of the MELLTRONICS ES-2700 control with detailed product specifications and a complete description of all customer selectable functions and customer installable option kits is included.

The information in this instruction manual will describe all drive system set-up and operating procedure for most drive applications. Also provided is all the information required by the customer to install and maintain a MELLTRONICS ES-2700 control. Additional drive system set-up and operating information may be required in some applications. This information will normally be supplied in the form of a system schematic and system interconnection diagrams.

Before beginning installing and before performing any start-up or maintenance on the drive system read this instruction manual in its entirety .

1.2 GENERAL DESCRIPTION

The MELLTRONICS ES-2700 is a high performance, non-regenerative DC motor control. Included are many standard features that are available only as options on many other regenerative drives. Accessibility to all important internal regulator points is provided by terminals on the control. This permits the MELLTRONICS ES-2700 to be used in custom engineered applications, as well as in standard speed regulated applications.

The MELLTRONICS ES-2700 controls a DC motor's speed or torque by varying the DC voltage applied to the motor's armature. Rectilinear phase control assures stable operation at low speeds and low torque where other controls may exhibit instability.

The MELLTRONICS ES-2700 control converts single phase AC input power to variable voltage DC output power. In speed regulated applications, the DC output voltage varies as a function of an input reference voltage. (Typically, this input reference voltage is provided by an operator adjustable potentiometer). Changing the speed reference (potentiometer setting) results in a motor speed change. In torque regulated applications, the DC output current varies as a function of an input reference voltage. Changing the torque reference (potentiometer setting) changes the current supplied to the motor and results in a change in motor torque output.

The MELLTRONICS ES-2700 is a versatile control. Simple jumpered programming allows the

MELLTRONICS ES-2700 to operate from either 120 or 240 volt AC input power at 50 or 60 Hz. Additional jumpers program the control to operate as either a speed regulator with armature voltage or as a torque regulator with armature current feedback.

The entire 1/4 to 5HP range of applications is covered by two control models (See Table 1). Drive current limit and inverse time overload protective circuits for ratings within this range are calibrated by means of a jumper change on the main printed circuit board.

Included in the MELLTRONICS ES-2700 control are many built-in features. Motor field economy and separately adjustable rates of acceleration and deceleration are included on all units. If desired, the built-in Accel-Decel control ramps can be by-passed completely by a jumper change on the control. Current compounding can be added to the speed regulator by changing another jumper position. Current limit is normally set by a potentiometer located on the main printed circuit board, but if desired, it can be adjusted using a remote mounted potentiometer or a customer supplied voltage signal. An output signal is available for use with one of the MELLTRONICS ES-2700 ammeter kits to provide an indication of drive output current without the addition of an ammeter shunt.

1.3 TYPICAL PACKAGING

The normal MELLTRONICS ES-2700 control is chassis mounted non-enclosed control suitable for subpanel mounting inside a customer furnished control enclosure. (see Figure 1)

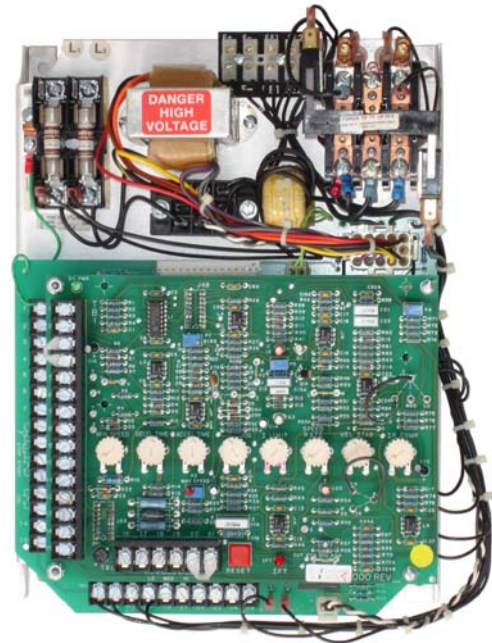

Figure 1: Typical Chassis Mount Control

Typically MELLTRONICS ES-2700 controls are furnished without operator's devices. Terminals are provided on the basic MELLTRONICS ES-2700 control for connection of one or more of the following operator's devices:

- Jog Push-button
- Remote Current Limit Potentiometer
- Speed Adjust Potentiometer
- Start Push-button
- Stop Push-button

Customer requirements may dictate that the operator's devices be mounted on the door of the enclosure. For these applications, see schematic and interconnection diagrams furnished with your control for specific variations in packaging.

1.4 EQUIPMENT IDENTIFICATION

Identification of your drive control completely and accurately is necessary when you contact Melltronics Industrial to order spare parts or request assistance in service. Every MELLTRONICS ES-2700 includes a product nameplate located on the right side of the chassis. Record both the part number and serial number for your future reference.

MODEL		ES2700	
ACINPUT			
V AC	120/240	A	17
HZ	50/60	PH	1
MAX DC OUT			
V DC	90/180	A	10
HP	1-2	KW	
FIELD OUT			
V FL	100/200	A	3
PN			
SC	2710-1000-I		
SN			

Figure 2: Typical MELLTRONICS ES-2700 Nameplate

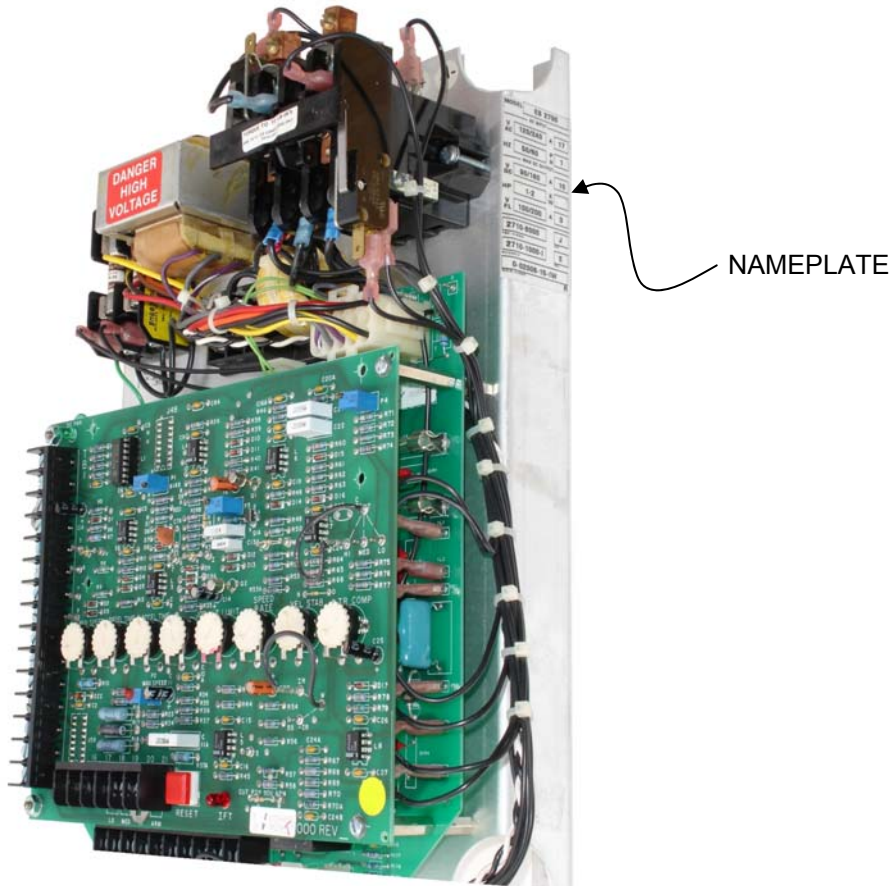

Figure 3: Product Nameplate Location

**SECTION 2
CONTROL SPECIFICATIONS AND FEATURES**

2.1 EQUIPMENT RATINGS

The MELLTRONICS ES-2700 was designed so that a minimum number of different models could be used in a wide variety of different drive applications.

Two ES-2700 control models cover the entire ¼ to 5 HP range of DC drive applications. ES-2700 controls are reconnectable for 120VAC or 240VAC single phase input at either 50 or 60Hz. One control model covers ¼ through 1 HP applications at 120VAC input and ½ through 2 HP applications at 240VAC input. A second control model covers 3 to 5HP applications at 240VAC input. Drive current limit and inverse time overload protective circuits are calibrated for the application by jumper on the main PC board.

Table 1 lists the AC input and DC output current ratings by control part number and motor horsepower for all possible combinations.

Table 1: Armature Circuit Rating Table

Control Part No.	Horsepower		AC Input Amps @Full Load	DC Armature Amps @ Full Load
	120 VAC	240 VAC		
272-8000	1/4	1/2	4.2	3
	1/3	—	5.6	4
	—	3/4	5.6	4
	1/2	1	8.5	6
	3/4	1 1/2	11	8
	1	2	14	10
272-8001	—	3	21	14
	—	—	28	20
	—	5	38	25

A fixed voltage unregulated DC motor field supply is provided on all MELLTRONICS ES-2700 controls. The DC voltage output level is a function of the AC voltage input level. Field data for the MELLTRONICS ES-2700 control is tabulated in Table 2.

Table 2: MELLTRONICS ES-2700 Field Data

Voltage:	100 VDC with 120 VAC input 200 VDC with 240 VAC input
Current:	3 amperes maximum

2.2 PERFORMANCE FEATURES

Every ES-2700 control includes the following standard features and functions:

- **Current (Torque) Regulator** - One percent accuracy armature current regulator allows the operator to control motor torque instead of speed.

- **Common Control Circuit Boards** – All ES-2700 controls utilize the same PC board regardless of HP, voltage, frequency or control mode.
- **Field Economy** - Promotes longer life for wound field DC motors. Easily by-passed or time delayed to meet specific application requirements.
- **Inner Current Loop Regulator** - Inherent high band width capability for fast response.
- **Circuit Board Indicators** - Light emitting diodes (LEDs) on the main printed circuit board indicate:
 - DC Overload
 - DC Power ON
 - Field Loss
 - Jog Mode
 - Instantaneous Overcurrent Trip
 - Run Mode
 - SCRs Being Gated
- **Ammeter Output** - Motor current can be indicated with the simple addition of a remote meter.
- **Isolated Control Circuitry** - Provides complete isolation of the control and regulator circuitry from the AC power bus for protection in the event of a ground fault. The speed potentiometer, ammeter and tachometer are not at line potential. Complete system compatibilities is also possible without additional isolation accessories.
- **Dual Frequency Operation** - Controls may be operated from 50 or 60Hz power supplies by simple jumper change.
- **Exclusive Static Adjustable Current Limit** - Permits static setting of the desired current limit value without applying DC power and without a connected output load when the optional test meter is connected.
- **Jog Set at Preset Speed** - Separately adjustable from zero to 50% of base speed.
- **Negative IR Compensation** - enables this drive to operate in load sharing applications. This feature becomes available by jumper connection.
- **Speed Regulator** – Two percent accuracy using armature voltage feedback with IR compensation of 1% accuracy with tachometer feedback. Regulation may be improved by selecting the proper motor mounted tachometer.
- **Separately Adjustable Linear Accel/Decel Control** - Two ranges; 0.2-4 seconds and 2-30 seconds.
- **Solid State Full Wave Power Bridge** - Provides generously rated power semiconductors for maximum reliability and long life.
- **Standard Adjustments** – Maximum speed, minimum speed, IR compensation, acceleration time, deceleration time, current limit, jog speed, velocity stability, speed rate and current stability.
- **Remote Current Limit** - Available by the simple addition of a potentiometer of DC voltage input.

- **SCR Trigger Circuits** - Pulse transformer isolated, hard firing, high frequency “burst” type pulse train output from individually gated oscillators insures SCR conduction regardless of the effects of line notching on the incoming AC power line.
- **AC Line Filter and Transient Voltage Suppressor Network** - Eliminates interaction between other drives or AC equipment.
- **Power Supplies** – Each ES-2700 contains an internal 115 VAC power supply to power the DC loop contactor and drive logic relays. Internal ±24VDC, ±15VDC and a regulated –10VDC power supply are also included.

2.3 PROTECTIVE FEATURES

The following list identifies the protective features of the ES-2700.

- **DC Overload (Armature)** - Senses over-current conditions with inverse time shutdown.
- **Fault Trip Circuit** - Visual indication of the fault condition is provided when a DC overload, field loss, or instantaneous over-current conditions occurs. Protective circuits are designed to quickly shut the drive down whenever a drive fault condition occurs. A fault trip circuit prevents unintended drive restart after a fault has occurred and must be reset before the drive can run again.
- **Field Loss Protection** - Protects against runaway due to loss of motor field by shutting down the drive.
- **Double Break DC Armature Loop Contactor** - Full rated and fully sequenced contactor assures positive disconnect of DC motor when the stop push-button is pushed or whenever an under-voltage condition occurs.
- **High Speed Current Limiting SCR Semiconductor Fuses** - Gives the ultimate in fuse coordination and protection of the SCRs and motor with positive circuit clearing on both AC and DC faults.
- **Reactors, Snubber Networks** - Prevents interaction and SCR DV/DT failures, due to line spikes and transients. Provides DI/DT protection during SCR turn-on and aids in SCR turn-off during SCR commutation, therefore minimizing the effects of AC power-line notching.
- **Instantaneous Overcurrent Protection** – Senses armature fault currents quickly to protect both semi-conductors and motors against damaging current levels.

NOTE
 Additional electrical equipment to insure proper control operation may be required for severe system applications. For further information, contact Melltronics Industrial.

2.4 PERFORMANCE SPECIFICATIONS

- Controlled Speed Range:** 20:1 basic control. May be extended to 200:1 by modification
- Speed Regulation:**
- For a 95% Load Change:**
 - Voltage Regulated: 2-5% of maximum speed
 - Speed Regulated: 1% of maximum speed with any DC tachometer.
- For All Other Variables:**
- Voltage Regulated: Changes up to 15% of top speed can result from temperature variations, voltage and frequency variations, and drift.
 - Speed Regulated:
 - 1% of maximum speed with any DC tachometer
 - 2% of maximum speed with any AC tachometer

NOTE
 Speed regulation may be modified to achieve 0.1% due to a 95% load change and 0.15% due to all other variables.

Overload Capacity: 150% of related current for 1 minute
 Service Factor: 1.0

2.5 OPERATING CONDITIONS

- Rated Line Voltage: 120 or 240VAC , Single-Phase
- Line voltage Variations: ±10%
- Rated Line Frequency: 50 or 60Hz
- Line Frequency Variations: ±2Hz

2.6 ENVIRONMENTAL CONDITIONS

- Storage Temperature: -30° C to 65° C (-20° F to 150° F)
 - Ambient Temperature (Enclosed Control): 0° C to 40° C (32° F to 104° F)*
 - Ambient Temperature (Chassis Mount Control): 0° C to 55° C (32° F to 131° F)*
 - Altitude: Sea level to 3300 feet *(1000 meters)
 - Relative Humidity: 0 to 95%
- *Operation at elevated temperature and higher altitudes requires derating of the control.

2.7 ADJUSTMENTS

The MELLTRONICS ES-2700 control includes a number of potentiometers that may require adjustment during drive installation and start-up. These adjustment potentiometers are located on the main (regulator) PC board.

- **Vel. Stability** User adjusted for best results
- **Deceleration Time** User adjustable from 0.2-4 sec. or 2-30 sec. (selectable)
- **Acceleration Time** User adjustable from 0.2-4 sec. or 2-30 sec. (selectable)
- **Maximum Speed** User adjustable from 70-130% of rated speed.
- **Jog Speed** User adjustable from 0-50% of rated speed
- **Current Stability** User adjustable for best results
- **Speed Rate** User adjustable for best results.
- **I R Compensation** User adjustable from 0-15% of rated voltage.
- **Min Speed** User adjustable from 0 to 30% of rated speed.
- **I Limit** User adjustable from 0-150% of selected current range

Included on the MELLTRONICS ES-2700 are several additional adjustment potentiometers. These potentiometers are all factory set and normally do not require further adjustment.

CAUTION
ANY ALTERNATION TO FACTORY-ADJUSTED POTENTIOMETERS MAY CAUSE EQUIPMENT DAMAGE AND/OR MACHINERY PROCESS PROBLEMS. FOR FURTHER ADJUSTMENTS, CONTACT: MELLTRONICS INDUSTRIAL, INC.

2.8 CONTROL DIMENSIONS AND WEIGHTS

Table 3 gives the approximate weight and dimensions for various MELLTRONICS ES-2700 controls. Figure 14 shows the outline and mounting dimensions for these MELLTRONICS ES-2700 controls.

Table 3: MELLTRONICS ES-2700 Weights and Dimensions

Control Type	Approximate Weight (lbs)	Approximate Dimensions
Chassis Mount	10	13.0 x 9.5 x 4.75
Chassis Mount with Test Meter	10	13.0 x 9.5 x 7.0

SECTION 3 FUNCTIONAL DESCRIPTION

The ES-2700 is a non-regenerative DC motor control which consists of two basic functional blocks: a power conversion assembly and a regulator assembly.

3.1 GENERAL DESCRIPTION

The power conversion assembly consists of two silicon controlled rectifiers (SCRs) and two diodes connected in a full wave bridge configuration, with a third “freewheeling” diode connected across the armature output terminals of the bridge. Normally reverse biased, this “freewheeling” diode conducts only when both SCRs have been commutated off, allowing the current in the armature circuit a path to circulate.

The Regulator Assembly includes all of the electronic circuitry used to control (provide gating signals to) the Power Conversion Assembly. The regulator used in the ES-2700 employs two control loops – an outer velocity loop and an inner current loop. There are several advantages inherent in a DC motor control that employs this dual control loop concept. First of all, the inner current loop can easily and effectively be used to limit DC motor armature current. This protects the motor, the power bridge, and the fuses during stable drive operation under varying load conditions. Another advantage of a DC motor control that employs an inner current loop is the ease with which it can be converted from speed regulated drive to a torque regulated drive. This provides application flexibility that would not otherwise be available.

In the following section, the ES-2700 will be analyzed and described using the functional block diagram shown in Figure 4.

3.2 POWER CONVERSION ASSEMBLY

Incoming AC power is applied to the ES-2700 control at terminals L1 and L2. A pair of current limiting type fuses (1FU and 2FU) provides AC line short circuit protection and serves to protect the SCRs from DC fault currents. AC line power is distributed within the ES-2700 control to three major functional blocks: the power conversion assembly, the DC motor field supply and the control power supply.

The power conversion assembly consists of a single phase controlled, full wave rectified, SCR power conversion assembly. The output of the power conversion assembly is connected to the DC motor armature through a DC loop contactor (M). The DC loop contactor provides a positive means of disconnecting the DC motor armature from the power conversion assembly in the event of a drive fault.

The DC motor field supply rectifies AC line voltage to produce a fixed DC voltage that may be connected to the field windings of a wound field DC motor. The field power supply produces an output of 200VDC with 240VAC input or 100VDC with a 120VAC input. An auxiliary contact (MAUX) “half waves” the field power

supply anytime the DC loop contactor is opened. This reduces the field voltage applied to the DC motor (field economy) and helps to increase motor life in the applications where the motor field remains energized while the motor is stopped.

The control power supply assembly steps down the incoming AC line voltage, and then rectifies filters and regulates it to provide two DC power sources ($\pm 24\text{VDC}$ and $\pm 15\text{VDC}$) that are used internally by the ES-2700 regulator assembly.

A -10VDC output is also produced which may be used in conjunction with an external potentiometer to create a drive reference signal. The control power supply assembly includes a fused and isolated 115VAC power source that is used to operate the control logic relays and DC loop contactor.

All of the remaining functional blocks shown in Figure 4 are functional blocks associated with the ES-2700 regulator assembly. An overview of the ES-2700 regulator assembly follows.

3.3 REGULATOR ASSEMBLY

The ES-2700 control works off of a zero to -10VDC reference signal. This input reference signal can represent either a DC motor speed reference or a DC motor torque reference depending on the placement of a terminal board jumper (this will be explained later). The input reference signal is usually introduced to the control at terminal #12 (TB-1) on the regulator (top) printed circuit board.

3.3.1 ACCEL/DECEL CIRCUIT

Terminal #12 is connected to the input of the ES-2700 accel/decel (reference ramp) circuit. This circuit controls the rate at which the drive reference can change. When a reference signal is applied to the input of the accel/decel circuit, the output of the accel/decel circuit changes at a linear rate with respect to time until the output of the accel/decel circuit TB-1, Terminal #3 is equal to its input (Terminal #12). The rate of change is adjustable and separate adjustments are provided for positive going and negative going reference changes. The accel/decel (ramp reference) circuit is most commonly used in speed regulated drive applications. If the operator rapidly changes the speed reference to the drive, the accel/decel circuit will limit the acceleration of deceleration rate to a rate that will not cause machine or process problems. The accel/decel (reference ramp) circuit can also be used in torque-regulated applications to limit the rate at which the torque reference to the drive can change.

The output of the accel/decel circuit (TB-1 Terminal #3) is usually connected to the velocity error amplifier input (Terminal #4) via a jumper connection at the customer terminal strip (TB-1). It is possible to bypass the accel/decel circuit completely by connecting

the drive input reference signal to Terminal #4 instead of terminal #12 and removing the jumper between Terminals #3 and #4. The accel/decel circuit is often by-passed in custom engineered drive applications..

3.3.2 VELOCITY ERROR AMPLIFIER

The velocity error amplifier circuit is used in speed regulated drive applications. It compares a velocity reference signal with a velocity feedback signal to determine whether the DC motor is operating faster or slower than its commanded velocity. The output of the velocity error amplifier circuit is used as a reference signal to the ES-2700's "inner current loop". The "inner current loop" directly controls DC motor armature current.

The feedback signal to the velocity error amplifier can be a signal proportional to DC motor armature voltage or it can be a signal from a DC tachometer generator. Armature voltage feedback is used in those applications where the speed regulation and drift characteristics (See section 2.4). The velocity feedback selection and scaling circuitry allows the control to be programmed for armature voltage feedback or tachometer feedback. It allows the control to be used with 90VDC or 180VDC motors (voltage regulated applications) or with a variety of tachometer voltage output levels (speed regulated applications). The velocity error amplifier circuit has one additional input, IR compensation.

3.3.3 IR COMPENSATION

The IR compensation network introduces an increase (or decrease) in the velocity reference proportional to motor armature current. The magnitude of the increase (or decrease) can be adjusted using the IR compensation potentiometer. On the ES-2700 the IR compensation signal can be either positive or negative.

Positive IR compensation increases the motor velocity reference as the motor armature current increases. Positive IR compensation is used in armature voltage regulated control applications to offset the natural tendency for the speed of a motor to decrease as the load on the motor increases. Positive IR compensation is generally not used in applications that employ tachometer feedback.

Negative IR compensation is just the opposite of positive IR compensation. It causes the motor velocity reference to decrease as motor armature current increases. When negative IR compensation is employed, the DC drive motor will function much like a compound wound DC motor would function in the same application. Negative IR compensation is used in "helper drive" applications where the speed of the drive must conform to the speed of the process it drives. Negative IR compensation may be used with both armature voltage and tachometer feedback regulated controls.

3.3.4 ARMATURE CURRENT ERROR AMPLIFIER

The armature current error amplifier compares an armature current reference signal (the output of the velocity error amplifier) with an armature current feedback signal (the output of the armature current scaling amplifier). The output of the armature current error amplifier is one of two reference signals applied to the phase angle reference circuitry.

3.3.5 PHASE ANGLE REFERENCE

The phase angle reference circuitry determines the correct SCR firing angle for the SCR power conversion assembly. Actual SCR firing is controlled by the SCR gating circuit.

3.3.6 CURRENT SENSING TRANSFORMER (CT1)

A current sensing transformer (CT1) measures the AC line current flowing in the power conversion assembly. The CT output waveform is rectified and normalized by the armature current scaling amplifier to provide a signal that is directly proportional to the current flowing in the DC motor. This signal is utilized as the feedback signal to the armature current error amplifier and it is also used as an input to the IR compensation circuitry.

3.3.7 ARMATURE VOLTAGE BUFFER/SCALING AMPLIFIER

The armature voltage buffer/scaling amplifier is used to isolate and scale the DC motor armature voltage for use by the phase angle reference circuit. The output of the armature voltage buffer/scaling amplifier is also used as "velocity" feedback in some applications.

The velocity error amplifier circuit is designed to function normally as a very high gain error amplifying circuit. It can also be configured to function as a low gain, input reference buffer amplifier. This configuration is normally used in current regulated drive applications. By jumpering Terminals #1 and #2 at the user terminal board (TB-1) and eliminating both the armature voltage and tachometer feedback signals, it is possible to reconfigure the ES-2700 to function as a current (torque) regulated DC drive control. When configured in this manner, the input reference signal applied to TB-1 Terminals #12 (or Terminal #4) will control DC motor current (torque) instead of DC motor speed.

Drive current limit is typically set using a potentiometer located on the ES-2700 control. In many applications, it is desirable to adjustable drive current limit using either a remote mounted potentiometer or a customer supplied voltage signal. A 0 to -12VDC signal applied to Terminal #15 (TB-1) adjusts drive current limit between 0 and 150% of the selected current range.

SECTION 4 INSTALLATION

4.1 SAFETY WARNINGS

Improper installation or operation of this control may cause injury to personnel or equipment. Read the operating instructions. The control and its associated motors and operator control devices must be installed and grounded in accordance with all local codes and the national electrical code. To reduce the potential for electric shock, disconnect all power sources before initiating any maintenance or repairs. Potentially lethal voltages exist within the control unit and connections. Use extreme caution during installation and start-up.

4.2 INITIAL CHECKS

Before installing the drive control, check the unit for physical damage sustained during shipment. Remove all shipping restraints and padding. Check nameplate data for conformance with the AC power source and motor.

4.3 DETERMINING THE CONTROL LOCATION

The ES-2700 is suitable for most well ventilated factory areas where industrial equipment is installed. Locations subject to steam vapors or excessive moisture, oil vapors, flammable vapors, chemical fumes, corrosive gases or liquids, excessive dirt, dust or lint should be avoided unless an appropriate enclosure has been supplied or a clean air supply is provided to the enclosure. The location should be dry and the ambient temperature should not exceed 40°C (104°F). If the mounting location is subject to vibration, the unit should be shock mounted.

If the enclosure is force ventilated, avoid, wherever possible, an environment having high foreign-matter content, as this requires frequent filter changes or the installation of micron filters. Should a control enclosure require cleaning on the inside a low-pressure vacuum cleaner is recommended. Do not use an air hose because of the possibility of oil vapor in the compressed air and the high air pressure.

4.4 INSTALLING CHASSIS MOUNT CONTROLS

The chassis mount ES-2700 is suitable for mounting in a user's enclosure where internal temperature will not exceed 55°C (131° F). The following instructions are recommended: Mount the chassis vertically against the mounting surface. Dimensions are shown in Figure 14. A minimum clearance of 3 inches around the ES-2700 is recommended for proper cooling when installing a chassis mount control.

CAUTION

NEVER OPERATE THE CONTROL FOR AN EXTENDED PERIOD OF TIME ON ITS BACK. DOING THIS WILL CAUSE THE HEAT FROM THE HEAT SINKS TO PENETRATE THE CONTROL LOGIC WIRING.

4.5 INSTALLING ENCLOSED CONTROLS

Enclosed ES-2700 controls are suitable for wall mounting in an ambient atmosphere between 0°C (32°F) and 40°C (104°F). Mount the control so that there is access to the front panel. See Figure 15 for dimensions. Never operate the control for an extended time on its back for the reason explained in section 4.4.

4.6 POWER WIRING

The ES-2700 control will operate from typical AC power lines. The line should be monitored with an oscilloscope to insure that transients do not exceed limitations as listed below:

- Repetitive line spikes of less than 10 microseconds must not exceed the following magnitude:
- 120 Volt Drives 200 V. Peak
- 240 Volt Drives 400 V. Peak
- Non-repetitive transients must not exceed 25-watt seconds of energy. Transients of excessive magnitude or time duration can damage dv/dt networks or surge suppressors.
- Line notches must not exceed 300 microseconds in duration.

An abnormal line condition can reflect itself as an intermittent power unit fault. High amplitude spikes or excessive notch conditions in the applied power could result in a power unit failure.

Refer to Figure 5 for power wiring connections. The ES-2700 is insensitive to the AC line phase sequencing. Designation of inputs L1 and L2 is arbitrary.

CAUTION

A SEPARATE FUSED DISCONNECT OR CIRCUIT BREAKER SHALL BE INSTALLED IN THE INCOMING AC POWER LINE TO THE CONTROL, AS PER THE NATIONAL ELECTRICAL CODE.

Use the AC line current specified on the nameplate of the control being installed to size the AC input wiring. Size the motor leads according to the motor nameplate current ratings following NEC requirements.

Connect the armature leads to the terminal lugs marked A+ and A- on contactor MC located above the upper right hand corner of the lower PC board. Consult the motor connection diagram supplied with the motor for proper polarity.

Check that the proper number of turns of the armature lead (from the SCR to the contactor) have been made around transducer CT1. The low (1/4-2) HP control should have 5 turns. The high (3-5) HP control should have 2 turns.

Connections to the motor field should be made with due consideration to the proper polarity. Consult the motor connection diagram. The ES-2700 field supply provides 100VDC when the control is wired to a 120VAC line and 200VDC when wired to a 240VAC line. The field supply provides 50VDC or 100VDC respectively when the field economy feature is wired in, AC power is applied to the control, and the loop contactor is open.

NOTE

The ES-2700 is shipped for the factory with the field economy feature wired for operation. It is recommended that this feature not be by-passed. It reduces the voltage to the motor field when the control is stopped but not removed from the AC input line. If the field economy feature is not used, then these terminals must be jumpered together.

All power connections (i.e., armature, line voltage) are made to the lower PC board through faston connections. In cases where polarity or phasing is critical, two different size fastons are used to insure proper polarity.

Verify that the input voltage and frequency select program jumpers A, B and L-M are correct for your application. The ES-2700 is shipped programmed for:

- 60Hz
- 240VAC
- High voltage armature feedback.

NOTE

A functional description of all jumpers is contained in Section 5, Operation and Startup Procedure. Check that all program jumpers are correct for you application.

CAUTION

NO POINTS IN THE CONTROL CIRCUITRY, INCLUDING COMMON, SHOULD BE CONNECTED TO EARTH GROUND UNLESS SPECIFICALLY SHOWN ON SYSTEM DIAGRAMS. CONNECT EARTH GROUND TO THE GROUND LUG BESIDE 3FU AND 4FU ON THE HEAT SINK CHASSIS ASSEMBLY.

WHEN READY TO APPLY POWER TO THE ES-2700, CONNECT THE 120VAC OR 240VAC SUPPLY LINES TO TERMINALS L1 AND L2 ON FUSE BLOCKS 3FU AND 4FU ON THE HEAT SINK/CHASSIS ASSEMBLY.

4.7 CONTROL LOGIC WIRING

Terminal strip TB-2 consists of two sections of terminal block. Terminals #1 through #15 are located along the left edge of the lower control board. Terminals #16 through #25 are along the bottom. Terminals #1 through #21 are used for control logic. See Table 6, Figure 6 and Figure 16 for terminal strip connections. A detailed description of control logic

functions is contained in SECTION 5. The wiring of the lower PC board is shown in Figure 20.

4.8 SIGNAL WIRING

Terminals #1 through #21 on terminal strip TB-1 are used for connection drive reference and feedback signals to the ES-2700. Terminals #1 through #15 are along the left edge. Terminals #16 through #21 are located along the bottom edge of the upper control board. See Table 6, Figure 6 and Figure 16 for terminal strip connections. The wiring of the upper PC board is shown in Figure 19.

NOTE

It is recommended that shielded wire be used for reference, tachometer, optional ammeter and other signal wire connections. Belden #83394 (2 conductor) and Belden #83395 (3 conductor) shielded wire (or equivalent) is recommended. The shields should be taped off at the remote end. At the drive control, the shields should be connected to common, TB-1 terminal 14. Additional consideration is recommended to route this wiring away from high current lines (i.e., AC line and armature wiring).

4.9 CIRCUIT BOARD INTERCONNECTIONS

There are six (6) multi-pin connectors used in the ES-2700 to supply power and transmit control signals for the upper and lower PC boards.

J1 is a 15 pin AMP connector that attaches to the upper right hand side of the lower PC board. It supplies power to the board from the AC inputs L1 and L2 and, in turn, feeds the primary of the control transformer. It also supplies AC power from the control transformer secondary to the DC power supplies and the 120VAC control logic. See Figure 5 for pin assignments.

CAUTION

CARE MUST BE TAKEN TO ALIGN THE PINS AND JACKS ON THE FOLLOWING MOLEX CONNECTORS TO AVOID WRONG CONNECTIONS AND DAMAGE TO THE CONTROL.

J2 is a 2 pin AMP connector located on the top edge of the lower PC board. The armature current feedback signal from transducer CT1 flows through J2.

J3 is a 15 pin Molex connector located in the center of the top edge of the lower PC board. It provides a quick means of connecting the optional test meter kit to the ES-2700. (The optional test meter kit will be discussed later in this section.) See Figure 16 for pin assignments.

J4 is a 16-pin ribbon connector that supplies $\pm 15\text{VDC}$ power, circuit common and the raw sync signal to the upper PC board. It is located on the back of the upper PC board in the top right hand corner. See Figure 16 for pin assignments.

J5 is a 16-pin ribbon connector located on the back of the upper PC board in the bottom right hand corner. It provides feedback and control signals from the lower PC board. See Figure 16 for pin assignment.

J6, located on the bottom right hand corner of the lower PC board, is a 2-pin AMP connector. It supplies the gate pulse signals from the firing circuitry to the SCR gates. See Figure 12.

4.10 INSTALLING MODIFICATIONS

4.10.1 TEST METER

The test meter kit, available for use in starting up and troubleshooting the ES-2700, screws down onto the upper PC board of the control. It is easily connected by installing the Molex connector, wired to the test meter PC board, into connector J3 on the lower PC board of the ES-2700.

This modification consists of a digital panel meter and multi-position selector switch. It provides the capacity to monitor nine critical drive parameters, including:

- Field Voltage
- Line Voltage
- Control Voltage
- Armature Voltage Armature Current (%)
- Current Limit (%) Trigger Signal
- Negative 15 VDC Reference
- Positive 15 VDC Reference

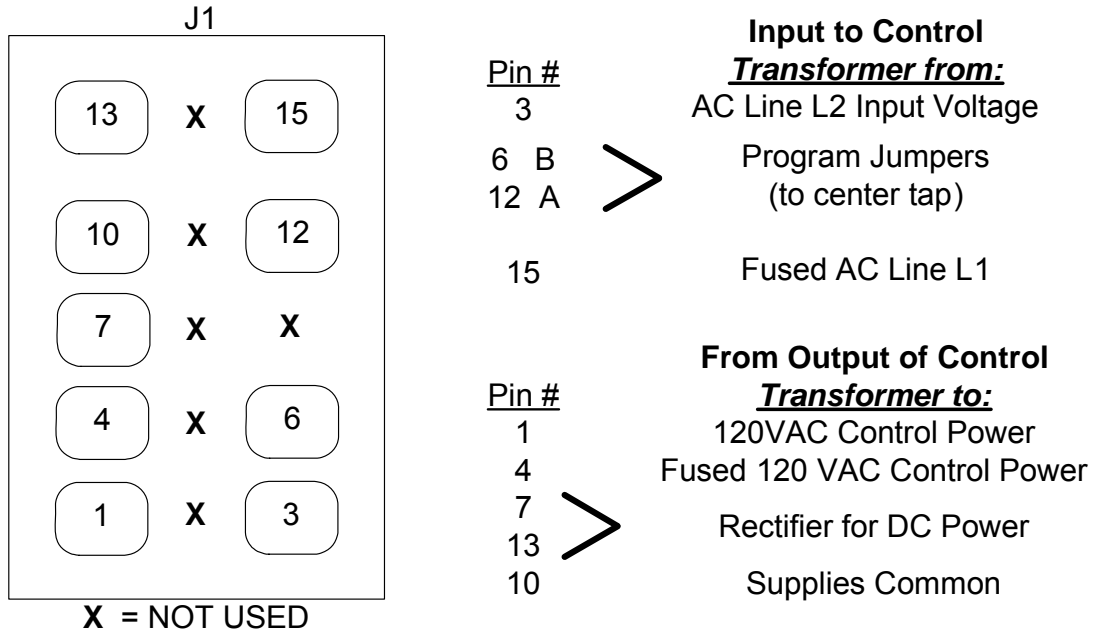
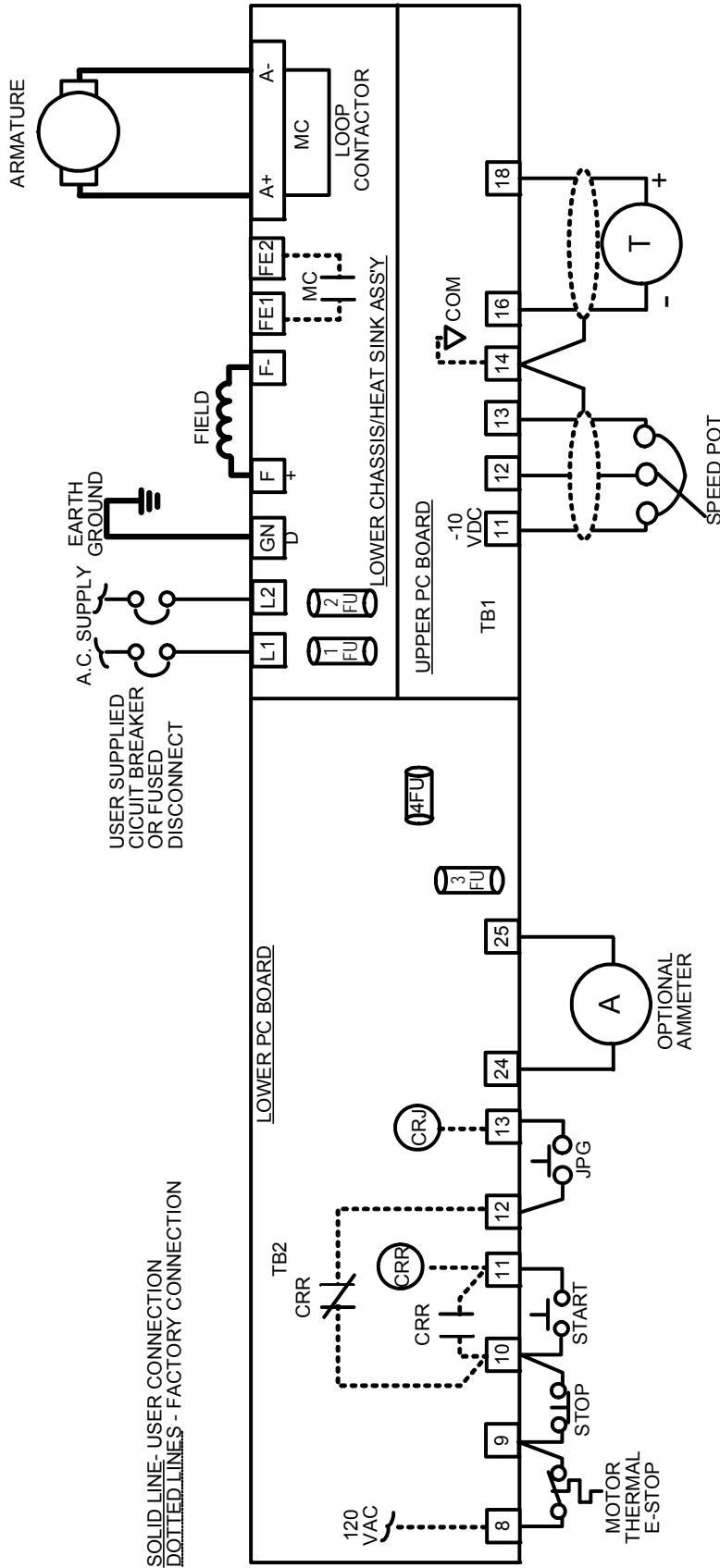

Figure 5: Connector J1 Pin Assignments



NOTICE: This drawing is furnished for reference only. The furnishing or possession of this drawing or any reproduction thereof, does not convey any manufacturing rights.

Melltronics Industrial, Inc. user connection diagram rotate.vsd
 REV. 03/02/2006

DRIVE CONTROL IS SUPPLIED, CONNECTED FOR ARMATURE VOLTAGE FEEDBACK, IF TACHOMETER FEEDBACK IS REQUIRED CONNECT THE TACHOMETER AS SHOWN AND SEE PARAGRAPH 5.4 FOR JUMPER REQUIREMENTS

Figure 6: User Connection Diagram

4.10.2 AMMETER KIT

The ES-2700 includes circuitry to drive an external ammeter without the addition of an ammeter shunt. This external meter can be calibrated in either percent load or in amperes. As shipped, the control has a minimum 100% current output rating of 6 amps. For applications below 1HP at 240VAC (1/2HP at 120VAC input), the built-in DC overload protection will be scaled for too much output current and will not function. To provide overload protection and properly calibrate the ammeter kit, removal of jumper N-O is required. The appropriate current range jumper settings are given in SECTION 5.

TB-2, terminals #24, located at the bottom of the lower PC board (see Figure 6), are for connecting the optional external ammeter. This meter should have a 0-100 μ A movement, 3700 Ω coil resistance and read 150% current full scale. A 200% full scale ammeter can be used when jumper JP-1 is removed from the lower PC board. A complete line of ammeters for the ES-2700 is available from Melltronics. Consult the web site, www.melltronics.com, and SECTION 5 of this manual for assistance in ordering a meter.

4.10.3 REMOTE CURRENT LIMIT

A potentiometer to modify the current limit setting of the ES-2700 from a remote location may be installed. The voltage signal from the wiper of the potentiometer is wired to TB-1 terminal 15. A -12V signal at that terminal yields 150% current limit. The -10VDC power supply, TB-1 terminal 11 and TB-1 terminal 14 (common) may be used to supply voltage for the remote current limit potentiometer. The equivalent resistance of the remote current limit potentiometer is parallel with the speed reference potentiometer, should not go below 5K Ω as this would excessively load the -10VDC power supply.

If remote current limit is used, remove jumper H-1 from the upper PC board and install jumper G-H. This is necessary to eliminate the local current limit potentiometer (on the upper PC board) from the circuit and provide a path for the remote current limit signal to enter the control.

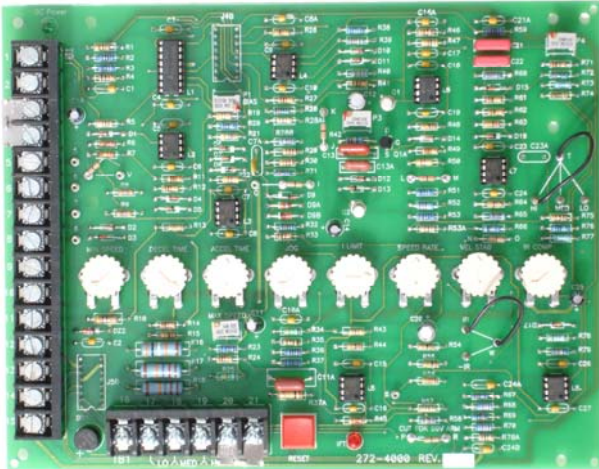

Figure 7: Upper PC Board

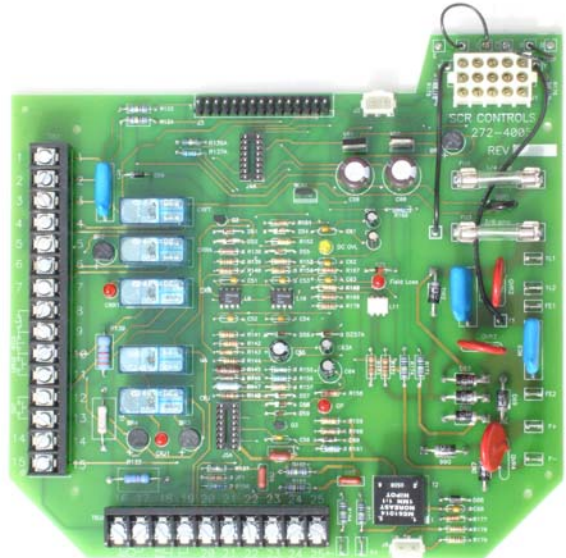

Figure 8: Lower PC Board

SECTION 5 OPERATION AND START-UP PROCEDURE

5.1 INTRODUCTION

This section describes the operator controls and their functions, initial start-up procedure, and applications adjustments of potentiometers and jumpers for the ES-2700.

Read this section thoroughly to develop an understanding of the operation and logic incorporated in the ES-2700.

5.2 OPERATOR CONTROLS

Refer to Figure 16, Figure 17, Figure 18 and Table 6 for operator control locations.

5.2.1 CONTROL VOLTAGE

Terminals TB-2#1 and #2 provide 120VAC control power for your use. A total of 5VA of power is available for user supplied devices.

5.2.2 FAULT TRIP RELAY (CRFT)

Under normal conditions, this relay is energized when AC power is applied to the ES-2700 control. When energized, CRFT enables the operator control devices by closing the contact that provides control voltage to these devices at terminal TB-2 #8.

There are three causes for a fault trip that drops out CRFT.

5.2.2.1 FIELD LOSS

The field loss circuit monitors the presence of field current. If field current is absent after the start pushbutton is depressed, the FL LED lights and CRFT drops out. The field loss LED may flash when AC power is first applied and the DC power supplies are coming up to their proper voltages. No fault trip will occur until the start pushbutton is depressed.

5.2.2.2 INSTANTANEOUS OVERCURRENT (IFT)

A fault trip occurs dropping out CRFT and lighting the IFT LED when an armature current, 300% of the rated current, is detected.

5.2.2.3 INVERSE TIME DC OVERLOAD (DCOL)

The DC overload circuit drops out CRFT and lights the yellow DCOL LED when the drive has run at 150% current limit for approximately one minute. Less severe overloading will take longer to trip out. See the inverse time trip characteristic in Figure 9.

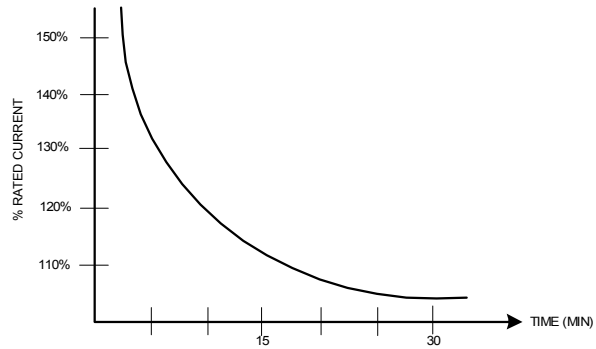

Figure 9: Inverse Time Trip Overload Characteristics

When a fault trip occurs and CRFT drops out, the control voltage to the operator devices is removed and the drive sequences down the same as if the STOP pushbutton were depressed. This sequence is given in the description of the STOP circuit.

The three causes of fault trips are sensed by latching type circuits and must be reset using the RESET pushbutton on the upper PC board.

A set of form C contacts off of CRFT is available to the user at TB-2 terminals #3, #4, and #5.

See Figure 16.

5.2.3 MOTOR THERMAL SWITCH/E-STOP

Motors with built-in fans may overheat when run for extended periods at low speed. A thermal sensing switch inside the motor will open before overheating occurs. When wired to terminals TB-2 #8 and #9, the open switch will stop the drive to protect the motor. A user supplied, normally closed switch may be wired in series with the thermal switch or in place of it to provide an E-stop function. If neither the thermal switch nor the E-stop is used, TB-2#8 and #9 must be jumpered. The shut-down sequence is the same as the stop function sequence.

5.2.4 STOP

When pressed, the STOP switch interrupts the path that supplies the current to keep the run relay (CRR) energized. This interruption results in the following reaction.

- The contact that locks in the relay (CRR) is opened,
- The contacts that permit the jog button to function are closed;
- The supply voltage that keeps the motor contactor energized is removed;
- The circuit from the speed potentiometer is open;
- The accel/decel, and velocity error and current error amplifiers are clamped.

5.2.5 START

When permitted by the fault trip relay (CRFT), the START switch momentarily closes the circuit that energizes relay CRR. When CRR is energized, contacts close that cause the following:

- CRR is locked on;
- A path is provided to energize the motor contactor;
- The reference voltage is connected from the speed pot to the accel/decel circuit;
- Controls that clamped the accel/decel, and velocity and current error amplifiers are opened;
- The jog switch that energizes the jog relay (CRJ) is disabled.

A set of normally open contacts off of CRR is available between terminals TB-2 #6 and #7. The RUN LED lights when CRR is energized.

5.2.6 JOG

When permitted by the run relay (CRR) and fault trip relay (CRFT), the JOG switch completes the circuit to energize the jog relay (CRJ). The jog relay then provides a path to energize the motor contactor and connect the jog reference signal to the jog circuitry. CRJ does not lock in so that when the jog pushbutton is released, the motor contactor drops out and the controller is in a stop condition. A set of N.O. contacts off of CRJ in parallel with N.O. contacts off of CRR is available to the user at terminals TB-2#14 and #15. The jog LED lights when CRJ is energized.

5.2.7 MOTOR CONTACTOR

The motor contactor is factory wired to terminals TB-2 #16 and #17. When energized, the contactor closes the DC loop that energizes the motor armature and the N.O. "A" auxiliary contacts disable the field economy circuit so that the motor receives full field voltage.

5.2.8 SPEED REFERENCE POTENTIOMETER

The signal from the speed reference potentiometer wiper is wired to Terminal TB-1 #12. A negative voltage reference signal corresponds to positive armature voltage. Negative 10VDC is available for the speed reference potentiometer at terminal TB-1 #11. The third lead of the speed reference potentiometer is connected to TB-1 terminal #13. This connection provides a voltage bias to the base of the speed reference potentiometer corresponding to minimum speed. This bias is adjusted using the MIN SPEED potentiometer on the upper PC board.

5.2.9 MISCELLANEOUS USER CONNECTIONS

- Terminal TB-1 #14 is control common
- Terminals TB-1 #5 through #8 are not for customer use.
- Terminal TB-1 #15 is the connection for the remote current limit signal covered in section 4.10.3.
- The field loss detection circuit is disabled when terminals TB 2 #20 and #21 are jumpered together. This is generally not recommended as severe motor and machine damage may result if overspeed occurs due to field loss.
- Operation as a current regulated drive using terminals TB-1 #1, #2 and #4 is covered in section 5.4.2.8 of this instruction manual. Tachometer feedback and the usage of terminals TB-1#16 through #21 is detailed in section 5.4.2.11 of this manual.
- Turret terminal 'S' on the upper PC board is an armature current signal for factory assembled customer applications and is not calibrated for customer use. A calibrated armature current signal is available at terminal strip TB-2 as explained in section 4.10.2.

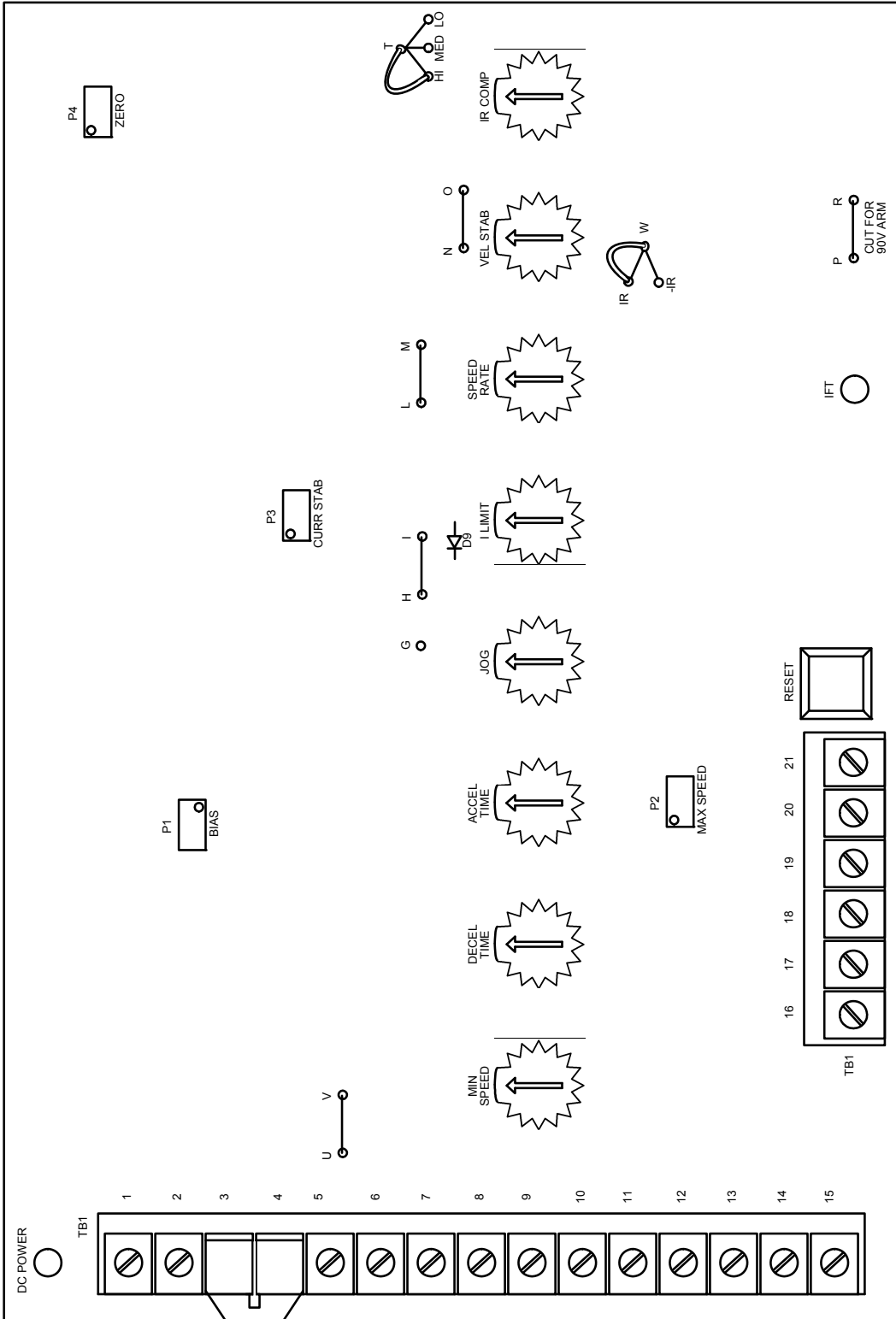

NOTICE: This drawing is furnished for reference only. The furnishing or possession of this drawing or any reproduction thereof, does not convey any manufacturing rights.

Melltronics Industrial, Inc. upper control bd oper feat rotate.vsd
REV. 03/02/2006

Figure 10: Upper Control Board Operating Features

5.3 ADJUSTMENTS

There are ten (10) adjustment potentiometers located on the upper control board (P/N 272-4000) Figure 10. Exercise caution when making adjustments. With the control driving a motor, do not exceed ten (10) degrees of pot rotation per second.

5.3.1 MIN SPEED

The MIN SPEED potentiometer adjusts the minimum speed of the drive according to the reference signal from the speed potentiometer. Minimum reference is from 0-30% of full rated speed.

5.3.2 DECEL TIME

The decel time potentiometer adjusts the amount of time the drive takes to decelerate. This rate of change of speed (ramp) is linear (constant) throughout the speed range but may be limited by the current limit setting. Set to mid-position by the factory, clockwise adjustment of this potentiometer causes the drive to ramp down in speed more slowly.

5.3.3 ACCEL TIME

The ACCEL TIME potentiometer adjusts the amount of time the drive takes to accelerate to the speed set by the speed reference potentiometer. This rate of change of speed (ramp) is linear (constant) throughout the speed range but may be limited by the current limit setting. Set to the mid-position by the factory, clockwise rotation of the ACCEL TIME potentiometer increases the time required to accelerate to set speed.

5.3.4 JOG

If a jog pushbutton is wired in, the jog potentiometer will adjust the speed at which the motor will run in jog. Jog speed may be set from 0 to 50% of maximum speed. Set fully counterclockwise by the factory, clockwise rotation of the jog potentiometer increases the jog speed.

5.3.5 I LIMIT (ARMATURE CURRENT LIMIT)

The I LIMIT potentiometer adjusts the maximum armature current that the control will supply to the motor. The range of adjustment is 0 to 150% of the rated current selected with jumpers T (LO, MED, HI) and N-O (Jumper T will be described later in this section). Clockwise rotation of this potentiometer increases the armature current.

5.3.6 SPEED RATE

When the drive experiences a step change in velocity, the velocity feedback signal lags behind this change. A "lead" compensation network is used to supply some additional feedback to compensate for the lag and reduce the rate of change in drive velocity. This also reduces the overshoot in the speed response of the drive. The amount of feedback compensation is proportional to the rate of

change of the feedback signal and is adjusted using the speed rate potentiometer. Clockwise rotation of this potentiometer causes a reduction in the rate of change of drive velocity and less overshoot. Normally used in tachometer feedback applications, the speed rate potentiometer is factory adjusted to its counterclockwise position.

5.3.7 VEL STAB (VELOCITY STABILITY)

This potentiometer adjusts the electrical "lead" of the compensating network in the velocity error circuit to correct for mechanical lags in the motor and driven system. Clockwise rotation causes the drive to respond more quickly to speed reference or speed feedback changes, but increases the 'overshoot' experienced by the drive. Counterclockwise adjustment of this potentiometer dampens the drive response. The factory shipped setting is at the 11 o'clock position.

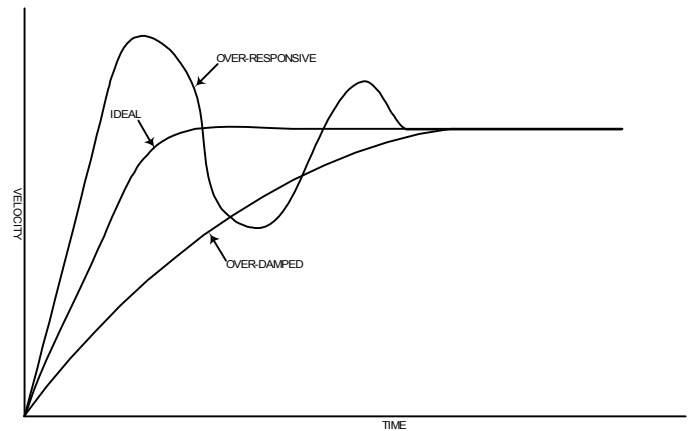

Figure 11: Stability Effects on the Velocity Profile

5.3.8 IR COMP (IR COMPENSATION)

The IR compensation circuit increases the drive speed reference signal as armature current increases. The effect of the increase in current is an increased voltage drop due to the impedance of the motor and also distortion of the field flux. The result is a reduction in counter emf produced by the motor and a reduction in speed, commonly called droop. Clockwise rotation of the IR comp potentiometer increases the amount of droop correction added to the speed reference signal. See section 5.4.2.7 for use of IR compensation.

5.3.9 MAX SPEED

When using armature voltage feedback, the max speed potentiometer scales the armature voltage feedback signal so that it exactly offsets a -10VDC reference signal when the motor reaches the desired maximum RPM. The speed reference potentiometer must be set for maximum (-10VDC) reference voltage, and the motor must be running at constant speed before adjusting the max speed potentiometer.

Determine the maximum motor speed required for your machine or process; do not exceed the rated speed of the motor. Using a tachometer or strobe light to measure the motor or the desired maximum speed is obtained. Clockwise rotation of this potentiometer increases the armature voltage and motor speed.

The range of adjustment is 70 to 130% of rated armature voltage.

For applications using tachometer feedback, the Max Speed potentiometer scales the tachometer feedback signal to offset the -10VDC reference signal at the chosen maximum motor speed. Calculate the tachometer output voltage corresponding to the desired maximum motor speed, and adjust the max Speed potentiometer until this voltage is read at the output of the tachometer.

5.3.10 CURR STAB (CURRENT STABILITY)

This potentiometer performs the same function in the current error circuit as the Vel Stab potentiometer performs in the velocity error circuit. However, since the current loop responds to current changes much faster than the velocity loop does to speed changes, the Cur Stab adjustment is much more sensitive and harder to adjust properly. Clockwise rotation increases response. The factory shipped setting of 4.5 turns from full counterclockwise is adequate for most applications.

5.4 JUMPER PROGRAMMING

The drive can be programmed for specific applications by programming the jumper configurations.

WARNING

EQUIPMENT DAMAGE AND/OR PERSONAL INJURY MAY RESULT IF ANY JUMPER PROGRAMMING IS ATTEMPTED WHILE THE ES-2700 IS OPERATIONAL. LOCK OUT POWER AT THE DISCONNECT BEFORE CHANGING ANY JUMPER POSITIONS.

5.4.1 LOWER PC BOARD

The locations of the lower printed circuit board jumpers are shown in Figure 12.

5.4.1.1 A/B LINE VOLTAGE SELECTORS

This pair of jumpers connects the incoming AC line to the control transformer and must be set to match the user supplied AC voltage.

For 120VAC input A to E
 B to D

For 240VAC Input: A to C
 B to CX

5.4.1.2 JP1 AMMETER SCALE SELECTOR

The optional ammeter, which is wired to TB-2, can be scaled to read 150% rated current full scale or 200% rated current full scale.

For 150% rated current full scale, install JP1.
For 200% rated current full scale, remove JP1.

5.4.2 UPPER PC BOARD

The locations of the upper PC board jumpers are shown in Figure 10.

5.4.2.1 CURRENT LIMIT JUMPERS G-I, H-I

If the current limit is being set by the internal current limit potentiometer, Jumper terminals H and I on the upper PC board should be left connected.

A potentiometer to modify the current limit setting of the ES-2700 from a remote location may be installed. In this case, jumper H-I should be removed and jumper should be connected across G-I.

The voltage signal from the wiper of the potentiometer is wired to TB-1 terminal #15. A -12V signal at the terminal yields 150% current limit.

The -10VDC power supply, TB-1 terminal #11 and TB-1 terminal #14 (common), may be used to supply voltage for the remote current limit potentiometer. The equivalent resistance of the remote current limit potentiometer in parallel with the speed reference potentiometer should not go below 5K ohms as this would excessively load the -10VDC power supply.

5.4.2.2 JUMPER J-K VOLTAGE ERROR AMPLIFIER

This jumper must be left in; it is for factory use in customized system applications.

5.4.2.3 JUMPER L-M FREQUENCY SELECTOR

The ES-2700 will operate on either 50Hz or 60Hz AC power.

5.4.2.4 JUMPER N-O LOW HP SELECTOR

This jumper is to be removed for very low HP (up to 1/3HP 120VAC; up to 3/4HP for 240VAC). Leave connected for higher HP.

5.4.2.5 JUMPER P-R ARMATURE VOLTAGE

Jumper P-R selects the armature voltage output for the ES-2700 control.

For 180VDC armature voltage, install jumper P-R.
For 90VDC armature voltage, remove P-R.

5.4.2.6 JUMPER T- (LO-MED-HI) CURRENT SELECTOR

This jumper selects the value of armature current that the drive will see as 100% rated current. The jumper selection sets the horsepower rating of the control by scaling the value of the armature current at which current limit will occur. Table 4 gives the jumper settings along with the 100% current values and subsequent horsepower ratings.

This ES-2700 control as shipped has a 100% current rating of 6 amps. For applications below 1HP at 240VAC input (1/2 HP at 120VAC input), the built-in DC overload protection will not be functional. For applications where overload protection is required or where the ammeter kit is used, remove jumper N-O.

To use the 150% ammeter scale, jumper JP1 on the lower PC board should be in. For a 200% full scale ammeter scale, remove JP1.

5.4.2.7 JUMPER W-(+IR, -IR) COMPENSATION SELECTOR

Jumper W- (+IR or -IR) selects either positive or negative IR compensation to be adjusted by the IR Comp potentiometer. Positive IR compensation was explained in section 5.3.8 as an increase in the speed reference when increasing armature current and speed droop occur. Negative IR compensation is useful when the ES-2700 is used in a follower or helper type application to keep the follower drive from taking too much load on itself or overrunning the lead drive. The IR Comp potentiometer reduces speed when it is turned clockwise and Jumper W is set for negative IR compensation.

5.4.2.8 JUMPER TB-1 #1 AND #2 CURRENT REGULATION

By jumpering terminals #1 and #2 at the user terminal board TB-1 and eliminating both the armature voltage and tachometer feedback signals, it is possible to reconfigure the ES-2700 to function as a current (torque) regulated DC drive control. When configured in this manner, the input reference signal applied to Terminals #12 will control DC motor current (torque) instead of DC motor speed. The accel/decel potentiometers will now control the rate of change of the torque reference. To eliminate the accel/decel potentiometer from this current regulator configuration, remove the jumper from TB-1 terminals #2 and #4 and connect the input reference signal to terminal TB-1 #4.

5.4.2.9 JUMPER U-V ACCEL/DECEL TIME REGULATOR

Accel/Decel time is adjustable from approximately 0.2 to 4 seconds when jumper U-V is connected, and accel/decel time is adjustable from approximately 2 to 30 seconds when this jumper is removed.

5.4.2.10 JUMPER TB-1 #3 AND #4

The output of the accel/decel circuit (TB-1, Terminal #3) is usually jumpered to the input of the velocity error amplifier (TB-1, Terminal #4).

5.4.2.11 JUMPERS FOR VELOCITY FEEDBACK TB-1, #17-18, #18-19, #19-20, #20-21

The velocity feedback signal may be an armature voltage feedback signal or it may be a signal from a motor mounted AC or DC tachometer. Terminals #16 through #21 (TB-1) are used to select the desired feedback signal and properly scale it for the application.

If armature voltage feedback is used, a jumper should be connected between Terminals #20 and #21 (TB-1). No other connections should be made to Terminals #16 through #21. When connected for armature voltage feedback, the 'Max Speed' potentiometer provides an adjustment range of gated armature voltage (90VDC or 180VDC plus or minus 30% assuming a -10VDC reference voltage). Standard ES-2700 controls are shipped from the factory programmed for armature voltage feedback.

Table 4: Armature Current Overload Scaling

Control	Horsepower		Input Amps @ Full Load	DC Armature Amps @ Full Load	T- (LO, MED,HI) Current Range Jumper	100% Current	Ammeter** Scale		Jumper N-O Status
	120VAC	240VAC					150%	200%	
272-8000	1/4	1/2	4.2	3.00	LOW	3A*	--	6A	Out
	1/3	--	5.6	3.00	LOW	4A*	6A	--	Out
	--	3/4	5.6	4.00	LOW	4A*	6A	--	Out
	1/2	1	8.5	6.00	LOW	6A	--	12A	In
	3/4	1 1/2	11	8.00	MED	8A	12A	--	In
	1	2	14	10.00	HI	10A	--	20A	In
272-8001	1 1/2	3	21	15.00	LOW	15A	--	30A	In
	2	--	28	20.00	MED	20A	30A	40A	In
	--	5	35	25.00	HI	25A	--	50A	In

*This ES-2700 control as shipped has 100% current rating of 6 amps. For applications below 1HP at 240VAC input (1/2 HP at 120VAC input), the built-in DC overload protection will not be functional. For applications where overload protection is required or where the ammeter kit is used, remove jumper N-O.

**To use the 150% ammeter scale, jumper JP1 on the lower PC board should be in. For a 200% full scale ammeter scale, remove JP1.

If DC tachometer feedback is used, the motor mounted DC tachometer should be connected between Terminals #16 and #18 on TB-1.

NOTE
Check that the polarity of the DC tachometer output voltage is correct for the chosen direction of motor rotation.

The armature voltage feedback jumper connected between terminals #20 and #21 must be removed and reinstalled as a tachometer feedback scaling jumper to two of the four feedback scaling terminals located on TB-1.

The placement of the tachometer feedback scaling jumper depends on the output voltage of the DC tachometer at maximum output voltages (at Max motor speed) that can be accommodated in each feedback range.

Feedback Range	Tachometer Voltage Output at Maximum Speed	Jumper Terminals
LOW	65VDC-130VDC	17 to 18
MED	94VDC-188VDC	18 to 19
HIGH	131VDC-262VDC	19 to 20

When connected for tachometer feedback the Max Speed potentiometer scales the tachometer feedback signal so that the tachometer feedback signal exactly offsets a -10VDC reference signal when the motor reaches the desired maximum RPM.

Provision has been made for the use of an AC tachometer connected to TB-1 Terminals #9 and #10. When using an AC tachometer, remove all jumpers or wire connections from TB-1 Terminals #17 through #21.

5.5 START-UP PROCEDURE

To insure maximum efficiency with a minimum amount of delay in production, factory start-up assistance by a factory engineer is available. Requests for factory start-up assistance should be made by contacting a Field Service Engineer prior to the required date.

NOTE
The following start-up instructions are intended only as a guide and should be clearly understood by the responsible installation personnel before proceeding.

5.5.1 POWER OFF CHECKS

- 1) Check that the motor armature, motor field, AC input power and operator devices are connected in accordance with these instructions and existing system diagrams. Check that the correct line fuses and power block are installed.
- 2) On the upper PC board, make the following jumper connections: (Jumpers were explained earlier in this section.)
 - a) W to IR
 - b) N-O according to Table 4.
 - c) Configuration of jumper L-M installed for 60Hz, removed for 50Hz operation.
 - d) Jumper H-I selected for internal current limit.
 - e) Configuration of jumper P-R set for proper armature voltage.
 - f) Proper selection of feedback range jumpers.
- 3) On the lower PC board, make the following checks and adjustments:
 - a) For 120VAC operation, A to E and B to D
 - b) For 240VAC operation, A to C and B to CX
- 4) Set the potentiometers on the upper PC board as follows:
 - a) Minimum Speed—Fully Counterclockwise
 - b) Decel Time—Fully Counterclockwise
 - c) Accel Time—Fully Counterclockwise
 - d) Jog Speed—Fully Counterclockwise
 - e) Current Limit—25% Clockwise
 - f) Speed Rate—Fully Clockwise
 - g) Velocity Stability—25% Clockwise
 - h) IR Comp—Fully Clockwise
 - i) Maximum Speed—Fully Counterclockwise
 - j) Current Stability—4.5 Turns from Full Counterclockwise Position (approximately 12K ohms factory supplied setting).
- 5) Make a detailed visual inspection of the system checking for:
 - a) Loose electrical connections.
 - b) Pinched wires at the control, motor or operator's station.
 - c) Loose mechanical connections, especially the tachometer coupling.
 - d) Mechanical binding.
 - e) Incorrect power transformer connections.
 - f) Metallic chips within the drive caused by drilling into the enclosure.
 - g) Incorrect jumper programming.

- 6) Using a VOM, measure the resistance between the following points. Disconnect test meter plug P3 from connector J3 if the optional test meter is installed.

(+) Test Lead	(-) Test Lead	Reading
L1	S2	Greater than 10 Ohm
L1	Chassis	infinite
L2	Chassis	infinite
L1	A+	Greater than 1 Meg
L1	A-	Greater than 1 Meg
L2	A+	Greater than 1 Meg
L2	A-	Greater than 1 Meg
L1	Signal Comm	Greater than 1 Meg
L2	Signal Comm	Greater than 1 Meg
A+	Signal Comm	Greater than 1 Meg
A-	Signal Comm	Greater than 1 Meg
A+*	Chassis	Greater than 1 Meg
A-*	Chassis	Greater than 1 Meg
F+	Chassis	Greater than 1 Meg
F-	Chassis	Greater than 1 Meg
A+	Chassis	Greater than 1 Meg
A-	Chassis	Greater than 1 Meg

*Refer to motor side of contactor.

NOTE: Signal Common is TB-1, terminal 14. A+ and A- connections, listed above, are on the drive side of the armature contactor.

5.5.2 POWER ON CHECKS

- Remove the 2-pin AMP connector P6 from the bottom edge of the lower PC board. These are the gate lead connections to the SCRs.
- Apply AC power.
- With a voltmeter, check the power supply voltages using the following table:

(+) Lead	(-) Lead	Reading
TB-2, #1	TB-2, #2	115VAC
TB-1, #11	TB-1, #14	-10VDC
J3-8	TB-1, #14	+15VDC
J3-7	TB-1, #14	-15VDC
TB-2, #22	TB-1, #14	+24VDC
TB-2, #23	TB-1, #14	-24VDC

- 4) If test meter is not connected, use a voltmeter to check the following voltages on test meter jack J3.

(+) Lead	(-) Lead	Reading	Parameter
Pin 12	Pin 9	0 VDC	Armature Volts
Pin 13	Pin 9	0 VDC	Armature Amps
Pin 15	Pin 9	± 0.1 VDC	Trigger Signal

- 5) Check the field voltage at terminals F+ and F-. With the field economy feature operational, you should read:

Approximately 100VDC for a 240VAC input
 Approximately 50VDC for a 120VAC input

- 6) Set the speed reference potentiometer to -10VDC. Note that the gate-firing indicator LED GP is now illuminated.
- 7) Depress the stop pushbutton. The gate-firing indicator is now dark.

5.5.3 DYNAMIC CHECKS

- Remove AC power. Connect the gate lead connector P6 to the lower PC board. Apply AC power.
- Set the current limit potentiometer to approximately 10% current (9 o'clock position).
- Set the speed reference potentiometer to -10VDC.
- Start the drive and slowly adjust the current limit potentiometer to the mid-position. When the motor no longer accelerates, adjust the maximum speed pot so that the voltage at the armature terminals is 180VDC for 240VAC input or 90VDC for a 120VAC input. See section 5.3.9 for adjusting Max Speed to suit your application.
- Adjust the velocity stability (Vel Stab) and speed rate potentiometers to achieve the desired motor response to speed changes. These adjustments were discussed previously in this section.

WARNING

THESE STABILITY ADJUSTMENTS MUST BE PERFORMED WITH CARE. MOTOR INSTABILITY WILL RESULT IF THESE POTENTIOMETERS ARE ADJUSTED TOO QUICKLY OR SET TOO HIGH. THESE POTENTIOMETERS SHOULD BE TURNED CLOCKWISE JUST ENOUGH TO PREVENT VELOCITY OVERSHOOT.

Adjust the current limit potentiometer for 100% current by turning it clockwise until 8VDC is measured at the anode of D9 located on the upper board. See Figure 10.

- 6) Check the accel/decel circuit for the 0.2-4 second range.
- Stop the drive and remove AC power.
 - Jumper pins U and V on the upper PC board.
 - Set the accel and decel potentiometers fully clockwise.
 - Apply AC power and start the drive. Note that the motor ramps to full speed in about 4 seconds.
 - Set each of the accel and decel potentiometers for the required ramping rate in the desired time range using the above procedure. Clockwise rotation of these potentiometers increases the ramp time.

- 7) Check the jog circuit.
 - a) Set the jog potentiometer fully clockwise.
 - b) While depressing the jog pushbutton, the armature voltage should read approximately 60VDC for a 180 VDC armature (30VDC for a 90VDC armature). Set the jog potentiometer for the desired jog speed.
- 8) Set the IR compensation. This adjustment is used only if armature feedback is used. (Set fully counterclockwise for tachometer feedback.)
 - a) Run the motor at maximum speed with no load.

- b) Record the motor RPM (hand tachometer required).
- c) Load the motor.
- d) Again measure the motor RPM. Match this 'loaded' speed to the unloaded speed of step '1' using the IR Comp potentiometer
- e) Repeat steps '1' through '4'.

WARNING
EXCESSIVE IR COMPENSATION CAN CAUSE THE DRIVE CONTROL TO BECOME UNSTABLE.

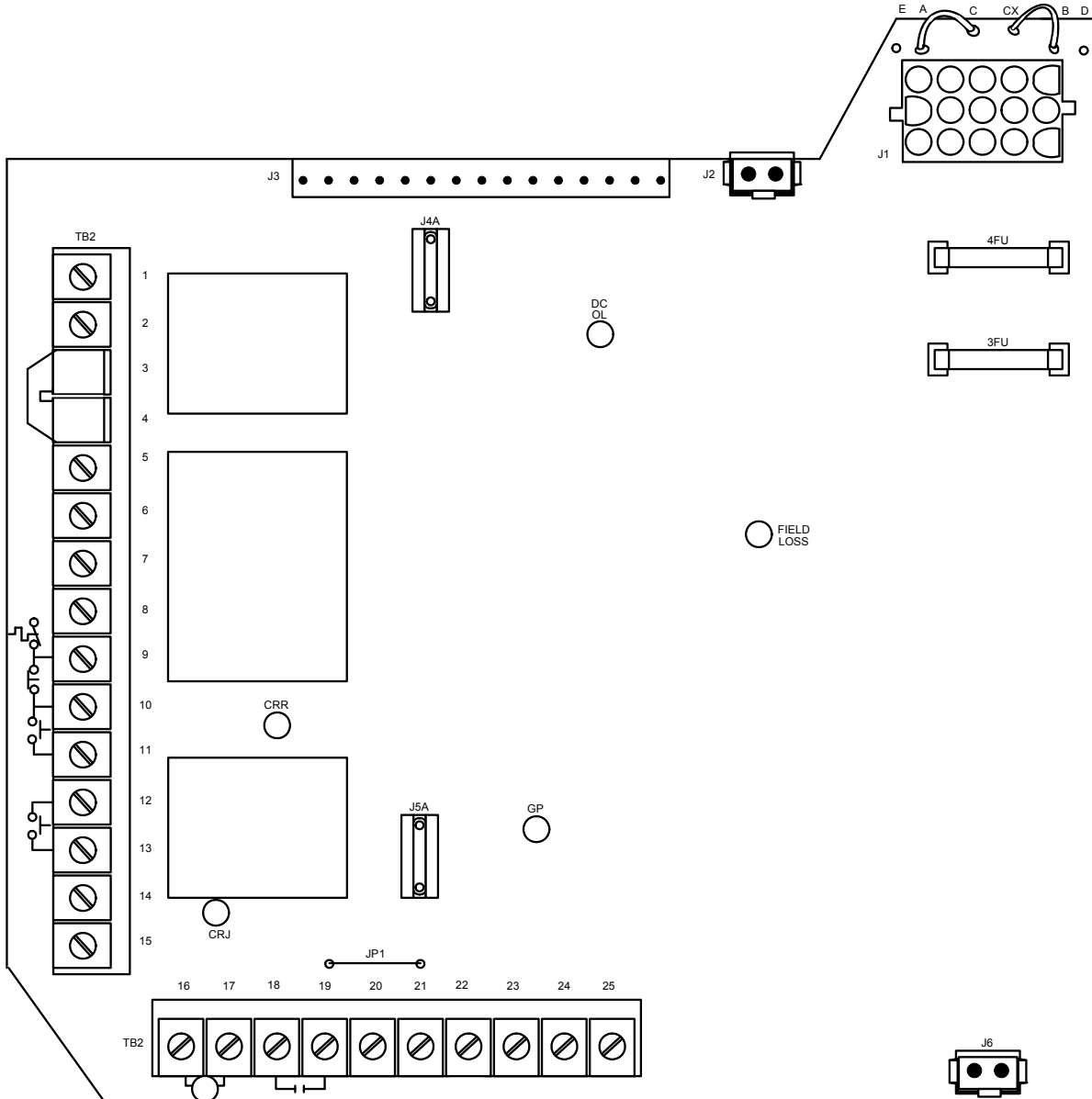

Figure 12: Lower PC Board Details

**SECTION 6
MAINTENANCE AND TROUBLESHOOTING**

6.1 IMPORTANT SAFEGUARDS

All maintenance work on the drive should be preformed by personnel familiar with it and its application. Before performing any maintenance or troubleshooting, read the instructions and consult the system diagrams.

WARNING

MAKE SURE THAT ALL POWER SOURCES HAVE BEEN DISCONNECTED PRIOR TO MAKING ANY CONNECTION OR TOUCHING INTERNAL PARTS. LETHAL VOLTAGES EXIST INSIDE THE CONTROL ANYTIME INPUT POWER IS APPLIED, EVEN IF THE DRIVE IS IN A STOP MODE. EXERCISE CAUTION WHEN MAKING ADJUSTMENTS. WITH THE CONTROL DRIVING A MOTOR, DO NOT EXCEED TEN (10) DEGREES OF POT ROTATION PER SECOND. NEVER INSTALL OR REMOVE THE CONTROL BOARD WITH POWER APPLIED TO THE CONTROL.

6.2 ROUTINE MAINTENANCE

Only minor adjustments should be necessary on initial startup, depending on the application. In addition, some common sense maintenance needs to be followed.

KEEP IT CLEAN: The control should be kept free of dust, dirt, oil, caustic atmosphere and excessive moisture.

KEEP IT COOL: The control should be located away from machines having a high ambient temperature. On chassis models, air flow across heatsinks must not be restricted by other equipment within the enclosure.

KEEP IT TIGHT: The equipment should be kept away from high vibration areas that could loosen connections or cause chafing of wires. All interconnections should be re-tightened at time of initial start-up and at least EVERY six months, thereafter.

WARNING

THE MOTOR MAY BE AT LINE VOLTAGE EVEN WHEN IT IS NOT IN OPERATION. THEREFORE, NEVER ATTEMPT TO INSPECT, TOUCH OR REMOVE ANY INTERNAL PART OF THE DC MOTOR (E.G. BRUSHES, ETC.) WITHOUT FIRST MAKING SURE THAT ALL AC POWER TO THE CONTROL AS WELL AS THE MOTOR HAS BEEN DISCONNECTED.

The motor should be inspected at regular intervals and the following checks must be made:

- 1) See that both the inside and outside of the motor is not excessively dirty. This can cause added motor heating and therefore can shorten motor life.
- 2) If a motor blower is used, make sure that the air passages are clean and the impeller is free to rotate. If air filters are used, they should be cleaned at regular intervals or replaced if they are

disposable. Any reduction in cooling air will increase motor heating.

- 3) Inspect the commutator and brushes. Replace the brushes if needed. Make sure that the proper brush grade is used and that you sand in the brushes to fit the commutator.
- 4) The motor bearing should be greased per the manufacturer's instructions as to type of grease and frequency. Over-greasing can cause excessive bearing heating and failure. Consult the instructions supplied with the motor for more details.

6.3 TROUBLESHOOTING

Fast and effective troubleshooting requires well-trained personnel supplied with the necessary test instruments as well as a sufficient stock of recommended spare parts. Capable electronic technicians who have received training in the controls operation and who are familiar with the application are well qualified to service this equipment.

6.3.1 SUGGESTED TRAINING

- 1) Study the system instruction manual and control drawings.
- 2) Obtain practical experience during the system installation and in future servicing.
- 3) Train in the use of test instruments.
- 4) Know assistance is available through the Technical Assistance Department at Melltronics Industrial.

6.3.2 MAINTENANCE RECORDS

It is strongly recommended that the user keep records of 'down-time', symptoms, results of various checks, meter readings, etc. Such records will often help service engineers locate the problem in the minimum time, should services be required.

6.3.3 GENERAL TROUBLESHOOTING

The most frequent causes of drive failure are:

- Interconnect wire discontinuity, caused by a broken wire or loose connection.
- Circuit grounding within the interconnections of the power wiring.
- Mechanical failure at the motor or tachometer.

DO NOT make adjustments or replace components before checking all wiring. Also, monitor all indicator lights before proceeding with troubleshooting checks, and check for blown fuses.

It should be noted that modern solid state electronic circuitry is highly reliable. Often problems which appear to be electrical are actually mechanical. It is advised that the motor be checked in the event of any drive problems. Refer to the motor owner's manual for maintenance and repair procedures.

6.3.4 NOTES FOR TROUBLESHOOTING TECHNICIAN

- 1) A minimum knowledge of system operation is required, but it is necessary to be able to read the system schematics and connection diagrams.
- 2) An oscilloscope (Tektronix 214 or equivalent) may be needed to locate problem areas and to make adjustments. However, the majority of problems can be solved by using a multi-meter and by parts substitution.

CAUTION

WHEN A TEST INSTRUMENT IS BEING USED, CARE MUST BE TAKEN TO INSURE THAT ITS CHASSIS IS NOT GROUNDED EITHER BY A GROUNDING PLUG CONNECTION OR BY ITS CASE BEING IN CONTACT WITH A GROUNDED SURFACE. EXTREME CARE MUST BE TAKEN WHEN USING THE OSCILLOSCOPE SINCE ITS CHASSIS WILL BE ELECTRICALLY 'HOT' TO GROUND WHEN CONNECTED TO THE CONTROL SYSTEM.

Multimeters having a sensitivity to 1,000 ohms per volt on DC (or more) are recommended.

NOTE

Do NOT use the ohm portion of a multimeter to check transistors, except where advised to do so in this manual. Also, never use a megger to check any portion of the control circuitry. Before troubleshooting the drive system, read the warning section and the notes on the use of test instruments.

6.3.5 USING THE TROUBLESHOOTING GUIDE

- 1) Refer to section 6.3.6 below and select the malfunction that most closely fits the observed condition of the drive
- 2) The number in parentheses indicates which section in 6.4 pertains to that specific problem. Proceed to the appropriate section.
- 3) Go through each section in 6.4 sequentially. Check to see if your drive is experiencing the symptom that is listed. If it is, perform the action given in the section, either correcting the symptom or referring to another subsection of 6.4. Otherwise proceed to the next symptom on the list.
- 4) If this troubleshooting guide does not indicate the source and solution of the specific problem, call Melltronics Industrial and request the Technical Service Department.

6.3.6 MALFUNCTION AS OBSERVED BY OPERATOR

- 1) Drive will not run at all. (6.4.1)
- 2) Drive runs to top speed. (6.4.2)
- 3) Drive is unstable. (6.4.3)
- 4) Drive is intermittent. (6.4.4)
- 5) Drive performance is unsatisfactory. (6.4.5)
- 6) Drive trips out. (6.4.6)
- 7) Motor will not reach top speed. (6.4.13)
- 8) Motor jumps upon starting. (6.4.14)
- 9) Various motor problems. (6.4.15 to 6.4.17)

6.4 CORRECTIVE ACTION FOR DRIVE MALFUNCTIONS

Refer to the appropriate section below (based on directions from section 6.3.6) to correct a drive malfunction.

6.4.1 DRIVE WILL NOT RUN AT ALL

- 1) No SCR module output
- 2) Motor Armature open-circuited. With all the power off, check for continuity in the armature circuit and for proper seating of the motor brushes.
- 3) Motor armature contactor does not pick up
- 4) Check that control is not in current limit. If it is, verify that there is motor field and motor armature is free to rotate and not binding excessively.

6.4.2 DRIVE RUNS TO TOP SPEED AT ALL SPEED POT SETTINGS.

- 1) If drive is armature voltage regulated, ensure that there is a jumper between terminals #20 and #21 on TB-1.
- 2) If drive is tach regulated, check for the presence of the tach signal and the proper polarity.
- 3) Check for a false reference signal to operational amplifier.
- 4) Check for loss of the -10VDC power supply.
- 5) Check to see if the reference pot is open.
- 6) IR Comp (if used) is set too high.
- 7) Shorted SCR(s).
- 8) 'Max Speed' pot is turned too far in the clockwise direction. Turn the 'Max Speed' pot fully counterclockwise and readjust the maximum drive speed per the startup instructions.

6.4.3 DRIVE IS UNSTABLE

- 1) If drive utilizes armature voltage feedback, insure that IR compensation has not been set too high.
- 2) If drive utilizes tachometer feedback, insure that the IR compensation pot is fully counterclockwise.
- 3) If the frequency of oscillation is a function of speed, this could indicate that there is a mechanical problem with the load.

- 4) If the frequency of oscillation is the same regardless of speed, Contact the Technical Service Department at Melltronics Industrial. For relatively small amplitude, fast oscillations, check tachometer coupling to the variable speed drive, gearbox backlash, timing belt oscillations, etc.
- 5) Check that the AC supply voltage is constant with load.
- 6) Check that the brushes are not worn, seated improperly, or sticking to the brush holders.

6.4.4 DRIVE IS INTERMITTENT

- 1) Keep an accurate log of the type of intermittent malfunction and the operating conditions at that time.
- 2) Monitor with the test instruments the circuits that are believed to be causing the problem, i.e. the reference circuit – if the drive intermittently slows down; the feedback circuit – if the drive intermittently speeds up, etc.
- 3) Check for loose connections, worn relay contacts, excessive environmental vibration of control panel, motor brushes, etc.

6.4.5 DRIVE PERFORMANCE UNSATISFACTORY

From knowledge of drive specifications and actual drive performance, refer deviations to Melltronics Industrial.

6.4.6 DRIVE TRIPS OUT

- 1) If 'IFT' light is on, refer to 6.4.9
- 2) If the IFT light is not on, refer to 6.4.8, and from a knowledge of the permissive circuitry involved, track down the cause of the trip-out.

6.4.7 NO SCR MODULE OUTPUT

- 1) No AC voltage input 6.4.12
- 2) Incomplete magnetic relay sequencing 6.4.8
- 3) Loss of reference 6.4.11

6.4.8 MAGNETIC SEQUENCING

Consult the description for operation for control relay sequencing and function.

6.4.9 'IFT' LIGHT IS ON

- 1) This is an indication of an excessive armature current which has shut the drive off. Depress the reset pushbutton momentarily and the 'IFT' light should extinguish.
- 2) By opening (and keeping open) the armature loop and actuating the magnetic sequencing, determine if the 'IFT' trip is due to electrical 'noise', refer to Melltronics Industrial.
- 3) If 'IFT' trips due to an actual over-current, check:
 - a) Balance wave-form.
 - b) Loss of the -10VDC power supply
 - c) DC short – shorted armature.
 - d) Rapid load change such as the application of a brake.

- e) Presence of SCR module voltage output before application to motor armature (if armature contactor is supplied).
- f) Current limit set too high, IFT too low.
- g) Check for proper number of turns to transducer CT1. (See section 4.6.)
- h) Check for transients on the AC line at the time of the IFT.
- i) Unbalanced Armature Wave-Form
- j) Contact the factory.

6.4.10 UNBALANCED ARMATURE WAVE-FORM

Contact the factory.

6.4.11 NO REFERENCE

- 1) Check for the loss of the -10 VDC power supply.
- 2) Check for reference volts at wiper of the speed pot.
- 3) Check that 'CRR' and 'CRJ' relays do pick up when run or jog is pressed respectively.

6.4.12 THE 'POWER' LIGHT IS EXTINGUISHED

Check the AC line fuses. If they are found to be bad, replace them with good fuses, but do not turn AC power on until the following checks have been made:

- 1) Check the condition of each of the power semiconductors using an ohmmeter. Make sure the polarity is correct. The 'plus' (+) lead will have the positive polarity from the battery in the multimeter. The SCR modules are tested as shown below. See section 6.5 for instructions on accessing the SCRs.
- 2) SCR TEST – Connect the positive lead from the ohmmeter to the anode of the SCR and the negative lead from the ohmmeter to the cathode of the SCR. The ohmmeter should read a value of resistance greater than 200,000 ohms.
 - a) Reverse the two ohmmeter leads and the resistance should read approximately the same (i.e., greater than 200,000 ohms.).
 - b) Connect the positive lead from the ohmmeter to the gate lead of the SCR and the negative lead to the cathode. The resistance should read less than 100 ohms but greater than 2 ohms.
 - c) Reverse the leads and the resistance should remain approximately the same.
 - d) Replace any defective SCRs, per section 6.5.
 - e) Turn on AC power after replacing fuses.
 - f) The 'AC power on' indicator should light.
 - g) Check line voltage.
 - h) Check control voltage. It should be 120 VAC +10% to -5%.
 - i) Make all other adjustments as described in the adjustment procedures.

6.4.13 MOTOR WILL NOT REACH TOP SPEED

- 1) Incorrect adjustment. (See section 5.3)
- 2) Low line voltage.
- 3) Motor is overloaded (i.e., control is in current limit).
- 4) Check that the motor brushes are not worn, seated improperly, or sticking to the brush holders.
- 5) Check for defective SCR(S).

6.4.14 MOTOR JUMPS UPON STARTING

Machine has high breakaway torque. Reduce if possible.

6.4.15 MOTOR OVERHEATS

- 1) Check that the motor is properly rated to run at that speed with load applied.
- 2) Is ambient temperature below 40°C. (104°F)
- 3) Motor ventilation restricted.
- 4) If supplied, check the blower motor rotation for proper direction.
- 5) Defective motor.

6.4.16 MOTOR NOISE EXCESSIVE

- 1) Loose motor mounting or load connecting coupling.
- 2) Damaged bearing.
- 3) Defective or maladjusted control.

6.4.17 MOTOR SPARKS EXCESSIVELY

- 1) Motor is overloaded.
- 2) Brushes are worn, or the wrong grade of brush is being used.
- 3) Rough commutator.
- 4) Defective or maladjusted control.
- 5) Brush rigging is improperly adjusted.
- 6) Commutating poles are not properly shimmed.

6.5 SCR REPLACEMENT.

(See Figure 13)

- 1) Remove and lockout AC power to the control.
- 2) Label and remove all leads connected to AC1 and AC2 of the SCR

NOTE

Power block uses metric (10mm) screw terminals.

When testing, remove the gate leads (G1 or G2) one at a time, perform the test and replace the gate leads to avoid connection errors.

- 3) To replace the SCR power block:

- a) Remove the 2 hold down bolts and remove the power block.
- b) Sparingly apply silicon thermal compound to the bottom of the new power block.
- c) Bolt the new power block in place. Torque the hold down bolts to 19 inch-pounds.
- d) Transfer electrical connections from the used power block to the new power block one at a time to avoid connection errors.

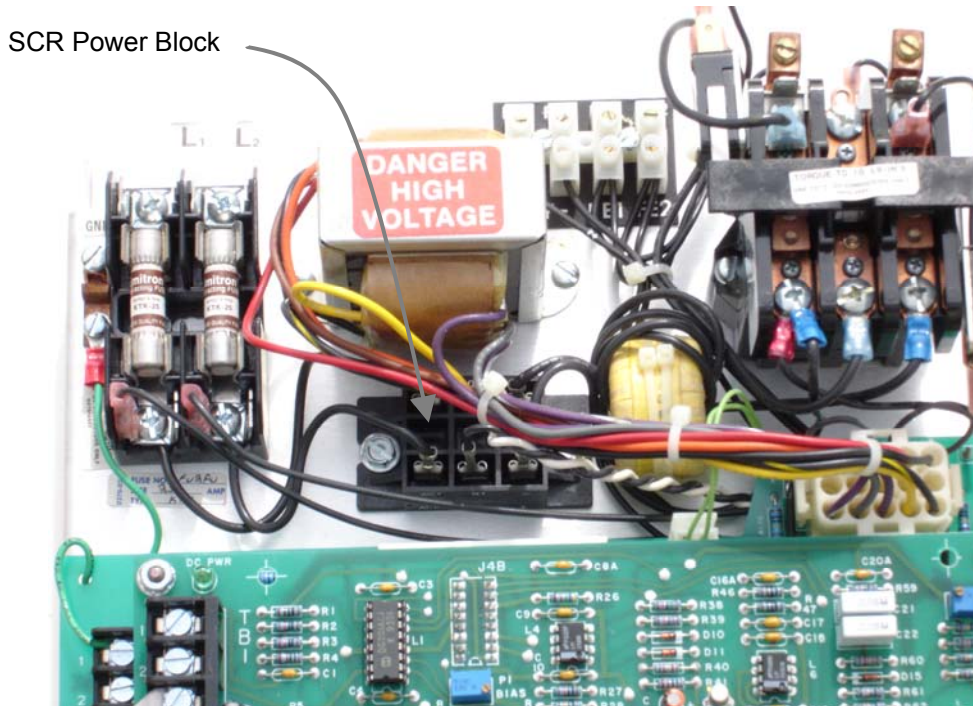

Figure 13: SCR Location

**SECTION 7
ORDERING SPARE PARTS**

Table 5:
Recommended Spare Parts for the ES-2700

LINE FUSES (QTY 2)

Control	Rating	Part Number
272-8000	25A.600V	3707-602500
272-8001	50A, 500V	3401-505000

CONTROL POWER FUSES (ALL MODELS)*

Designation	Rating	Type	Part Number
3FU	3/8A, 250V	3AG	3704-124
4FU	1/4A, 250V	3AG	3704-120

POWER BLOCK (QTY1)

Control	Rating	Part Number
272-8000	25A.600V	3720-004
272-8001	50A, 500V	3720-010A

MAIN (REGULATOR) PC BOARD (ALL MODELS)

Part Number 272-4000

FIRING PC BOARD (ALL MODELS)

Part Number 272-4005

*Included on Main PC Board

SECTION 8
SUPPLEMENTARY TECHNICAL INFORMATION

Outline and Mounting Dimensions for Chassis Mount and Enclosed ES-2700 Controls

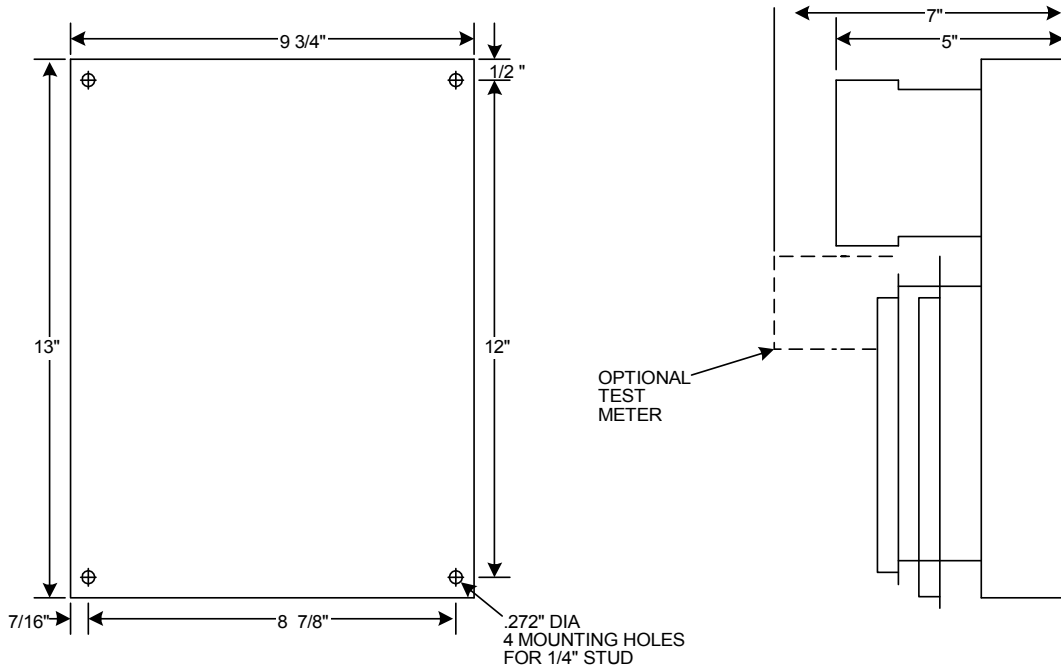

Figure 14: Chassis Mount Control

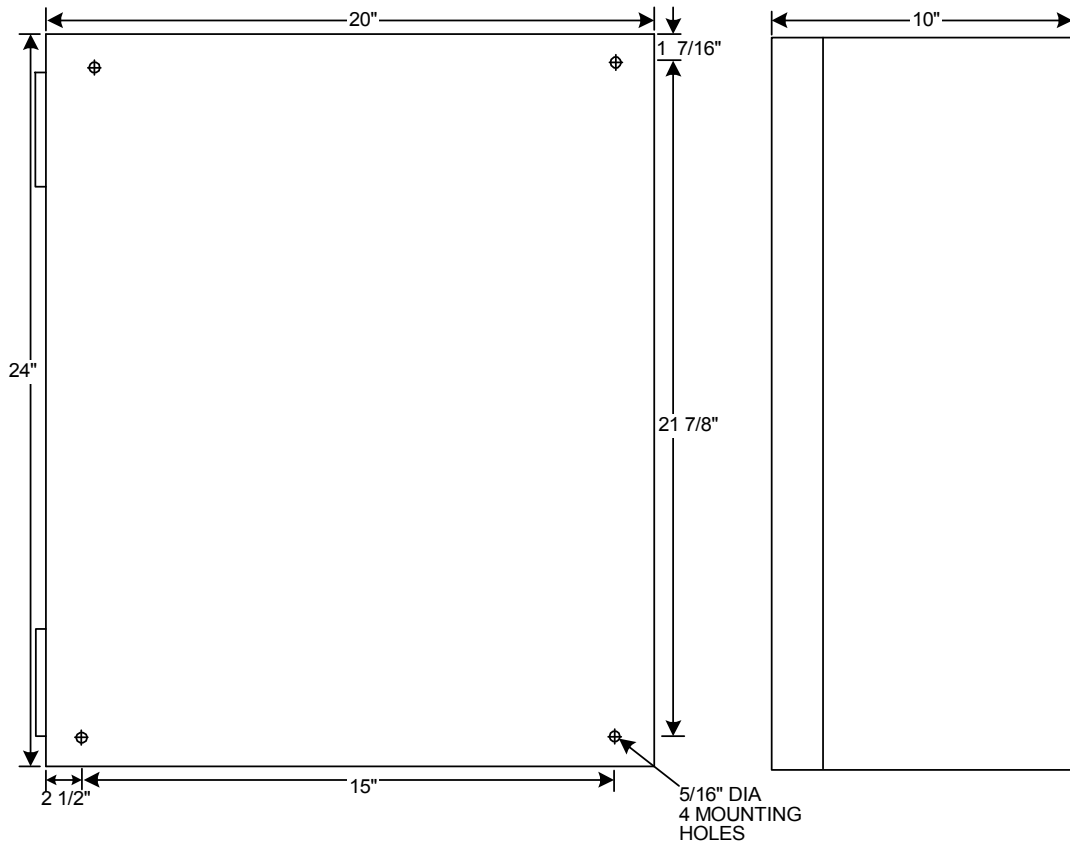

Figure 15: Enclosed Control

Table 6: Terminal Strip Connections

TB-1 Signal Terminals	TB-2 Control Logic Terminals
1. Jumper for Current Regulator	1. 120 VAC Control Power (5VA Max)
2. Jumper for Current Regulator (8V - 100% Current)	2. 120VAC Control Power (5VA Max) Fuse Side
3. Output Accel/Decel Circuit	3. N.O.
4. Input to Velocity Error Amp	4. Form C Fault Trip Relay Contact (Arm)
5. Turret Terminal for Drive Modification	5. N.C.
6. Turret Terminal for Drive Modification	6. Run Contact N.O.
7. Turret Terminal for Drive Modification	7. Run Contact N.O.
8. Turret Terminal for Drive Modification	8. 120VAC Switched through IFT Contact for Operator Devices
9. AC/DC Tach Connection	9. Motor Thermal Connection/ESop
10. AC/DC Tach Connection	10. N.C. Stop Pushbutton
11. -10 VDC for Reference Input Only	11. N.O. Run Pushbutton
12. Reference Input (through Accel/Decel)	12. N.O. Jog Pushbutton
13. MIN SPEED potentiometer setting	13. N.O. Jog Pushbutton
14. Common	14. 120VAC Switched through IFT Run/Jog Contact
15. Remote Current Limit Phase to -12VDC (0-150%) 22K Input	15. 120VAC Switched through IFT Run/Jog Contact
16. Tach Input (-)	16. M Contactor (100VDC)
17. Low Tach Voltage Selection	17. M Contactor (100VDC)
18. Tach Input (+)	18. M Contactor Aux
19. MED Tach Voltage Selection	19. M Contactor Aux
20. HIGH Tach Voltage Selection	20. Field Loss Defeat
21. Output armature voltage isolator Amplifier 6Volts = Rated Voltage (Pos for Pos Arm)	21. Field Loss Defeat
	22. +24VDC
	23. -24VDC
	24. Optional Ammeter Connection
	25. Optional Ammeter Connection

Table 7: Jumper Programming Quick Guide

The following chart summarizes the various jumper functions on the printed circuit boards as well as at the terminal strips. Amp pins 5, 6, 7, and 8 are connected to pins 5, 6, 7 and 8 respectively, at TB-1 for system design applications. Except for the power supply input jumpers and the field loss defeat jumper, all jumpers are located on the top board (272-4000). Test pin S is provided for looking at the current feedback.

Jumper (s)	Functional Description
A-C, B-C	Program power supply transformer for 230VAC input
A-E, B-D	Program power supply transformer for 115VAC input.
TB2, 20-21	Defeat field loss circuit
G-I	External current limit at TB1, pin 15.
H-I	Internal current limit.
J-K	Connect velocity error amplifier to current error amplifier.
L-M	Jumper for 60Hz operation. Remove for 50Hz operation.
N-O	Remove for very low horsepower.
P-R	Jumper for 180V armature. Remove for 90V armature.
T-LO	Low current feedback range, 6/15 amps (1/4-2HP/3-5HP)
T-MED	Medium current feedback range, 8/20amps (1/4-2HP/3-5HP)
T-HI	High current feedback range, 10/25 amps (1/4-2HP/3-5HP)
W-IR	Increase motor speed under load.
W to -IR	Reduce motor speed under load.
TB-1, 1-2	Jumper for current regulation.
TB-1, 3-4	Connect accel/decel circuit to velocity error amplifier.
TB-1, 2-3, 3-4	Reduce input resistance to velocity error amplifier to 5K ohm.
TB-1, 17-18	Low tachometer feedback range, 65 to 130V.
TB-1, 18-19	Medium tachometer feedback range, 94 to 188V.
TB-2, 19-20	High tachometer feedback range, 131 to 262V.
U-V	Add jumper for 1/4 to 4 second accel/decel time, 2 to 30 second accel/decel time without jumper.

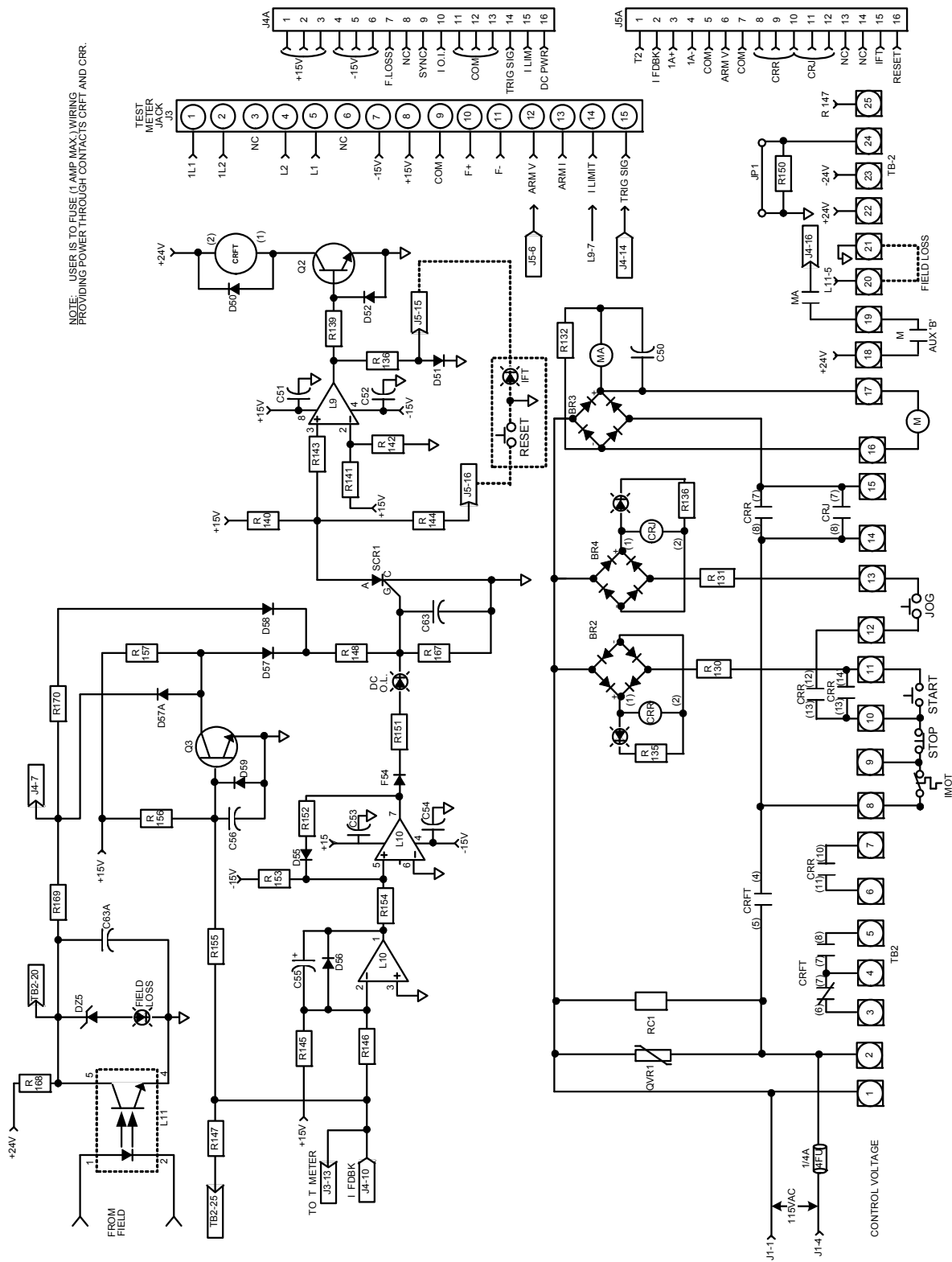

NOTE: USER IS TO FUSE (1 AMP MAX.) WIRING PROVIDING POWER THROUGH CONTACTS CRFT AND CRR.

NOTE: This drawing is furnished for reference only. The furnishing or possession of this drawing or any reproduction thereof, does not convey any manufacturing rights.

Figure 16: Control Logic and Test Meter Connections

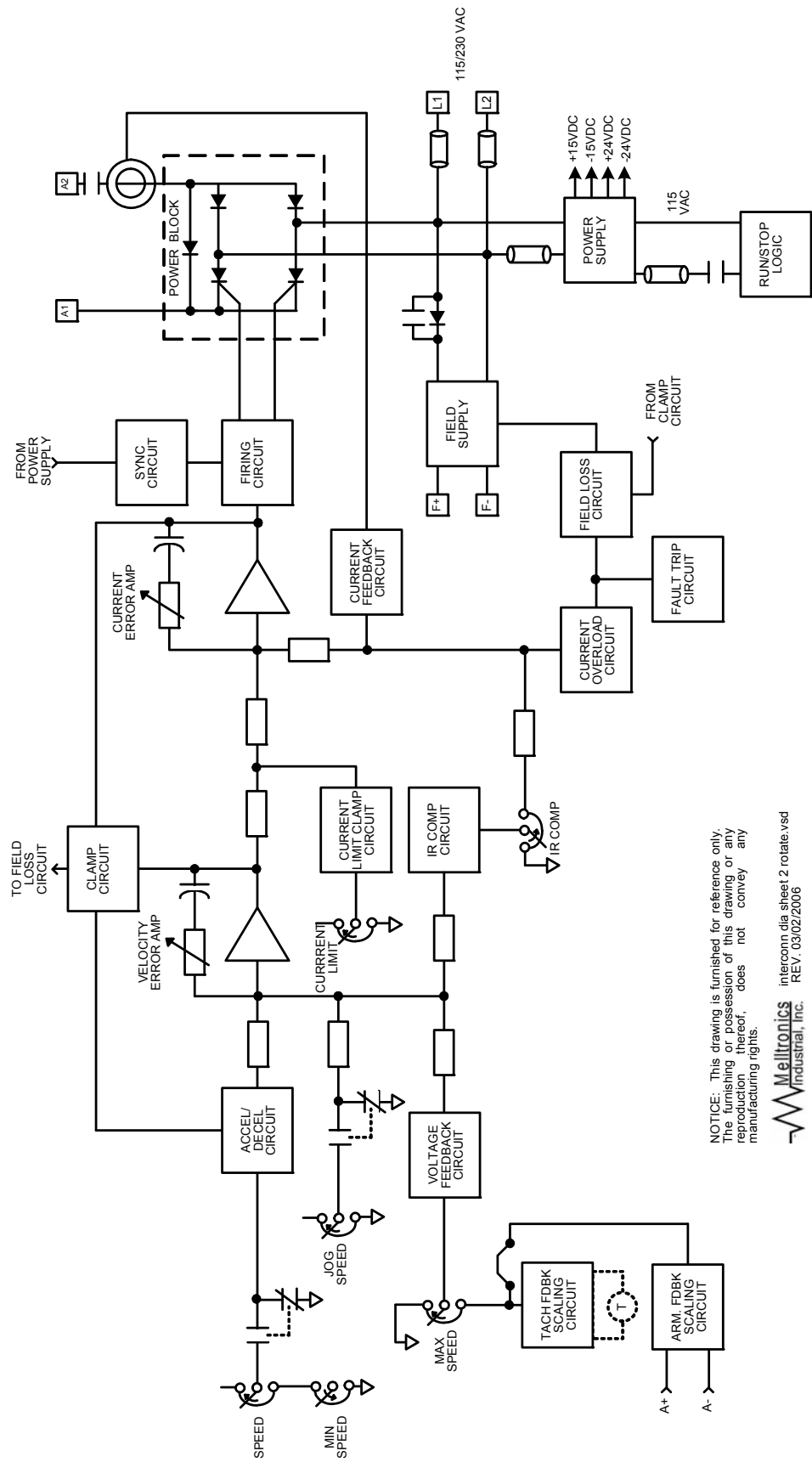

NOTICE: This drawing is furnished for reference only. The furnishing or possession of this drawing or any reproduction thereof, does not convey any manufacturing rights.

Melltronics
interconn dia sheet 2 rotate.vsd
REV. 03/02/2006

Figure 18: Interconnect Diagram 272-1000-I, Sheet 2

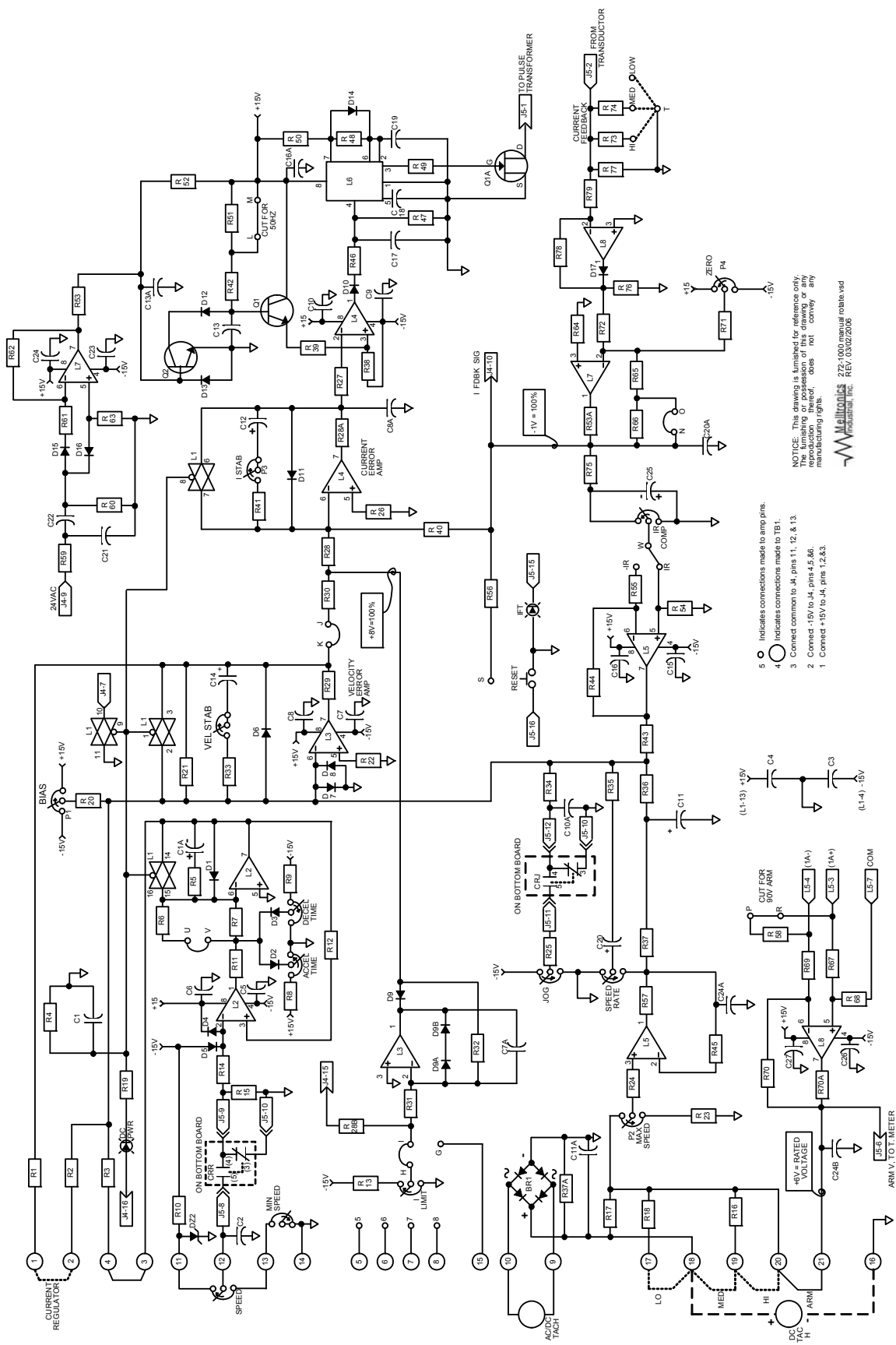

NOTICE: This drawing is furnished for reference only. The furnishing or possession of this drawing or any part hereof does not constitute any warranty, express or implied, by the manufacturer.

272-1000 original name.vsd
 Milltronics
 REV. 10/20/88

- 5 ○ Indicates connections made to amp pins.
- 4 ○ Indicates connections made to TB1.
- 3 Connected common to J4, pins 11, 12, & 13.
- 2 Connected -15V to J4, pins 4, 5, & 6.
- 1 Connected +15V to J4, pins 1, 2, & 3.

Figure 19: Top PC Board Schematic - Diagram 272-1000

REVISION TABLE

REV	DATE	DESCRIPTION	REVISIONS
NONE	04/03/2006	1 ST RELEASE BY MELLTRONICS	NONE

SECTION 9 WARRANTY

MELLTRONICS warrants to the Buyer whom purchases for use and not for resale that the equipment described in this instruction manual is sold in accordance with published specifications or the specifications agreed to in writing at the time of sale. Melltronics further warrants that such goods are free of defects in material and workmanship.

The warranty shall apply for a period of twelve months (12) from date of purchase, not to exceed eighteen months (18) from the date of manufacture.

If the goods fail to perform to Melltronics specifications as outlined in the warranty, then Buyer should contact Melltronics to obtain a "Material Return Authorization" (MRA), prepare the goods for shipment and return the goods to Melltronics for repair or replacement at Melltronics option. Buyer will bear all costs of transportation to and from Melltronics factory, risk of loss for goods not at Melltronics factory and any cost required to remove or prepare the goods for shipment to the repair facility, and to reinstall equipment subsequent to repair.

This warranty is effective only if written notification of any claim under this warranty is received by Melltronics at the address indicated below within thirty-days (30) from recognition of defect by Buyer.

The above indicates the full extent of Melltronics liability under this warranty. Melltronics specifically disclaims any liability for: (a) damage or failure due to improper use or installation; (b) damages in shipment; (c) damage or failure due to abnormal operation conditions of load, temperature, altitude or atmosphere whether intentional or unintentional; (d) non-authorized service, repair, modification, inspection, removal, transportation or installation; (e) misapplication or misuse, or; (f) consequential damages arising out of the use, operation or maintenance of the goods.

THERE ARE NO OTHER WARRANTIES, EXPRESSED OR IMPLIED, WHICH EXTEND BEYOND THAT DESCRIBED HEREIN. MELLTRONICS SPECIFICALLY DISCLAIMS ANY IMPLIED WARRANTY OF MERCHANTABILITY OF GOODS OR OF THE FITNESS OF THE GOODS FOR ANY PURPOSE.

Melltronics neither assumes nor authorizes any representative or any other person to assume for Melltronics any other liability in connection with the sale or any shipment of Melltronics goods. Melltronics reserves the right to make changes and improvements in Melltronics goods without incurring any obligation to similarly alter goods previously purchased.



MAIL: PO BOX 2368
INDIAN TRAIL, NC 28079-2368
SHIPPING: 3479 GRIBBLE ROAD
MATTHEWS, NC 28104-8114

PHONE: 704-821-6651
www.melltronics.com