

ABB DCS800 DC Drive

DCS800 20 A to 5200 A
Technical catalogue



ABB

Type code



Type code:

DCS800 - **S01** - **0680** - **04** - **+ B055**

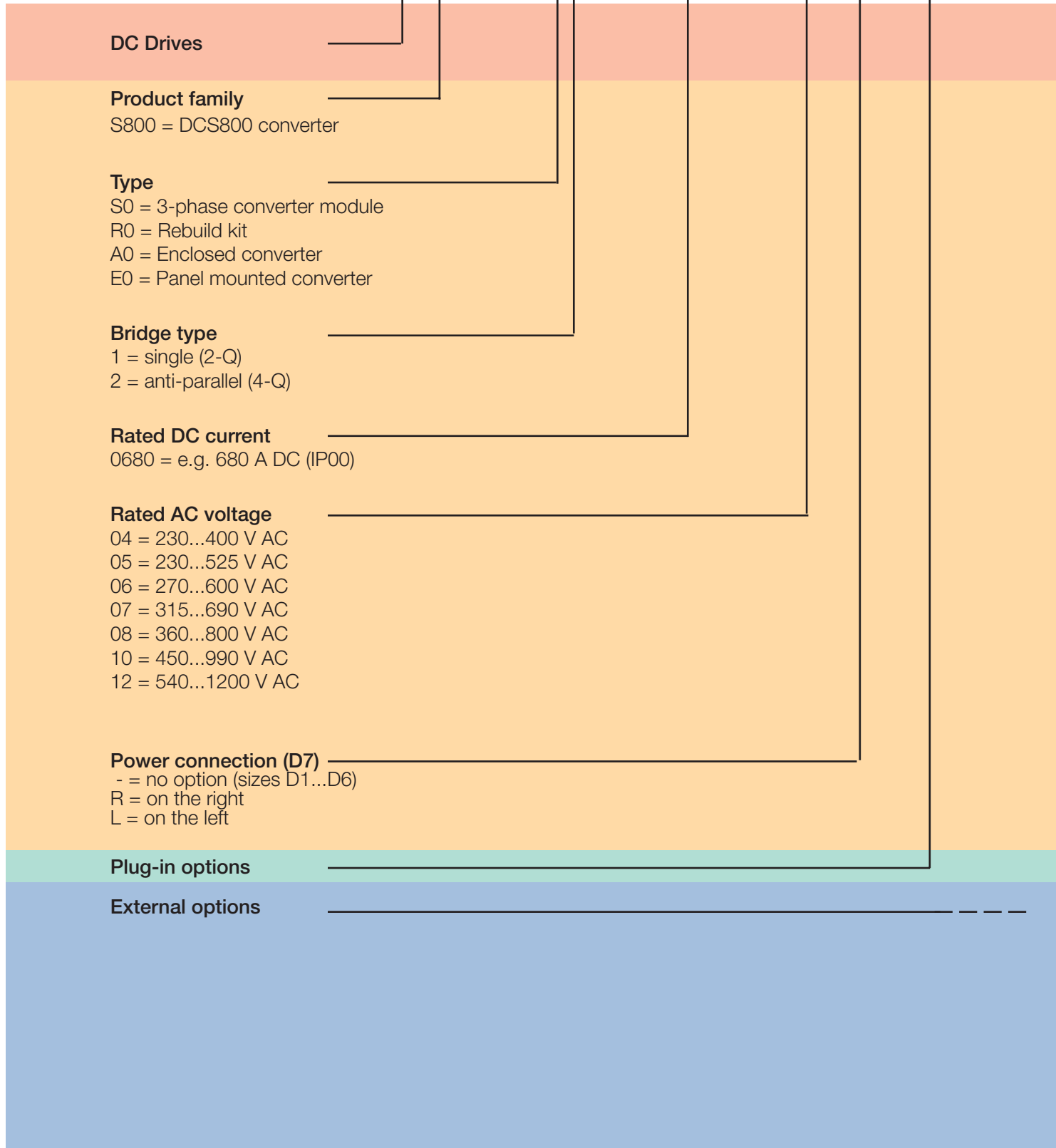

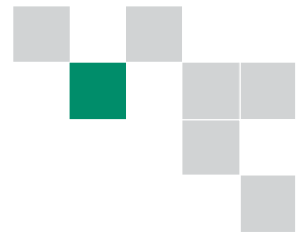

Contents

ABB DCS800 DC Drive

	Page
ABB DCS800 DC Drive.....	4
DCS800 Power Converter Modules.....	5
Ratings, types and voltages	6
Current ratings.....	7
Environmental conditions	8
Dimensioning.....	11
Easy commissioning	12
Startup Assistant	13
DCS800 Firmware.....	14
Plug-in options	15
External field supply.....	16
Fuse connections	18
Line reactors.....	19
IEC 61131 programming	20
Fieldbus control.....	21
DriveWindow Light 2.....	22
Startup, maintenance and integration (DriveWindow 2).....	24
Startup, maintenance and integration (DriveOPC)	25
Remote monitoring tool	26
Service products	27

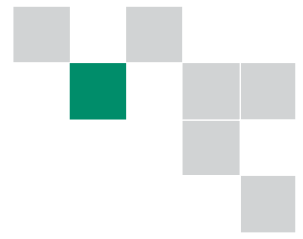

What is an DCS800 DC Drive?

The DCS800 DC Drive is simple to buy, install, configure and use, saving considerable time.

- Precise delivery
- Quick installation
- Rapid startup

The drive has common user and process interface with fieldbus, common software tools for sizing, commissioning, maintenance and common spare parts.

Where can it be used?

DCS800 can be used in the wide range of all industrial application of

- Metals
- Pulp & Paper
- Material handling
- Test rigs
- Food & Beverage
- Printing
- Plastic & Rubber
- Vessels
- Ski lifts
- Magnets
- Mining
- Electrolysis
- Battery Chargers
- and more

DCS800 DC Drive promises

The drive meet the requirement of all demanding drive application like: • testrig • mine hoist • rolling mill as well as none motoric applications like: electrolysis • magnetics • battery charger ...

Embedded software functions offer the upgrades of all classic installations 12-pulse, shared motion, double motor operation, field reversal control.

Highlights

- Assistant control panel providing intuitive use of the drive.
- Excellent control performance up to highest dynamic application in field weakening operation.
- All ACS800 PC tools (via DDCS) can be connected
- Reduced installation and commissioning work.
- Internal three phase field exciter without additional external hardware.
- Prepared for additional software function by adaptive programming and IEC1131 programming.
- Flexible fieldbus system with built-in Modbus and numerous internally mountable fieldbus adapters.

What are its main features?

Feature	Note	Benefit
Assistant control panel	Two soft-keys, function of which changes according to the state of the panel Built-in "Help" button Real-time clock, allows timed tracing of faults Changed parameters menu	Easy commissioning Fast set-up Easier configuration; Rapid fault diagnosis Quick access to recent parameter changes
Startup assistant	Available in DriveWindow Light tool and DCS800 Panel	Guided commissioning Preselected important parameter Help function Reduced commissioning time
Several Autotunings	Speed-, armature current, field current control and field weakening	Reduced commissioning time Reduced training
Connectivity	Simple to install: Easy connection of cables Easy connection to external fieldbus systems through multiple I/Os and plug-in options	Reduced installation time Secure cable connections
Diagnostic assistant	Activated when fault occurs	Quick fault diagnostics, short commissioning
Advanced DC operation	12-pulse parallel, 12-pulse serial, sequential control and sandwich configuration	Drive fit to all classic and advanced installation up to highest power
Advanced motor control	Motor voltage controller takes care on line voltage level and sudden voltage drop	Reliable and safe operation also for weak networks
Fieldbus	Built-in Modbus using RS 485 Optional plug-in fieldbus modules	Reduced cost
Highest motor voltage	By reduced dynamic the motor voltage can be increased	Simple upgrading of original 2-Quadrant installations to 4-Quadrant operation
ACS800 interfaces	All HW options and PC tools of ACS800 are available with same plus code	Reduced spare parts Reduced training Simple ordering

DCS800 Power Converter Modules

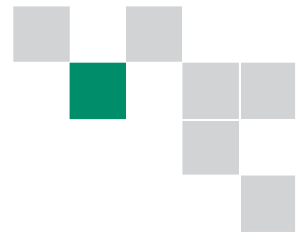

General

The power converter modules DCS800-S0x have the protection class IP00 and are to be mounted in a cubicle or finger protected area. There are different sizes (D1, D2, D3, D4, D5, D6, D7), graduated in terms of current and voltage ranges.

All units are equipped with control panel DCS 800PAN. It can be snapped into place on the power converter module or installed in the switchgear cubicle door by means of a mounting kit.

Accessories such as external fuses, line reactors etc. are also available, to compose a complete drive system.

All converter modules up to 525 V and 1000 A (D1...D4) are equipped with field exciters.

The power section of the converters is available as single (2-Q) bridge or double (4-Q) bridge. 4-Q drives are required for regenerative braking. 4-Q drives can be built by:

- Double (4-Q) armature bridge or
- Single (2-Q) armature bridge plus field converter bridge with double bridge

Reference variables

The voltage characteristics are shown in the table beside. The DC voltage characteristics have been calculated using the following assumptions:

- U_{VN} = rated input terminal voltage, 3-phase
- Voltage tolerance $\pm 10\%$
- Internal voltage drop approx. 1%
- If a deviation or a voltage drop has to be taken into consideration in compliance with IEC and VDE standards, the output voltage or the output current must be reduced by the actual factor according to the table on the right.

The bridge type has an influence on the maximum output voltage of the converter. See table below.

System connection voltage	DC voltage (recommended)		Ideal DC voltage without load	Recommended DCS800 Voltage class
	$U_{dmax\ 2-Q}$	$U_{dmax\ 4-Q}$		
U_{VN} [M]	[M]	[M]	U_{dio} [M]	
230	265	240	310	04
380	440	395	510	04
400	465	415	540	04
415	480	430	560	04
440	510	455	590	05
460	530	480	620	05
480	555	500	640	05
500	580	520	670	05
525	610	545	700	06 *
575	670	600	770	06
600	700	625	810	06
660	765	685	890	07
690	800	720	930	07
800	915	820	1060	08
990	1160	1040	1350	10
1200	1380	1235	1590	12

* Sizes D1...D4 - voltage class 05 can be used

If armature voltages higher than recommended are requested, please check carefully, whether your system is still working under safe conditions.

The maximum output voltage of a 4-Q drive can be increased up to the level of $U_{dmax\ 2-Q}$ if the torque reversal time motor --> regenerative mode is increased up to 300 ms.

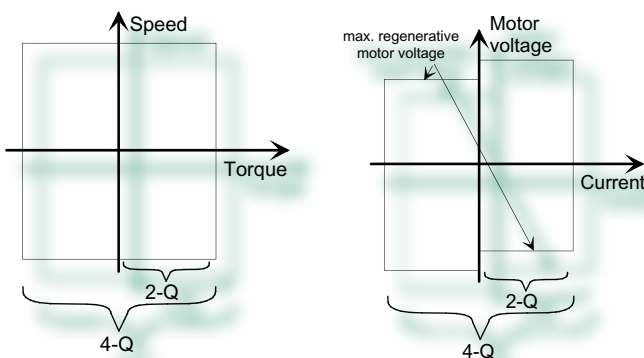

Ratings, types and voltages



Current ratings, dimensions and weights



Unit size	2-Q rated Current DCS800-S01 I_{DC} [A]	4-Q rated Current DCS800-S02 I_{DC} [A]	Supply voltage $[V_{AC}]$							Weight [kg]	Dimensions	
			400	500	600	690	800	990	1200		h x w x d [mm]	h x w x d [inch]
D1	20	25	●	●						11	310 x 270 x 200	12.50 x 10.75 x 8.00
	45	50	●	●								
	65	75	●	●								
	90	100	●	●								
	125	140	●	●								
D2	180	200	●	●					16	310 x 270 x 270	13.75 x 10.75 x 10.75	
	230	260	●	●								
D3	315	350	●	●	● ³⁾				25	400 x 270 x 310	15.75 x 10.75 x 12.50	
	405	450	●	●								
	470	520	●	●								
D4	610	680	●	●	● ³⁾				38	580 x 270 x 345	23.00 x 10.75 x 13.75	
	740	820	●	●								
	900	1000	●	●								
D5	900	900	●	●	●	●			110	1050 x 510 x 410	41.50 x 20.25 x 16.25	
	1200	1200	●	●								
	1500	1500	●	●	● ¹⁾	● ¹⁾						
	2000	2000	●	●								
D6	1900	1900		●	●	●	●		180	1750 x 460 x 410	69.00 x 18.25 x 16.25	
	2050	2050		●	●	●	●					
	2500	2500	●	●	●	●	●					
	3000	3000	●	●	●	●	●					
D7	2050	2050						●	315	1750 x 760 x 570	69.00 x 30.00 x 22.50	
	2600	2600						● ²⁾				
	3300	3300	●	●	●	●	●	● ²⁾				
	4000	4000	●	●	●	●	●					
	4800	4800	●	●	●	●	●					
	5200	5200	●	●	●	●	●					

● ¹⁾ only available as 2-Q drive
 ● ²⁾ on request
 ● ³⁾ 600V
 2-Q -> 290 A / 590 A
 4-Q -> 320 A / 650 A

Current ratings

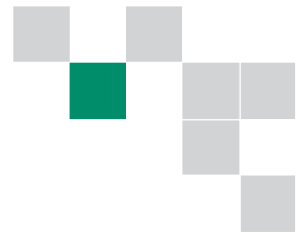

The current ratings for the DCS800 with 50 Hz and 60 Hz supplies are given below. The symbols are described below the table. The characteristics are based on an ambient temperature of max. 40°C and an elevation of max. 1000m a.s.l.

Unit type 2-Q converters	P _{out} ④		Unit type 4-Q converters	P _{out} ④		int. field current	Fan volt.	Air volume	P _{Loss}	Frame size		
	IDC I	[A]		[kW]	[kW]						IDC I	[A]
	[A]	[kW]	[kW]	[A]	[kW]	[kW]	[V AC]	[m³/h]	[kW]			
400 V / 500 V / 525 V		400V	500V		400V	500V						
DCS800-S01-0020-04/05	20	9	12	DCS800-S02-0025-04/05	25	10	13	6	without fan	300	0.11	D1
DCS800-S01-0045-04/05	45	21	26	DCS800-S02-0050-04/05	50	21	26	6	115/230; 1-ph	300	0.17	D1
DCS800-S01-0065-04/05	65	30	38	DCS800-S02-0075-04/05	75	31	39	6		300	0.22	D1
DCS800-S01-0090-04/05	90	42	52	DCS800-S02-0100-04/05	100	42	52	6		300	0.28	D1
DCS800-S01-0125-04/05	125	58	73	DCS800-S02-0140-04/05	140	58	73	6		300	0.38	D1
DCS800-S01-0180-04/05	180	84	104	DCS800-S02-0200-04/05	200	83	104	15		300	0.56	D2
DCS800-S01-0230-04/05	230	107	133	DCS800-S02-0260-04/05	260	108	135	15		300	0.73	D2
DCS800-S01-0315-04/05	315	146	183	DCS800-S02-0350-04/05	350	145	182	20		600	0.91	D3
DCS800-S01-0405-04/05	405	188	235	DCS800-S02-0450-04/05	450	187	234	20		600	1.12	D3
DCS800-S01-0470-04/05	470	213	280	DCS800-S02-0520-04/05	520	218	276	20		600	1.32	D3
DCS800-S01-0610-04/05	610	284	354	DCS800-S02-0680-04/05	680	282	354	25		950	1.76	D4
DCS800-S01-0740-04/05	740	344	429	DCS800-S02-0820-04/05	820	340	426	25	950	2.14	D4	
DCS800-S01-0900-04/05	900	049	522	DCS800-S02-1000-04/05	1000	415	520	25	1900	2.68	D4	
DCS800-S01-1200-04/05	1200	558	696	DCS800-S02-1200-04/05	1200	498	624	25 ③	800	5.10	D5	
DCS800-S01-1500-04/05	1500	698	870	DCS800-S02-1500-04/05	1500	623	780	25 ③	800	5.30	D5	
DCS800-S01-2000-04/05	2000	930	1160	DCS800-S02-2000-04/05	2000	830	1040	25 ③	800	6.60	D5	
DCS800-S01-2050-05	2050	953	1189	DCS800-S02-2050-05	2050	851	1066	-	1600	8.00	D6	
DCS800-S01-2500-04/05	2500	1163	1450	DCS800-S02-2500-04/05	2500	1038	1300	-	400-500; 3-ph	1600	9.00	D6
DCS800-S01-3000-04/05	3000	1395	1740	DCS800-S02-3000-04/05	3000	1245	1560	-	1600	11.10	D6	
DCS800-S01-3300-04/05	3300	1535	1914	DCS800-S02-3300-04/05	3300	1370	1716	-	4200	11.70	D7	
DCS800-S01-4000-04/05	4000	1860	2320	DCS800-S02-4000-04/05	4000	1660	2080	-	400/690; 3-ph	4200	13.00	D7
DCS800-S01-5200-04/05	5200	2418	3016	DCS800-S02-5200-04/05	5200	2158	2704	-	4200	19.00	D7	
600 V / 690 V		600V	690V		600V	690V						
DCS800-S01-0290-06	290	203		DCS800-S02-0320-06	320	200		-	115/230; 1-ph	600	0.91	D3
DCS800-S01-0590-06	590	413		DCS800-S02-0650-06	650	405		-	230; 1-ph ①	950	1.86	D4
DCS800-S01-0900-06/07	900	630	720	DCS800-S02-0900-06/07	900	563	648	25 ③	230; 1-ph	800	5.10	D5
DCS800-S01-1500-06/07	1500	1050	1200	DCS800-S02-1500-06/07	1500	938	1080	25 ③		800	6.30	D5
DCS800-S01-2000-06/07	2000	1400	1600					25 ③		800	8.10	D5
DCS800-S01-2050-06/07	2050	1435	1640	DCS800-S02-2050-06/07	2050	1281	1476	-	525-690; 3-ph ②	1600	9.20	D6
DCS800-S01-2500-06/07	2500	1750	2000	DCS800-S02-2500-06/07	2500	1563	1800	-		1600	10.20	D6
DCS800-S01-3000-06/07	3000	2100	2400	DCS800-S02-3000-06/07	3000	1875	2160	-		1600	12.20	D6
DCS800-S01-3300-06/07	3300	2310	2640	DCS800-S02-3300-06/07	3300	2063	2376	-		4200	13.10	D7
DCS800-S01-4000-06/07	4000	2800	3200	DCS800-S02-4000-06/07	4000	2500	2880	-	400/690; 3-ph	4200	15.10	D7
DCS800-S01-4800-06/07	4800	3360	3840	DCS800-S02-4800-06/07	4800	3000	3456	-	4200	19.50	D7	
800 V		800V			800V							
DCS800-S01-1900-08	1900	1739		DCS800-S02-1900-08	1900	1558		-	400-500; 3-ph	1600	9.00	D6
DCS800-S01-2500-08	2500	2288		DCS800-S02-2500-08	2500	2050		-		1600	10.70	D6
DCS800-S01-3000-08	3000	2745		DCS800-S02-3000-08	3000	2460		-		1600	12.70	D6
DCS800-S01-3300-08	3300	3020		DCS800-S02-3300-08	3300	2706		-		4200	13.40	D7
DCS800-S01-4000-08	4000	3660		DCS800-S02-4000-08	4000	3280		-	400/690; 3-ph	4200	15.60	D7
DCS800-S01-4800-08	4800	4392		DCS800-S02-4800-08	4800	3936		-	4200	20.00	D7	
990 V		990V			990V							
DCS800-S01-2050-10	2050	2378		DCS800-S02-2050-09	2050	2132		-	400/690; 3-ph	4200	9.70	D7
DCS800-S01-2600-10	2600	3016		DCS800-S02-2600-09	2600	2704		-		4200	12.10	D7
DCS800-S01-3300-10	3300	3828		DCS800-S02-3300-09	3300	3432		-		4200	16.60	D7
DCS800-S01-4000-10	4000	4640		DCS800-S02-4000-09	4000	4160		-		4200	20.20	D7
1200 V	Data on request											

① with plus code 115 V selectable

② with plus code 400-500 V selectable

③ FEX425 internal field exciter as option; three-phase or single phase, separate supply max. 500 V AC

④ ratings for rated input voltage -10%

Environmental Conditions

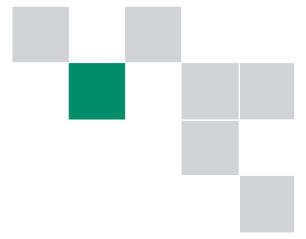

System connection	
Voltage, 3-phase:	230 to 1000 V acc. to IEC 60038
Voltage deviation:	±10% continuous; ±15% short-time *
Rated frequency:	50 Hz or 60 Hz
Static frequency deviation:	50 Hz ±2 %; 60 Hz ±2 %
Dynamic: frequency range:	50 Hz: ±5 Hz; 60 Hz: ± 5 Hz
df/dt:	17 % / s
* = 0.5 to 30 cycles.	
Please note: Special consideration must be taken for voltage deviation in regenerative mode.	
Degree of protection	
Converter Module and options (line chokes, fuse holder, field supply unit, etc.):	IP 00
Enclosed converters:	IP 20/21/31/41
Paint finish	
Converter module:	RAL 9002
Enclosed converter:	light grey RAL 7035

Sound pressure level

Size	Sound pressure level L _p (1 m distance)		Vibration
	as module	enclosed conv.	
D1	55 dBA	?? dBA	0.5 g, 5...55 Hz
D2	55 dBA	?? dBA	
D3	60 dBA	?? dBA	
D4	66...70 dBA, depending on fan	77 dBA	
D5	73 dBA	78 dBA	1 mm, 2...9 Hz 0.3 g, 9...200 Hz
D6	75 dBA	73 dBA	
D7	82 dBA	80 dBA	

Environmental limit values	
Permissible cooling air temperatur.	
- at converter module air inlet:	0 to +55°C
with rated DC current:	0 to +40°C
w. different DC current	+30 to +55°C
- Options:	0 to +40°C
Relative humidity (at 5...+40°C):	5 to 95%, no condensation
Relative humidity (at 0...+5°C):	5 to 50%, no condensation
Change of the ambient temp.:	< 0.5°C / minute
Storage temperature:	-40 to +55°C
Transport temperature:	-40 to +70°C
Pollution degree (IEC 60664-1, IEC 60439-1):	2
Site elevation	
<1000 m above M.S.L.:	100%, without current reduction
>1000 m above M.S.L.:	with current reduction

North American Standards

In North America the system components fulfil the requirements of the table below.

Rated supply voltage	Standards	
	Converter module	Enclosed converter
to 600 V	UL 508 C Power Conversion Equipment CSA C 22.2 No. 14-95 Industrial Control Equipment, Industrial Products Available for converter modules including field exciter units. Types with UL mark: • see UL Listing www.ul.com / certificate no. E196914 • or on request	UL/CSA types: on request
>600 V to 1000 V	EN / IEC xxxxx see table above. Available for converter modules including field exciter units.	EN / IEC types: on request (for details see table above)

Regulatory Compliance

The converter module and enclosed converter components are designed for use in industrial environments. In EEA countries, the components fulfil the requirements of the EU directives, see table below.

European Union Directive	Manufacturer's Assurance	Harmonized Standards	
		Converter module	Enclosed converter
Machinery Directive 98/37/EEC 93/68/EEC	Declaration of Incorporation	EN 60204-1 [IEC 60204-1]	EN 60204-1 [IEC 60204-1]
Low Voltage Directive 73/23/EEC 93/68/EEC	Declaration of Conformity	EN 60146-1-1 [IEC 60146-1-1] EN 61800-5-1 (EN 50178 [IEC --]) see additional IEC 60664	EN 60204-1 [IEC 60204-1] EN 61800-5-1 EN 60439-1 [IEC 60439-1]
EMC Directive 89/336/EEC 93/68/EEC	Declaration of Conformity (Provided that all installation instructions concerning cable selection, cabling and EMC filters or dedicated transformer are followed.)	EN 61800-3 ① [IEC 61800-3] ① in accordance with 3ADW 000 032	EN 61800-3 ① [IEC 61800-3] ① in accordance with 3ADW 000 032/3ADW 000 091

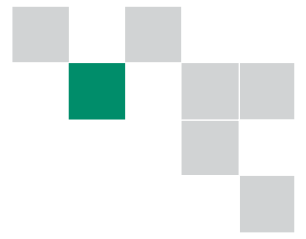

Components overview of converter size D5...D7

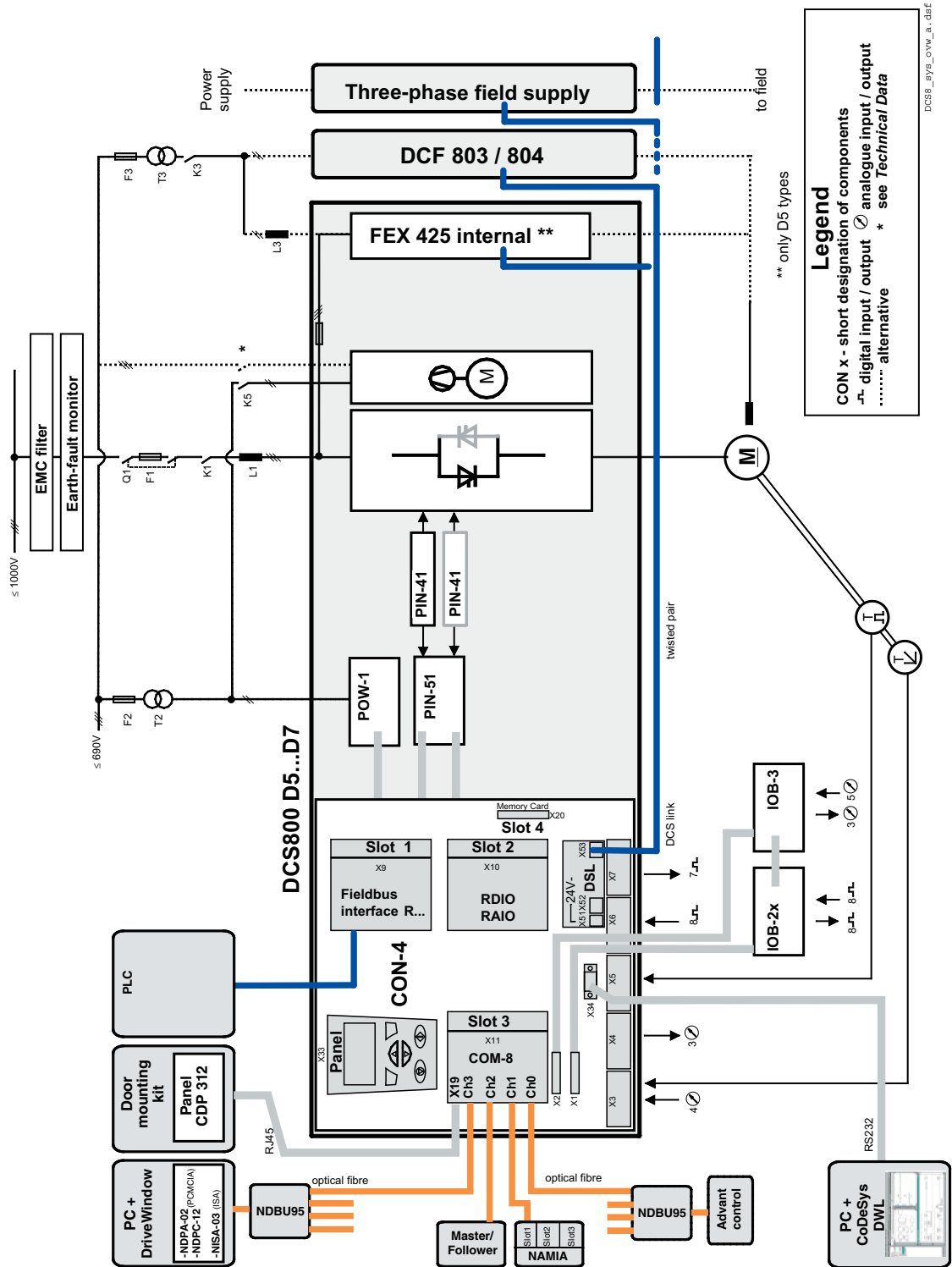

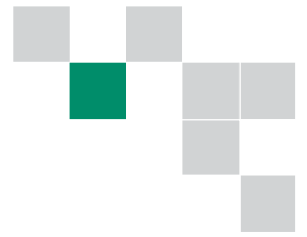

Dimensioning DriveSize

Quality dimensioning

DriveSize is a PC program for helping the user to select an optimal converter and options, especially in those cases where a straightforward selection from a catalogue is not possible. Documents about the dimensioning based on actual load.

The default values make DriveSize simple to use, but the user is provided with many options for drive selection. The shortcut keys make drive selection easy while still honouring the relatively complicated rules. A manual selection mode is also supported.

DriveSize is currently used by more than 1000 engineers globally.

DriveSize is for drive system components

- DCS converter modules
- DCS enclosed converters
- Group drives (line-ups)
- Drive options

DriveSize features

- Select an drive unit, incoming unit
- Calculate duty load cycles for converters
- Supply dimensioning results in graphical and numerical format
- Print and save the results

The screenshot displays the DriveSize 2.4 software interface. It includes a 'Welcome to DriveSize 2.4' dialog box, a 'System configuration' tree showing a hierarchy of drives and converters, a 'Converter load' panel with various parameters like 'Load type', 'Duty cycle', and 'Short time current', and a 'Selected converter data' table. A 'Drivers' window is open, showing a list of drivers with columns for Name, Code, Qty, and Unit. A 'Load profile' graph is visible at the bottom, plotting Load [%] against Time [s].

Parameter	Value
Selection method	Standard
Rated AC supply [V]	400
Rated AC current [A]	1000
Max DC voltage [V]	1000
Catalogue [DC-1] [A]	1000
Rated duty type [A]	1000
Quadrant type	2-quadrant
Modular Enclosed	No
With Air Filter	No
Field reversal	No
Protection class	IP21

Name	Code	Qty	Unit
Standard-Kit. Mod.			
Advanced control			
Name plate			
Power switching			
Field switch			
Documentation			
AC5000			
Auxiliary supply [V]	380		
AC Field supply [V]	400		
Options in the group:			
Fieldbus link to drive			
Fieldbus adapter modules for DCAS00			
for Profibus, NPBA-12	0	0	0
for Modbus, MABA-01	0	0	0
for CANopen NCAN-02	0	0	0
for DeviceNet NDNA-02	0	0	0
Power supply 230VAC/200VDC 3A, NPSM-01	0	0	0
I/O Digital Connection board			
Standard SDCS-40B-23 (230V control voltage + 230V)	0	0	0
Changing to SDCS-40B-21 (230V control voltage, 40V)	1	1	700
Changing to SDCS-40B-22 (115V control voltage, 11V)	0	0	0
I/O extension board			
SDCS-40B-1 (with process terminals; don't forget 24V)	0	0	0
Adaption board for analog latch			
PSS311-SE1 (for board latch gain adjust by Prof)	0	0	0
DC Transducer I. with customer measurement, (max 2 or 4 PT 110 measurement unit for each 230V module)	1	1	41
Discount [K]	0		
Total list price			ABB
Total net price			ABB

Easy Commissioning



General

Easy-to-use saves customer time consumption and keeps required training low. Easy commissioning is based on three columns.

- DCS800 is equipped with macros to cover the most frequent parameter settings.
- Assistance guide through required parameter setting during commissioning and all auto-tunings.
- Adaptive programming provides a very flexible set of function blocks and solves problems during commissioning.

DCS800 Macros

DCS800 is equipped with seven different macros to cover the most frequent parameter settings. Macros are pre-programmed parameter sub-sets. During startup, the drive can be configured easily without changing individual parameters. The functions of all inputs and several outputs and of allocations in the control structure are influenced by the selection of a macro. This means, whether the drive is speed-controlled or torque-controlled, whether supplementary references are processed, which actual values are available at the analog outputs, which reference value sources are used etc. is already defined in the macro.

		Terminal Allocation by Macros						
Terminal	Signal	Factory	Standard	Manual / constant speed	Hand / auto	Hand / motor pot	Motor pot	Torque control
X3:	1 90...270 V AITAC-	-	-	-	-	-	-	-
	2 30...90 V AITAC-	-	-	-	-	-	-	-
	3 8...30 V AITAC-	-	-	-	-	-	-	-
	4 AITAC+	-	-	-	-	-	-	-
	5 AI1-	-	-	-	-	-	-	-
	6 AI1+	-	Speed reference	Speed reference	Speed reference	Speed reference	-	Torque reference
	7 AI2-	-	-	-	-	-	-	-
	8 AI2+	-	Torque limit	-	-	-	-	-
	9 AI3-	-	-	-	-	-	-	-
	10 AI3+	-	-	-	-	-	-	-
X4:	1 AI4-	-	-	-	-	-	-	-
	2 AI4+	-	-	-	-	-	-	-
	3 0 V	-	-	-	-	-	-	-
	4 +10 V	-	-	-	-	-	-	-
	5 -10 V	-	-	-	-	-	-	-
	6 0 V	-	-	-	-	-	-	-
	7 AO1	-	Motor speed	Motor speed	Motor speed	Motor speed	Motor speed	Motor speed
	8 AO2	-	Actual armat. volt.	Actual motor curr.	Actual motor curr.	Actual motor curr.	Actual armat. volt.	Motor torque
	9 IACT	Actual current	Actual current	Actual current	Actual current	Actual current	Actual current	Actual current
	10 0 V	-	-	-	-	-	-	-
X5:	1 Ch A+	-	-	-	-	-	-	-
	2 Ch A-	-	-	-	-	-	-	-
	3 Ch B+	-	-	-	-	-	-	-
	4 Ch B-	-	-	-	-	-	-	-
	5 Ch Z+	-	-	-	-	-	-	-
	6 Ch Z-	-	-	-	-	-	-	-
	7 0 V	-	-	-	-	-	-	-
	8 Sense 0 V	-	-	-	-	-	-	-
	9 Power out +	-	-	-	-	-	-	-
	10 Sence power out +	-	-	-	-	-	-	-
X6:	1 DI1	Converter fan ack.	Jog1	Jog1	StartStop	Motor pot up	Direction	Off2 (coast stop)
	2 DI2	Motor fan ack.	Jog2	Jog2	HandAuto	Motor pot down	Motor pot up	Torque select
	3 DI3	Main contact. ack.	External fault	Direction	Direction	Direction	Motor pot down	External fault
	4 DI4	Off2 (coast stop)	External alarm	Parameter select	Speed ref. select	Speed ref. select	Motor pot minimum	-
	5 DI5	E-Stop	E-Stop	E-Stop	E-Stop	E-Stop	E-Stop	E-Stop
	6 DI6	Reset	Reset	Reset	Reset	Reset	Reset	Reset
	7 DI7	OnOff1	OnOff1	On Start pulse	OnOff1	On Start pulse	OnOff1	OnOff1
	8 DI8	StartStop	StartStop	Off1 Stop pulse NC	-	Off1 Stop pulse NC	StartStop	StartStop
	9 +24 V	-	-	-	-	-	-	-
	10 0 V	-	-	-	-	-	-	-
X7:	1 DO1	Fans On cmd.	ReadyRun	ReadyOn	ReadyOn	ReadyOn	ReadyRun	ReadyRun
	2 DO2	Field excit. On cmd.	ReadyRef (running)	ReadyRef (running)	ReadyRef (running)	ReadyRef (running)	Above limit	ReadyRef (running)
	3 DO3	Main contact. On cmd.	Fault or alarm	Tripped (fault)	Tripped (fault)	Tripped (fault)	Fault or alarm	Fault or alarm
	4 DO4	-	Zero speed	Zero speed	Zero speed	Zero speed	Zero speed	Zero speed
	5 DO5	-	Above limit	Above limit	Above limit	Above limit	At setpoint	Zero speed DC-breaker trip cmd.
	6 DO6	-	-	-	-	-	-	-
	7 DO7	-	-	-	-	-	-	-
	8 0 V	-	-	-	-	-	-	-
X96:	1 DO8 Relay	Main contact. On cmd.	-	-	-	-	-	
	2	-	-	-	-	-	-	
Serial communication		Speed reference	-	-	Speed reference	-	-	

Startup Assistant

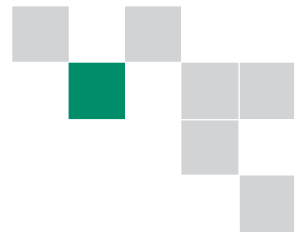

Faster and easier commissioning

The Startup Assistant serves in DCS800 DC Drives. It guides you actively through the commissioning procedure either by the control panel or ABB PC tools. It is multilingual, requests data with clear and plain text messages, and sets the required parameters to your needs. It also comes with an online info system with step-by-step reference to printed manuals.

On-line info system

To make it easier and more informative, there is an on-line info system available at each step, helping to set the correct values for each parameter and troubleshoot the problems.

Startup Assistant Features

- Easy and fast commissioning procedure
- Intelligent guide to assist you through the commissioning
- Your own language
- On-line info system always available
- Auto detection of connected hardware

The DCS800 DC Drive offers you all this as standard features.



Adaptive Programming

Optimal adaptability

- Small PLC inside.
- Program your drive on-site during commissioning.
- Create your own I/O signals, modify speed or torque reference, chain or set a timer.
- Do it without any additional hardware or software.
- As simple as setting a parameter.
- Access to any signal or control bit.

There is also a DWL AP PC tool available for graphical display of Adaptive Programming.



Adaptive Programming Features

- 16 programmable function blocks
- Available functions:
 - Logical: AND, OR and XOR
 - Mathematical: add, mul, div, abs, max and min
 - Other: timer, switch, comparator, filter, SR, PI and user-defined warnings or faults
- Freely definable execution order
- Easy documentation

The DCS800 DC Drive offers you all this as standard features.

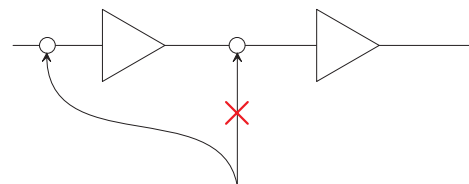



DCS800 Basic firmware

DCS800 firmware includes the basic function of speed control, armature current, field current and motor voltage. The flexible design for command location enables field bus control or master-follower control or control from hardware signals as well as a mixed structure. The design of drive logic enables a drive reaction defined by Profibus standard but can also be configured to adapt classic command structures.

The firmware interface for several fieldbuses and module bus is included. All parameters can be accessed by the serial communication or by IEC 61131 or adaptive programming.

Five macros are predefined and two user macros can be configured by the customer.

Functions of basic firmware

- Different speed ramp function
- Speed control
- Torque control
- Armature current control
- Field current control
- Automatic field weakening
- E-stop function according to profibus standard
- Dual field control
- Mechanical brake control
- DC breaker control
- Interface for fieldbus and module bus
- Programmable digital and analogue outputs
- Master follower bus
- 16 blocks Adaptive Program
- Interface for IEC 61131 programming
- 12-pulse function - parallel, serial, sequential
- 3-phase field exciter operation
- Converter protection (temperature, voltage,...)

Motor protections

- Stall protections
- Thermal motor model
- 2 channel motor temperature measurement PTC or PT100
- Klixon supervision
- Speed feedback error
- Over speed
- Armature current ripple
- Armature over current
- Minimum field current

Master-Follower Applications

Drives connected in Master-Follower application

If motors run with the same speed / torque connected to the same shaft or gearbox are called MASTER - FOLLOWER.

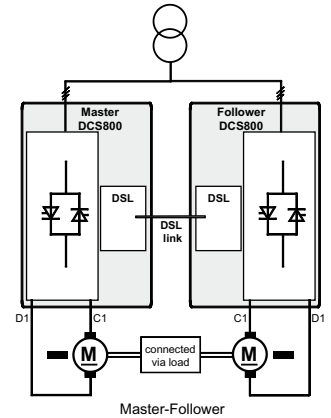

Quasi 12-pulse Master-Follower configuration

The converters are fed by a 12-pulse transformer with separated secondary windings whose phase positions differ by 30°el.

This configuration delivers the same advantages concerning harmonics to the network as a standard 12-pulse application (see next item), but no T-reactor is needed.

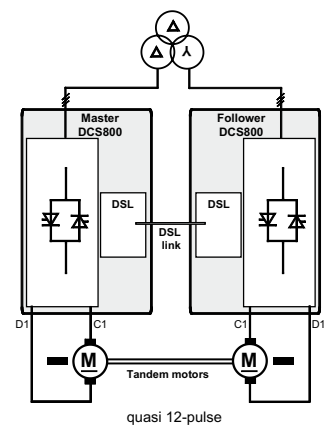

Typical configuration for high power drives connected in 12-pulse parallel, serial or sequential application

12-pulse systems are used for reduced line harmonics, reduced motor noise level, enlarged output current or voltage of converter system. Only the 11th and 13th, the 23rd and 25th, the 35th a.s.o. are existing. The harmonics on the DC side are reduced too, which gives a higher efficiency.

It is **not** possible to connect two 12-pulse systems (2 converters, T-reactor and 1 motor) to one 12-pulse transformer. For more information, please see *manual 12-pulse operation*.

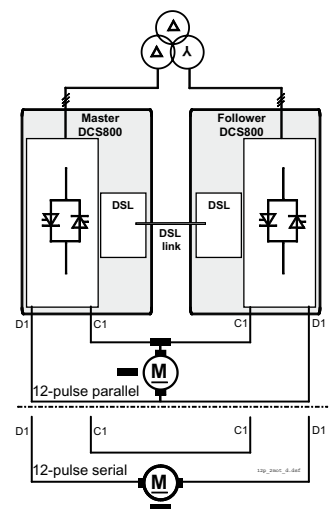

Plug-in options

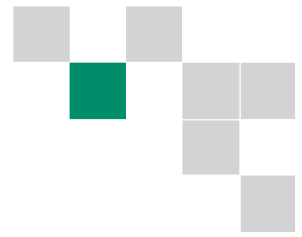

DCS800 - S01 - 0025 - 04 + B055

Basic control panel

The basic control panel features a single line numeric display. The panel can be used to control the drive, set the parameter values or copy them from a drive to another one. It comes with every DCS800.

plus code

- +0J400 If no control panel is required
- +J404 Basic control panel DCS800PAN
- Panel mounting kit ACS/H-CP-EXT plus cable

Plug-in fieldbus module

The plug-in fieldbus options bring connectivity to major automation systems. A single twisted pair avoids large amounts of conventional cabling, thereby reducing cost and increasing system reliability. The board must be located in slot1.

For plus codes see *Fieldbus control* (page 21)

I/O extension option module

This plug-in option offers two additional relay outputs. They can be used, for example, in a master-follower application for interlocking functions. All the relays can be programmed to on/off by parameter. Alternatively, fieldbus can be used to control any external components in the system.

plus code

- +L501 RDIO-01 Digital extension module 3xDI, 2xDO
- +L500 RAIO-01 Analog extension module 2xAI, 2xAO

Fast optical DDCS communication module

DCS800 provides an interface SDCS-COM-8 fast serial communication:

- Master channel Module bus to AC800M
- I/O channel to AIMA-01 board
- Master-Follower DDCS channel
- Tools channel e.g DriveWindow, Remote diagnostic NETA, as well as the CDP 312 from ACS800 range can be connected on this board
- The board must be located in slot3.

plus code

- +L508 Module bus 10 Mbd (SDCS-COM-81)
- +L509 NxxA fieldbus adapter 5 Mbd (SDCS-COM-82)

Drive-specific serial communication board

The SDCS-DSL board provides the serial communication for:

- Drive to drive
- Drive to external field exciter
- 12-pulse applications

plus code

- +S199 SDCS-DSL communication board



External Field Supply



General data

- Currents from 0.3 to 520 A
- Minimum field current monitor
- Integrated external field power converter or completely separate switchgear cubicle
- single-phase or 3-phase model
- Controlled by serial communication via DSL board

All field converters are controlled by the armature converter via a serial interface (SDCS-DSL Board). This interface serves to parameterize, control and diagnose the field converter and thus provides an option for exact control.

We recommend integrating an autotransformer in the field power converter's supply circuit to adjust the AC input voltage to the field voltage and for reducing the voltage ripple in the field circuit **for single-phase** operation.

Field converter types

DCF803-0035

- Half-controlled thyristor/diode bridge (1-Q)
- Three-phase or single-phase operation
- Microprocessor control, with the electronic system being supplied by the armature-circuit converter (24 V).
- Construction and components have been designed for an insulation voltage of 600 V AC.
- Fast-response excitation is possible with an appropriate voltage reserve; de-excitation takes place by field time constant.
- Output voltage U_A (single-phase operation):



$$U_A \leq U_V * \left(\frac{100\% + TOL}{100\%} \right) * 0.9$$

TOL = tolerance of line voltage in %

U_V = Line voltage

- Recommendation (single-phase operation):
Field voltage 0.6 to 0.8 * U_V

- Output voltage U_A (three-phase operation):

$$U_A \leq U_V * \left(\frac{100\% + TOL}{100\%} \right) * 1.35$$

TOL = tolerance of line voltage in %

U_V = Line voltage

Note: Calculation valid also for FEX425 internal

Table of field converter units

Unit type	Output current I_{DC}	AC field supply voltage	auxiliary supply voltage	Remarks
DCF803-0035	0.3...35 A	110V -15%...500V/1-ph +10% single-phase or three-phase	24 V DC 200 mA	external fuse for 3-phase operation use ND01, ND02 for 1-phase operation use ND30 \Rightarrow 16A
DCF803-0050	0.3...50 A	110V -15%...500V/1-ph +10%	115 or 230 V	if necessary via matching autotransformer; fuse external; Dimensions HxWxD: 370x125x342 [mm]
DCF804-0050	0.3...50 A	110V -15%...500V/1-ph +10%		
DCS800-S0x-xxxx-05	see table on page 7	200V...500V/3-ph		

Current reduction see also *Environmental conditions* in *Hardware manual*

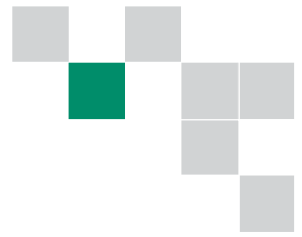

DCF803-0050

- Single-phase power stack
- Half-controlled thyristor/diode bridge (1-Q).
- Built-in line chokes.
- Microprocessor control with the control electronics being supplied separately (115...230 V/1-ph).
- Construction and components have been designed for an insulation voltage of 690 V AC.



- Output voltage U_A :

$$U_A \leq U_V * \left(\frac{100\% + TOL}{100\%} \right) * 0.9$$

TOL = tolerance of line voltage in %
 U_V = Line voltage

- Recommendation:
 Field voltage 0.6 to 0.8 * U_V

DCF804-0050

- Single-phase power stack
- Fully-controlled antiparallel thyristor bridges (4-Q)
- This unit offers field reversal as well as fast-response excitation / de-excitation.

In the steady-state condition, the fully-controlled bridge runs in half-controlled mode so as to keep the voltage ripple as low as possible. With a quickly alternating field current, the bridge runs in fully-controlled mode.

- Same design as DCF803.
- Built-in line chokes.

Autotransformer for single-phase field supply

for field current I_f	Autotransformer type 50/60 Hz	DCF803-0035 FEX 425 internal	DCF803-0050 DCF804-0050
	$U_{prim} = \leq 500 V$		
$\leq 6 A$	T 3.01	x **	x
$\leq 12 A$	T 3.02	x **	x
$\leq 16 A$	T 3.03	x **	x
$\leq 30 A$	T 3.04	x *	x
$\leq 50 A$	T 3.05		x
	$U_{prim} = \leq 600 V$		
$\leq 6 A$	T 3.11	x **	x
$\leq 12 A$	T 3.12	x **	x
$\leq 16 A$	T 3.13	x **	x
	$U_{prim} = \leq 690 V$		
$\leq 30 A$	T 3.14		x
$\leq 50 A$	T 3.15		x

* three-phase operation recommended

** requires ND 30 line choke

DCS800

This converter can also be used for field exciter operation, an additional over-voltage protection unit is required. It provides field currents from 25 A up to 520 A unipolar and bipolar for field reversal function.



- Output voltage U_A respectively $U_{dmax 2-Q}$:
 see table on page 5
- Recommendation:
 Field voltage 0.5 to 1.1 * U_V
- The three-phase field supply converters DCS800-S01/S02 need a separate active Overvoltage Protection unit DCF 506 for protecting the power part against inadmissibly high voltages.
 The overvoltage protection unit DCF 506 is suitable for 2-Q converters DCS800-S01 and for 4-Q converters DCS800-S02.

Assignment of field supply converter to Overvoltage protection unit

Field supply converter for motor fields	Overvoltage Protection
DCS80x-0020-51	DCF506-0140-51
...	
DCS80x-0140-51	
DCS80x-0200-51	DCF506-0520-51
...	
DCS80x-0520-51	



DCF506-140-51, without cover

Fuse connections



Recommended fuse connections see tables below.

Semiconductor type F1 fuses and fuse holders for AC and DC power lines (DCS800-S01 / DCS800-S02)

The converter units are subdivided into two groups:

- Unit sizes D1, D2, D3 and D4 with rated currents up to 1000 A require external line fuses.
- In unit sizes D5, D6 and D7 with rated currents of 900 A to 5200 A, the semiconductor fuses are installed internally (no additional external semiconductor fuses are needed).

The table assigns the AC fuse types to the converter types. In case the converter should be equipped with DC fuses according to the hints use the same type of fuse used on the AC side now in the plus and minus line. Blade type fuses are used for all the converters of construction type D1...D4 except the converters (610 A, 680 A, 740 A, 820 A, 900 A, 1000 A)

Type of converter		Type	Fuse holder	Design fig.
2-Q Converter	4-Q Converter			
DCS800-S01-0020-04/05	DCS800-S02-0025-04/05	170M 1564	OFAX 00 S3L	1
DCS800-S01-0045-04/05	DCS800-S02-0050-04/05	170M 1566	OFAX 00 S3L	1
DCS800-S01-0065-04/05	DCS800-S02-0075-04/05	170M 1568	OFAX 00 S3L	1
DCS800-S01-0090-04/05	DCS800-S02-0100-04/05	170M 1568	OFAX 00 S3L	1
DCS800-S01-0125-04/05	DCS800-S02-0140-04/05	170M 3815	OFAX 1 S3	1
DCS800-S01-0180-04/05	DCS800-S02-0200-04/05	170M 3816	OFAX 1 S3	1
DCS800-S01-0230-04/05	DCS800-S02-0260-04/05	170M 3817	OFAX 1 S3	1
DCS800-S01-0315-04/05	DCS800-S02-0350-04/05	170M 5810	OFAX 2 S3	1
DCS800-S01-0405-04/05	DCS800-S02-0450-04/05	170M 6811	OFAX 3 S3	1
DCS800-S01-0470-04/05	DCS800-S02-0520-04/05	170M 6811	OFAX 3 S3	1
DCS800-S01-0610-04/05	DCS800-S02-0680-04/05	170M 6163	3x 170H 3006	2
DCS800-S01-0740-04/05	DCS800-S02-0820-04/05	170M 6163	3x 170H 3006	2
DCS800-S01-0900-04/05	DCS800-S02-1000-04/05	170M 6166	3x 170H 3006	2
DCS800-S01-0290-06	DCS800-S02-0320-06	170M 5810	OFAX 2 S3	1
DCS800-S01-0590-06	DCS800-S02-0650-06	170M 6813	OFAX 3 S3	1

Fuses and fuse holders (details see Technical Data)



Fig. 1

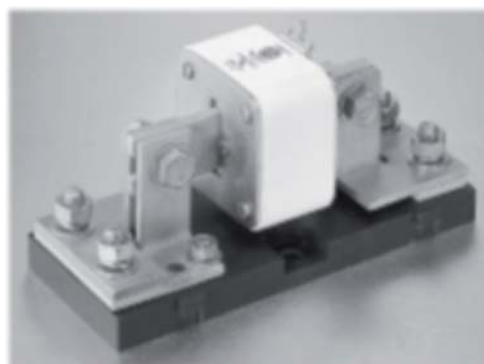

Fig. 2

Line reactors L1



DCS Type 400V-690V 50/60 Hz		Line choke type for configur. A	Design Fig.	Line choke type for configur. B	Design Fig.
2-Q Converter	4-Q Converter				
DCS800-S01-0020-04/05	DCS800-S02-0025-04/05	ND01	1	ND401	4
DCS800-S01-0045-04/05	DCS800-S02-0050-04/05	ND02	1	ND402	4
DCS800-S01-0065-04/05	DCS800-S02-0075-04/05	ND04	1	ND403	5
DCS800-S01-0090-04/05	DCS800-S02-0100-04/05	ND06	1	ND404	5
DCS800-S01-0125-04/05	DCS800-S02-0140-04/05	ND06	1	ND405	5
DCS800-S01-0180-04/05	DCS800-S02-0200-04/05	ND07	2	ND406	5
DCS800-S01-0230-04/05	DCS800-S02-0260-04/05	ND07	2	ND407	5
DCS800-S01-0290-06	DCS800-S02-0320-06	ND08	2	on request	-
DCS800-S01-0315-04/05	DCS800-S02-0350-04/05	ND09	2	ND408	5
DCS800-S01-0405-04/05	DCS800-S02-0450-04/05	ND10	2	ND409	5
DCS800-S01-0590-06	DCS800-S02-0650-06	ND13	3	on request	-
DCS800-S01-0470-04/05	DCS800-S02-0520-04/05	ND10	2	ND410	5
DCS800-S01-0610-04/05	DCS800-S02-0680-04/05	ND12	2	ND411	5
DCS800-S01-0740-04/05	DCS800-S02-0820-04/05	ND13	3	ND412	5
DCS800-S01-0900-04/05	DCS800-S02-1000-04/05	ND13	3	ND413	5
DCS800-S01-0900-06/07	DCS800-S02-0900-06/07	ND13	3	on request	-
DCS800-S01-1200-04/05	DCS800-S02-1200-04/05	ND14	3	on request	-
DCS800-S01-1500-04/05/06/07	DCS800-S02-1500-04/05/06/07	ND15	3	on request	-
DCS800-S01-2000-04/05	DCS800-S02-2000-04/05	ND16	3	on request	-
DCS800-S01-2000-06/07		ND16 *	3	on request	-

* with forced cooling



Fig. 1

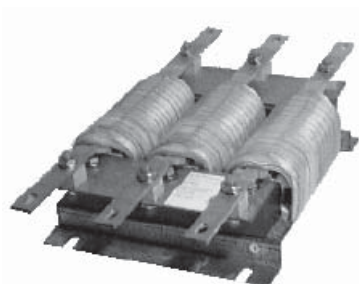

Fig. 2

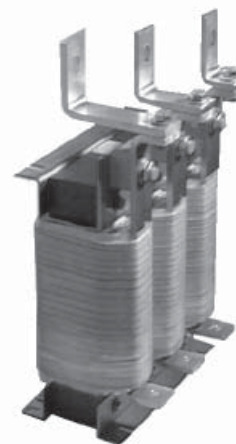

Fig. 3



Fig. 4



Fig. 5

IEC 61131 programming



ControlBuilder DCS800

The ControlBuilder is a user-friendly tool based on the IEC61131-3 standard for programming the DCS800. With the ControlBuilder it is possible to develop - in a fast and easy way - new function e.g. winders, decentralized controls, safety functions, ... directly in the drive.

The ControlBuilder is based on the common tool CoDeSys. Due to its intuitive Windows based user interface even beginners are able to start programming immediately. Additionally a set of drive specific function blocks eases the programming of the DCS800.

By means of completely supporting all five programming languages of the IEC61131-3 standard everyone is able to find the right programming environment:

- instruction list IL
- sequential function chart AS
- function block diagram FDB
- structured text ST
- ladder diagram LD
- additionally a free graphical function plan (CFC) is available

The extremely user-friendly online debugging function offers besides single step-, single cycle- and breakpoint mode an event triggered recording tool for variables and signals.

Due to the offline simulation mode it is possible to use the debugging function without connected hardware.

The application program is stored on a compact flash (Memory Card - MC), which is plugged into the drive. Thus it is possible to store the binary code as well as all source codes. Of course protection of the application program with a password is possible.

Advantages of the ControlBuilder DCS800:

- Fast and easy adaptation of DCS800 DC Drive to the used application.
- Less spare parts.
- The application, including source code, is always part of the drive and thus can be maintained during the whole live cycle of the machine.
- The source code can be password protected against unauthorized access.

Requirements:

- PC with Windows NT, 2000 or XP
- One free serial port



Memory Card

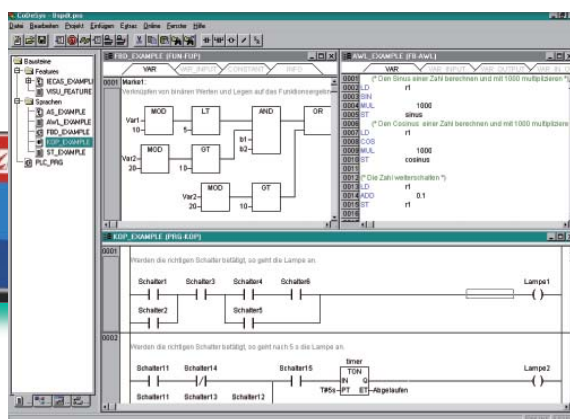

Programming



Motor



Application



Member of Automation Alliance

Fieldbus control

Gateway to your process.



DCS800 DC Drives have connectivity to major automation systems. This is achieved with a dedicated gateway concept between the fieldbus systems and ABB drives.

The fieldbus gateway module can easily be mounted inside the drive. As a result of the wide range of fieldbus gateways, your choice of automation system is independent from your decision to use first-class ABB drives.

Manufacturing flexibility

Drive control

The drive Control Word (16 bit) provides a wide variety of functions from Start, Stop and Reset to Ramp Generator control. Typical setpoint values like Speed, Torque and Position can be transmitted to the drive with 15 bit accuracy.

Drive monitoring

A set of drive parameters and/or actual signals, like torque, speed, position, current etc., can be selected for cyclic data transfer providing fast data for operators and the manufacturing process.

Drive diagnostics

Accurate and reliable diagnostic information can be obtained via the drive Alarm, Limit and Fault Words, reducing the drive downtime and therefore also the downtime of the manufacturing process.

Drive parameter handling

Total integration of the drives in the production process is achieved by single parameter read/write up to complete parameter set-up or download.

Easy to expand

Serial communication simplifies the latest trend of modular machine design enabling the installation to be expanded at a later stage with low effort.

Reduced installation and engineering effort

Cabling

Substituting the large amount of conventional drive control cabling with a single twisted pair reduces costs and increases system reliability.

Design

The use of Fieldbus Control reduces engineering time at installation due to the modular structure of the hardware and software.

Commissioning and assembly

The modular machine configuration allows pre-commissioning of single machine sections and provides easy and fast assembly of the complete installation.

Currently available gateways

- | | plus code |
|---------------|-----------|
| • PROFIBUS-DP | +K454 |
| • DeviceNet | +K451 |
| • CANopen | +K457 |
| • ControlNet | +K462 |
| • Modbus | +K458 |
| • Ethernet | |



DriveWindow Light 2 Startup and Maintenance Tool

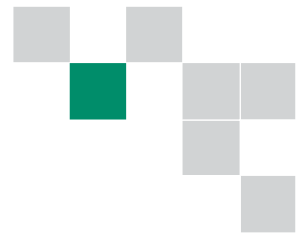

PC tool for ABB drives

DriveWindow Light 2 is an easy-to-use startup and maintenance tool for ABB drives. Supported drives are ACS140, ACS160, ACS350, ACH400, **DCS400**, ACS550, ACH550, **DCS800** and ACS800.

Highlights

- Viewing and setting parameters in offline and online mode
- Editing, saving and downloading parameters
- Comparing parameters
- Graphical and numerical signal monitoring
- Drive control
- Startup assistants
- DWL AP Tool for DCS800
- All DCS800 DC drives are equipped with DriveWindow Light

DriveWindow Light requirements

- Windows 98 / NT / 2000 / XP
- Free serial port from a PC
- Standard RS232 cable

Light software with heavy features

DriveWindow Light offers many functions in an easy-to-use package. It can be used in an offline mode, which enables parameter setting at the office even before going to the actual site. The parameter browser enables viewing, editing and saving of parameters. The parameter comparison feature makes it possible to compare parameter values between the drive and the file. With the parameter subset you can create your own parameter sets. Controlling of the drive is naturally one of the features in DriveWindow Light. Drive status and fault information keeps commissioning time low.

Name	Browser	Drive/File
95.03 M1NonCur	11	0
95.11 M1NonPldCur	1	0.3
7.01 MainCblWard	0	6
7.04 UsedMCDW	400	476
7.06 RFE CblWard	2	0
8.01 MainStatWard	300	331
8.02 AuxStatWard	3840	1840
8.05 DI StatWard	0	18
9.06 AlarmWard1	3	0
10.06 MotFanAck	NotUsed	DI2
10.20 ConvFanAck	NotUsed	DI1
10.21 MainContAck	NotUsed	DI3
11.03 Ref1Sel	A11	SpeedRef2301
15.01 IndswA01	104	0
15.05 ScalesA01	5000	10000
15.06 IndswA02	106	0
16.09 US1 Sel	Extended	Compact
22.01 AccTime1	3	20
22.02 DecTime1	3	20
24.03 Kp5	90	9
24.09 TIS	200	2500
43.06 M1KpAmCur	0.08	0.1
43.07 M1AlmCur	14	50
43.08 M1DiscontCurLim	81.81	100
43.09 M1AmL	17.39	0
43.10 M1AmR	1180	0
44.01 FldChMode	EMF	Fix

With DriveWindow Light, you can monitor up to four signals simultaneously. This can be done in both graphical and numerical format. Any signal can be set to stop the monitoring, from a predefined level.

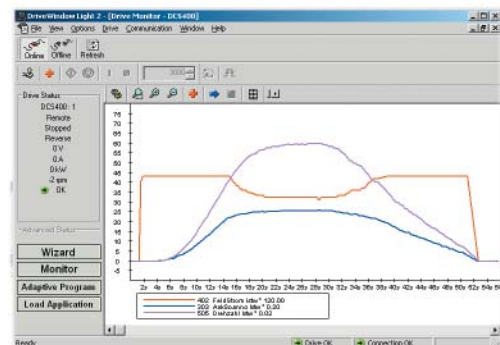
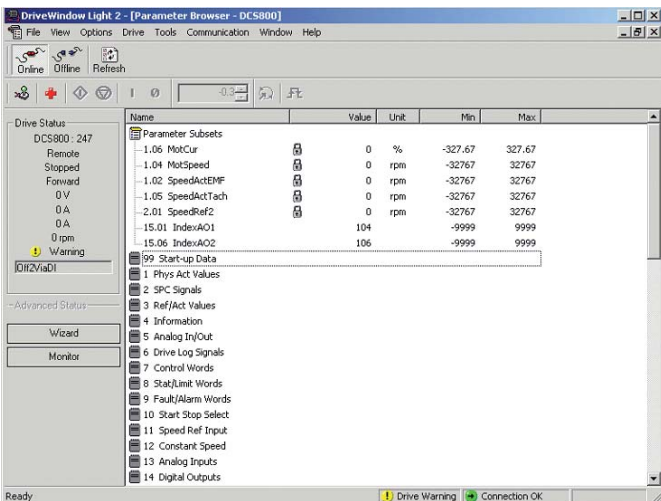

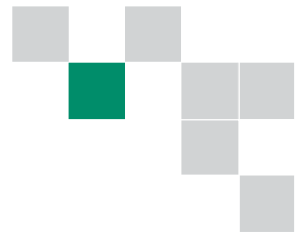

DWL Startup Assistant

DWL Startup Assistant for DCS800 gives important assistance for commissioning by interactive dialog. The commissioning steps are presented in correct sequence and necessary parameters are preselected.

The basic port collects basic motor and connection data and executes controller auto tunings.

The advanced port provides assistance for 12-pulse operation, field reversal, serial communication (field-bus) and master-follower configuration.

A context-sensitive help function is present during the whole sequence.

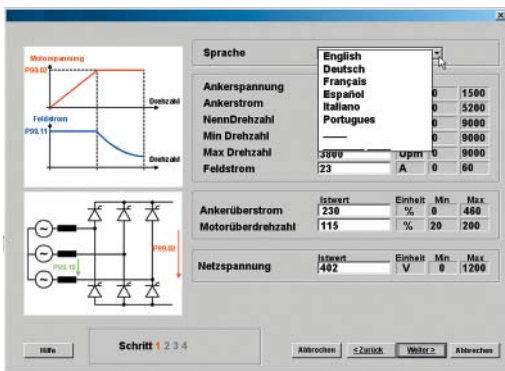

One page is freely configurable by the user. An individual commissioning sequence or parameter selection can be setup to application, machine or motor demands.

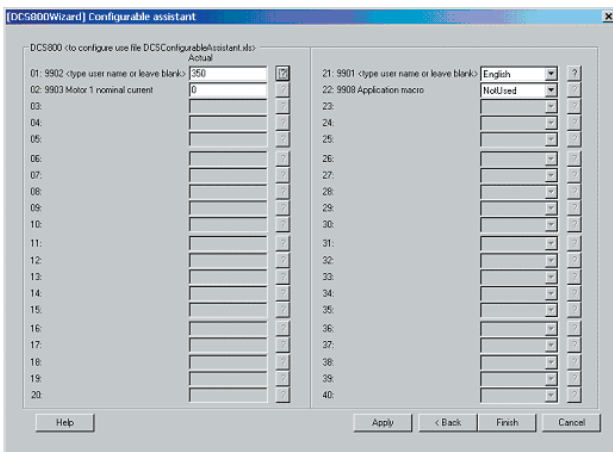

DWL AP Tool

DWL AP is a graphical PC tool to create, document, edit and download Adaptive Programs. DWL AP supports Adaptive Programming of DCS800. Adaptive Program contains 16 function blocks and is available in standard firmware. DWL AP offers a clear and easy way to develop, test and document these programs with a PC.

It is a user-friendly tool to modify function blocks and their connections. No special programming skills are required, basic knowledge about block programming is sufficient.

Adaptive Programs are easy to document as hard copies or store as PC files. All related information is saved directly to the drive by parameter.

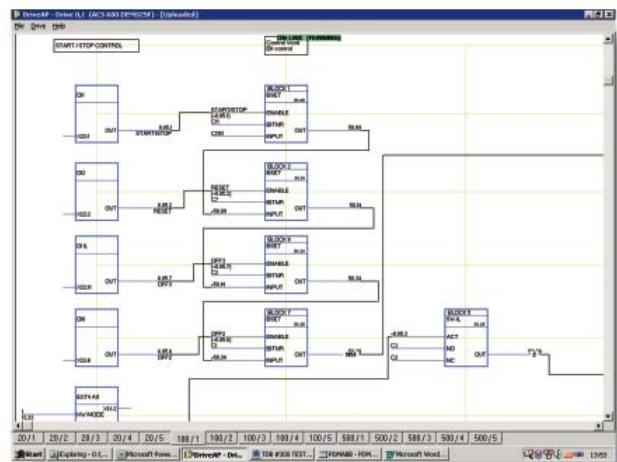

Startup, maintenance and integration

DriveOPC

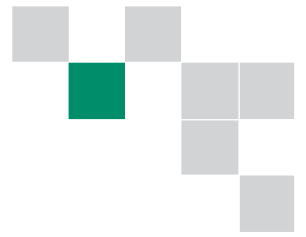

Integration tool

DriveOPC is a software package which allows OLE for Process Control (OPC) communication between Windows applications and DCS800 DC Drives. It allows Object Linking and Embedding (OLE) for Process Control (OPC) communication. This OPC server is an ideal tool for integrating DCS800 DC Drives and commercial PC software and creating PC based controlling and monitoring systems.

Remote monitoring

DriveOPC enables remote connection via LAN (local area networks). The remote PC can be connected by its IP address (e.g. "164.12.43.33") or by the DNS name (e.g. "Gitas213").

OPC based software

OPC is an industry standard created in cooperation with Microsoft. It is an open architecture interface design, managed by the international OPC foundation. OPC is meant for different kinds of factory automation.



DriveOPC is based on OPC foundation data access standard 1.0A and Microsoft COM/DCOM technology. DriveOPC has full access to all drives, even when remote connection via LAN is used.

High speed communication

DriveOPC uses a high-speed fibre optic cable network with DDCS communication protocol. This makes communication between PC and drives very fast. The fibre optic network is safe and extremely immune against external disturbance. The fibre optic communication card is needed inside the computer.

DriveOPC features

DriveOPC supports OPC's data access 1.0A.

Read access to:

- Drive status: local, running, direction, fault, warning, reference
- Signals and parameters
- Fault logger contents
- Event logger contents
- General drive information
- Data logger settings, status and contents

Write access to:

- Drive Control: local, start, stop, forward, reverse, coast stop, reset fault, home, teach-in, contactor on/off, reference
- Parameters
- Fault logger clear
- Data logger init, start, trig, clear

Remote monitoring tool

Ethernet module

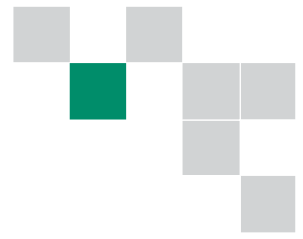

Browser-based, user-friendly

The intelligent Ethernet NETA-01 module gives simple access to the drive by means of the Internet communicating via a standard web browser. The user can set up a virtual monitoring room wherever there is a PC with an Internet connection or via a simple dial-up modem connection. This enables remote monitoring, configuration, diagnostics and, when needed, control. The drive can also provide process related information, such as load level, run time, energy consumption and I/O data, the bearing temperature of the driven machine, for instance.

This opens new possibilities for the monitoring and maintenance of unmanned applications across a range of industries, for instance water, wind power, building services and oil & gas, as well as any application where the user needs access to the drives from more than one location. It also provides an opportunity for OEMs and system integrators to support their installed base globally.

No PC needed at local end

The intelligent Ethernet module has an embedded server with the necessary software for the user interface, communication and data storage. This gives ease of access, realtime information and the possibility for two-way communication with the drive, enabling immediate response and actions, saving time and money. This is possible without using a PC at the local end, as required by other remote solutions.

Powerful and versatile

Up to nine drives can be connected to the intelligent Ethernet module via fibre optic links. It is available as an option for new drives, as well as an upgrade for existing systems. Access to the module is secured by user ID and passwords.

It connects to the drive with fibre optic cables. The size of the module is 93 (h) x 35 (w) x 76.5 (d) mm.

The web page of the module is opened like any other web address. The home page shows a general overview of the system with traffic lights and action buttons to guide the user through the different sections.

Features

- Virtual monitoring room for
 - Monitoring
 - Configuration of parameters
 - Diagnostics
 - Control, if needed
- Browser based access via
 - Intra-/extra-/Internet or
 - Simple dial-up modem connection
- No PC needed at the local end
- Can be used as a Modbus/TCP bridge for control purposes



Service products



To reduce the total cost of owning ABB drives and to maximize their availability ABB offers the following services:

Training services

ABB offers dedicated training on ABB drives for your service and operating personnel. Upon successful completion of the training course your personnel will have acquired the skills to use ABB drives correctly and safely, and also to get the best results from their application.

Service product code	Service type	Description
G560	DCS800 - 3 days	Basic training
G561	DCS800 - 1 day	Startup & Service Hands-on

ABB has a service organization that spans the globe. Contact your local ABB sales office for more information about our services.

www.abb.com/abbuniversity

Spare part services

ABB offers a fast and effortless information and ordering system to facilitate spare part management. Parts OnLine is at your service 24 hours.

<http://www.abb.com/partsonline>

Startup services

Using ABB's startup services you can trust that your drives are correctly commissioned and well-tuned to their application. ABB employs authorized professionals who have been thoroughly trained for their job.

ABB maintenance services

ABB maintenance services ensure optimal operation of your drives and extend their useful life.



DCS800 family



DCS800-S Modules

The versatile drive for any application

20 ... 5,200 A_{DC}
0 ... 1,160 V_{DC}
230 ... 1,000 V_{AC}
IP00

- Compact
- Highest power ability
- Simple operation
- Comfortable assistants, e.g. for commissioning or fault tracing
- Scalable to all applications
- Free programmable by means of integrated IEC61131-PLC



DCS800-A Enclosed Converters

Complete drive solutions

20 ... 20,000 A_{DC}
0 ... 1,500 V_{DC}
230 ... 1,200 V_{AC}
IP21 – IP54

- Individually adaptable to customer requirements
- User-defined accessories like external PLC or automation systems can be included
- High power solutions in 6- und 12-pulse up to 20,000 A, 1,500 V
- In accordance to usual standards
- Individually factory load tested
- Detailed documentation



DCS800-E Series

Pre-assembled drive-kits

20 ... 2,000 A_{DC}
0 ... 700 V_{DC}
230 ... 600 V_{AC}
IP00

- DCS800 Module with all necessary accessories mounted and fully cabled on a panel
- Very fast installation and commissioning
- Squeezes shut-down-times in revamp projects to a minimum
- Fits into Rittal cabinets
- Compact Version up to 450 A and Vario Version up to 2,000 A



DCS800-R Rebuild Kit

Digital control-kit for existing powerstacks

20 ... 20,000 A_{DC}
0 ... 1,160 V_{DC}
230 ... 1,200 V_{AC}
IP00

- Proven long life components are re-used, such as power stacks, (main) contactors, cabinets and cabling / busbars, cooling systems
- Use of up-to-date communication facilities
- Increase of production and quality
- Very cost-effective solution
- Open Rebuild Kits for nearly all existing DC-drives
- tailor-made solutions for...
 - BBC PxD
 - BBC SZxD
 - ASEA Tyrak
 - other manufacturers



ABB Automation Products
Wallstadter Straße
68526 Ladenburg • GERMANY

Phone +49(0)6203-71-70
Fax +49(0)6203-71-7609
www.abb.com/motors&drives
dc-drives@de.abb.com