



DC SCR DRIVE

SERIES 19H

Digital DC SCR Control

Installation & Operating Manual

Table of Contents

Section 1	
General Information	1-1
Overview	1-1
Limited Warranty	1-2
Safety Notice	1-3
Section 2	
Receiving & Installation	2-1
Receiving & Inspection	2-1
Physical Location	2-1
Optional Remote Keypad Installation	2-2
Control Installation	2-3
Installation Considerations	2-3
Line Impedance	2-3
Wiring Considerations	2-4
Isolation Transformer Sizing	2-5
Connections to an AC Generator Power Source	2-5
Wire Sizes and Protective Devices	2-6
AC Line and Motor Connections	2-8
Cooling Fan Connection	2-8
M Contactor Wiring	2-10
External Trip Input	2-11
Encoder Installation	2-12
Home (Orient) Switch Input	2-14
Buffered Encoder Output	2-14
Control Circuit Connections	2-15
Keypad Mode Connections	2-16
Standard Run 3 Wire Mode Connections	2-18
15 Speed 2-Wire Mode Connections	2-20
Bipolar Speed and Torque Mode Connections	2-22
Process Mode Connections	2-24
Specific Process Mode Outputs	2-26
Analog Inputs and Outputs	2-28
Analog Inputs	2-28
Analog Outputs	2-29
Opto-Isolated Inputs	2-30
Opto-Isolated Outputs	2-31
Reversing Contactor	2-32
Pre-Operation Checklist	2-33
Power-Up Procedure	2-34

Section 3	
Programming and Operation	3-1
Overview	3-1
Display Mode	3-2
Adjusting Display Contrast	3-2
Display Mode Screens	3-3
Display Screens & Diagnostic Information Access	3-4
Fault Log Access	3-5
Program Mode	3-6
Parameter Blocks Access for Programming	3-6
Changing Parameter Values when Security Code Not Used	3-7
Reset Parameters to Factory Settings	3-8
Initialize New Firmware	3-9
Parameter Definitions	3-10
Section 4	
Troubleshooting	4-1
No Keypad Display - Display Contrast Adjustment	4-1
How to Access the Fault Log	4-2
How to Clear the Fault Log	4-2
How to Access Diagnostic Information	4-3
Electrical Noise Considerations	4-9
Causes and Cures	4-9
Special Drive Situations	4-12
Drive Power Lines	4-12
Radio Transmitters	4-12
Control Enclosures	4-13
Special Motor Considerations	4-13
Wiring Practices	4-14
Optical Isolation	4-15
Plant Ground	4-15

Section 5	
Specifications and Product Data	5-1
Specifications	5-1
Operating Conditions	5-1
Keypad Display	5-2
Control Specifications	5-2
Field Power Supply	5-3
Differential Analog Input	5-3
Analog Outputs	5-3
Digital Inputs	5-4
Digital Outputs	5-4
Diagnostic Indications	5-4
Dimensions	5-7
Appendix A	A-1
Field Supply Module	A-1
Appendix B	B-1
Parameter Values	B-1
Appendix C	C-1
Remote Keypad Mounting Template	C-2



Section 1

General Information

Overview

The Baldor Series 19H control is a three phase, full wave, uni-directional DC motor armature and field (where applicable) control. The SCR bridge converts three phase AC power to controlled DC to operate the DC motor armature. The AC input is also used for the reference transformer input to operate power supplies and synchronize to the AC input line. The firing pulses are supplied to the SCR gates through the pulse amplifiers and transformers. This control is of the NEMA Type C designation.

The Baldor Series 19H control may also be used with permanent magnet field motors and DC spindle drive motors. In addition, the Baldor Series 19H control may be used with standard feedback from armature or encoder. Tachometer or resolver feedback is available with optional expansion boards.

The Baldor Series 19H control may be used in many different applications. It can be configured to operate in a number of modes depending upon the application requirements and user preference.

It is the responsibility of the user to determine the correct operating mode to use for the application. These choices are made using the keypad as explained in Section 3 of this manual.

Limited Warranty

For a period of two (2) years from the date of original purchase, BALDOR will repair or replace without charge controls and accessories which our examination proves to be defective in material or workmanship. This warranty is valid if the unit has not been tampered with by unauthorized persons, misused, abused, or improperly installed and has been used in accordance with the instructions and/or ratings supplied. This warranty is in lieu of any other warranty or guarantee expressed or implied. BALDOR shall not be held responsible for any expense (including installation and removal), inconvenience, or consequential damage, including injury to any person or property caused by items of our manufacture or sale. (Some states do not allow exclusion or limitation of incidental or consequential damages, so the above exclusion may not apply.) In any event, BALDOR's total liability, under all circumstances, shall not exceed the full purchase price of the control. Claims for purchase price refunds, repairs, or replacements must be referred to BALDOR with all pertinent data as to the defect, the date purchased, the task performed by the control, and the problem encountered. No liability is assumed for expendable items such as fuses.

Goods may be returned only with written notification including a BALDOR Return Authorization Number and any return shipments must be prepaid.

Safety Notice

This equipment contains voltages that may be as high as 600 volts! Electrical shock can cause serious or fatal injury. Only qualified personnel should attempt the start-up procedure or troubleshoot this equipment.

This equipment may be connected to other machines that have rotating parts or parts that are driven by this equipment. Improper use can cause serious or fatal injury. Only qualified personnel should attempt the start-up procedure or troubleshoot this equipment.

PRECAUTIONS

- ⚠ WARNING:** Do not touch any circuit board, power device or electrical connection before you first ensure that power has been disconnected and there is no high voltage present from this equipment or other equipment to which it is connected. Electrical shock can cause serious or fatal injury. Only qualified personnel should attempt the start-up procedure or troubleshoot this equipment.
- ⚠ WARNING:** This unit has an automatic restart feature that will start the motor whenever input power is applied and a RUN (FWD or REV) command is issued. If an automatic restart of the motor could cause injury to personnel, the automatic restart feature should be disabled by changing the Level 2 Miscellaneous block, Restart Auto/Man parameter to Manual.
- ⚠ WARNING:** Be sure that you are completely familiar with the safe operation of this equipment. This equipment may be connected to other machines that have rotating parts or parts that are controlled by this equipment. Improper use can cause serious or fatal injury. Only qualified personnel should attempt the start-up procedure or troubleshoot this equipment.
- ⚠ WARNING:** Be sure the system is properly grounded before applying power. Do not apply AC power before you ensure that all grounding instructions have been followed. Electrical shock can cause serious or fatal injury.
- ⚠ WARNING:** Do not remove cover for at least five (5) minutes after AC power is disconnected to allow capacitors to discharge. Dangerous voltages are present inside the equipment. Electrical shock can cause serious or fatal injury.
- ⚠ WARNING:** Improper operation of control may cause violent motion of the motor shaft and driven equipment. Be certain that unexpected motor shaft movement will not cause injury to personnel or damage to equipment. Certain failure modes of the control can produce peak torque of several times the rated motor torque.
- ⚠ WARNING:** Motor circuit may have high voltage present whenever AC power is applied, even when motor is not rotating. Electrical shock can cause serious or fatal injury.

Continued on next page

⚠ Caution: Over-current protection is required by the National Electrical Code. The installer of this equipment is responsible for complying with the National Electrical Code and any applicable local codes which govern such practices as wiring protection, grounding, disconnects, and other current protection.

⚠ Caution: Suitable For Use An A Circuit Capable of Delivering Not More Than the rms Symmetrical Amperes listed here at 600VAC maximum.

<u>Horsepower</u>	<u>rms Symmetrical Amperes</u>
1-50	5,000
51-200	10,000
201-400	18,000
401-600	30,000
601-900	42,000

⚠ Caution: Do not supply any power to the External Trip input at J1-16 and 17. Power on these leads can damage the control. Use a dry contact type that requires no external power to operate.

⚠ Caution: Do not use power factor correction capacitors on the input power lines to the control or damage to the control may result.

⚠ Caution: Do not install capacitors across the A1/A2 armature terminals or SCR failure may result.

⚠ Caution: Disconnect motor leads (A1 and A2) from control before you perform a “Megger” test on the motor. Failure to disconnect motor from the control will result in extensive damage to the control. The control is tested at the factory for high voltage / leakage resistance as part of Underwriter Laboratory requirements.

Section 2 Receiving & Installation

Receiving & Inspection

The Series 19H DC SCR Control is thoroughly tested at the factory and carefully packaged for shipment. When you receive your control, there are several things you should do immediately.

1. Observe the condition of the shipping container and report any damage immediately to the commercial carrier that delivered your control.
2. Verify that the part number of the control you received is the same as the part number listed on your purchase order.
3. If the control is to be stored for several weeks before use, be sure that it is stored in a location that conforms to published storage specifications. (Refer to Section 5 of this manual).

Physical Location

The location of the 19H is important. It should be installed in an area that is protected from direct sunlight, corrosives, harmful gases or liquids, dust, metallic particles, and vibration. Exposure to these elements can reduce the operating life and degrade performance of the control.

Several other factors should be carefully evaluated when selecting a location for installation:

1. For effective cooling and maintenance, the control should be mounted vertically on a flat, smooth, non-flammable vertical surface. When the control is mounted in an enclosure, use the watts loss information of Table 2-1 to provide proper cooling and ventilation (4 watts per continuous output ampere).
2. At least two inches clearance must be provided on all sides for air flow.
3. Front access must be provided to allow the control cover to be opened or removed for service and to allow viewing of the Keypad Display. (The keypad may optionally be remote mounted up to 100 feet from the control.)
Controls installed in a floor mounted enclosure must be positioned with clearance to open the enclosure door. This clearance will also provide sufficient air space for cooling.
4. **Altitude derating.** Up to 3300 feet (1000 meters) no derating required. Above 3300 ft, derate the continuous and peak output current by 2% for each 1000 ft.
5. **Temperature derating.** Up to 40°C no derating required. Above 40°C, derate the continuous and peak output current by 2% per °C. Maximum ambient is 55°C.

Shock Mounting

If the control will be subjected to levels of shock greater than 1G or vibration greater than 0.5G at 10 to 60Hz, the control should be shock mounted. Excessive vibration within the control could cause internal connections to loosen and cause component failure or electrical shock hazard.

Table 2-1 Series 19H Watts Loss Ratings (4 Watts per Amp)

Catalog No.	Rated Current	Watts Loss	Catalog No.	Rated Current	Watts Loss
BC19H205-CO	20	80	BC19H410-CO	20	80
BC19H210-CO	40	160	BC19H420-CO	40	160
BC19H215-CO	60	240	BC19H430-CO	60	240
BC19H220-CO	75	300	BC19H440-CO	75	300
BC19H225-CO	100	400	BC19H450-CO	100	400
BC19H240-CO	140	560	BC19H475-CO	140	560
BC19H250-CO	180	720	BC19H4100-CO	180	720
BC19H260-CO	210	840	BC19H4125-CO	210	840
BC19H275-CO	270	1080	BC19H4150-CO	270	1080
			BC19H4200-CO	350	1400
			BC19H4250-CO	420	1680
			BC19H4300-CO	500	2000

Optional Remote Keypad Installation The keypad may be remotely mounted using the optional Baldor keypad extension cable. The keypad assembly (white - DC00005A-01; grey - DC00005A-02) comes complete with the screws and gasket required to mount it to an enclosure. When the keypad is properly mounted to a NEMA Type 4X indoor enclosure, it retains the Type 4X indoor rating.

Tools Required:

- Center punch, tap handle, screwdrivers (Phillips and straight) and crescent wrench.
- 8-32 tap and #29 drill bit (for tapped mounting holes) or #19 drill (for clearance mounting holes).
- 1-1/4" standard knockout punch (1-11/16" nominal diameter).
- RTV sealant.
- (4) 8-32 nuts and lock washers.
- Extended 8-32 screws (socket fillister) are required if the mounting surface is thicker than 12 gauge and is not tapped (clearance mounting holes).
- Remote keypad mounting template. A tear out copy is provided at the end of this manual for your convenience.

Mounting Instructions: For tapped mounting holes

1. Locate a flat 4" wide x 5.5" minimum high mounting surface. Material should be sufficient thickness (14 gauge minimum).
2. Place the template on the mounting surface or mark the holes as shown.
3. Accurately center punch the 4 mounting holes (marked A) and the large knockout (marked B).
4. Drill four #29 mounting holes (A). Thread each hole using an 8-32 tap.
5. Locate the 1-1/4" knockout center (B) and punch using the manufacturers instructions.
6. Debur knockout and mounting holes making sure the panel stays clean and flat.
7. Apply RTV to the 4 holes marked (A).
8. Assemble the keypad to the panel. Use 8-32 screws, nuts and lock washers.
9. From the inside of the panel, apply RTV over each of the four mounting screws and nuts. Cover a 3/4" area around each screw while making sure to completely encapsulate the nut and washer.

Mounting Instructions: For clearance mounting holes

1. Locate a flat 4" wide x 5.5" minimum high mounting surface. Material should be sufficient thickness (14 gauge minimum).
2. Place the template on the mounting surface or mark the holes as shown on the template.
3. Accurately center punch the 4 mounting holes (marked A) and the large knockout (marked B).
4. Drill four #19 clearance holes (A).
5. Locate the 1-1/4" knockout center (B) and punch using the manufacturers instructions.
6. Debur knockout and mounting holes making sure the panel stays clean and flat.
7. Apply RTV to the 4 holes marked (A).
8. Assemble the keypad to the panel. Use 8-32 screws, nuts and lock washers.
9. From the inside of the panel, apply RTV over each of the four mounting screws and nuts. Cover a 3/4" area around each screw while making sure to completely encapsulate the nut and washer.

Control Installation

The control must be securely fastened to the mounting surface. Use the four (4) mounting holes to fasten the control to the mounting surface or enclosure. Refer to Section 5 for mounting dimensions and mounting hole location.

Shock Mounting

If the control will be subjected to levels of vibration greater than 0.5G at 10 to 60Hz, the control should be shock mounted. Excessive vibration within the control could cause internal connections to loosen and cause component failure or electrical shock hazard.

Installation Considerations

Interconnection wiring is required between the DC SCR control, AC power source, motor, host control and any operator interface stations. Use listed closed loop connectors that are of appropriate size for wire gauge being used. Connectors are to be installed using crimp tool specified by the manufacturer of the connector. Only Class 1 wiring should be used.

Baldor Series 19H controls feature UL approved adjustable motor overload protection suitable for motors rated at no less than 50% of the output rating of the control. Other governing agencies such as NEC may require separate over-current protection. The installer of this equipment is responsible for complying with the National Electric Code and any applicable local codes which govern such practices as wiring protection, grounding, disconnects and other current protection.

Line Impedance

The Baldor Series 19H control requires a 5% maximum line impedance (voltage drop across the reactor is 5% when the control draws rated input current).

The input impedance of the power lines can be determined in two ways:

1. Measure the line to line voltage at no load and at full rated load. Use these measured values to calculate impedance as follows:
$$\% \text{Impedance} = \frac{(\text{Volts}_{\text{No Load}} - \text{Volts}_{\text{Full Load}})}{(\text{Volts}_{\text{No Load}})} \times 100$$
2. Calculate the short circuit current capacity of the power line. If the short circuit current capacity is greater than the published maximum short circuit current ratings for the control, a line reactor should be installed.

Two methods of calculating short circuit current capacity are provided:

A. Method 1

Calculate short circuit current as follows:

$$I_{SC} = \frac{(KVA_{XFMR} \times 1000 \times 100)}{(\%Z_{XFMR} \times V_{L-L} \times \sqrt{3})}$$

Example: 50KVA transformer with 2.75% impedance @ 460VAC

$$I_{SC} = \frac{(50 \times 1000 \times 100)}{(2.75 \times 460 \times \sqrt{3})} = 2282 \text{ Amps}$$

B. Method 2

Step 1: Calculate KVA short circuit as follows:

$$KVA_{SC} = \frac{(KVA_{XFMR})}{\left(\frac{\%Z_{XFMR}}{100}\right)} = \left(\frac{50}{.0275}\right) = 1818.2 \text{ KVA}$$

Step 2: Calculate short circuit current as follows:

$$I_{SC} = \frac{(KVA_{SC} \times 1000)}{(V_{L-L} \times \sqrt{3})} = \frac{1818.2 \times 1000}{460 \times \sqrt{3}} = 2282 \text{ Amps}$$

where:

KVA_{XFMR} = Transformer KVA

I_{SC} = short circuit current

Z_{XFMR} = Transformer Impedance

V_{L-L} = Input volts measured line to line.

Wiring Considerations

The DC control is self protected from normal AC line transients and surges. Additional external protection may be required if high energy transients are present on the incoming power source. These transients could be caused by sharing a power source with arc welding equipment, large motors being started across the line, or other industrial equipment requiring large surge currents. To prevent damage due to power source disturbances the following should be considered:

- a) Connect the control on a feeder line separate from those supplying large inductive loads.
- b) Supply power to the control through a suitably sized isolation transformer. When using an isolation transformer to power the control, always switch the power off and on between the transformer secondary and the control input to avoid spikes at the control when power is removed from the primary side.

All external signal wiring to the DC control should be run in a separate conduit from all other wiring. The use of shielded twisted pair wire is recommended for all signal wiring. The shield of the control wiring should be connected to analog ground of the DC control only. The other end of the shield should be taped to the wire jacket to prevent electrical shorts.

Wires for motor armature and fields may be run together in a conduit in accordance with NEC and local electrical codes and practices. For more information on wiring considerations, refer to "Electrical Noise Considerations" in Section 4 of this manual.

- ⚠ Caution: Separate over-current protection is required by the National Electrical Code. The installer of this equipment is responsible for complying with the National Electrical Code and any applicable local codes which govern such practices as wiring protection, grounding, disconnects, and other current protection.**
- ⚠ Caution: Do not use power factor correction capacitors on the input power lines to the control or damage to the control may result.**
- ⚠ Caution: Do not install capacitors across the A1/A2 armature terminals or SCR failure may result.**

Inter connection wiring is required between the DC control, AC power source, motor, host control, and any optional control stations. Use listed closed loop connectors sized for the wire gauge involved. Connectors are to be installed using the crimp tool specified by the connector manufacturer.

The Series 19H DC SCR control may require input power protection in the form of either a circuit breaker or fuses. All controls are equipped from Baldor Electric Company with three input fuses and one armature output fuse. Refer to Table 2.1 for fuse sizes.

Connect three phase AC power lines to the input power terminals L1, L2, and L3. The phase rotation of the input power is not important since the control is not sensitive to phase rotation of the input power.

Connect an earth ground to the control grounding lug (GRD) according to applicable local electrical codes. Motor ground and input power earth ground should be connected to the ground lug.

The use of a power disconnect is recommended between the input power and the control to provide a fail safe method to disconnect the control from the input power. The control will remain in a power up condition until all input power is removed from the control.

Isolation Transformer Sizing

Use the information in Table 2-2 to select the KVA rating of the transformer based on the HP rating of the control. The secondary voltage will be the input voltage to the control and the impedance should be 5% or less.

One exception to Table 2-2 is when the DC armature voltage is less than the AC input voltage. If this is the case, use the following formula:

$$KVA = 0.00163 \times VAC_{Secondary} \times IDC_{Secondary}$$

Table 2-2 Isolation Transformer KVA Selection

HP	5	7.5	10	15	20	25	30	40	50	60	75	100	125	150	200	250	300
KVA	7.5	11	14	20	27	34	40	51	63	75	93	118	145	175	220	275	330

Connections to an AC Generator Power Source

If a motor driven generator set is to be used as the AC power source for the Baldor Control, the KVA rating of the generator should be at least 20 times the KVA rating of the control.

Wire Sizes and Protective Devices

Table 2-3 Recommended Wire Size – 230VAC

Catalog Number	Input Amp	Maximum Output		Fuse		Wire Size					
		HP	KW	Armature & AC Input	Buss Type	Armature Input		Field Power Supply		Field Power Output	
						AWG	MM ²	AWG	MM ²	AWG	MM ²
BC19H205-CO	16	5	3.7	50A, 500V	FWH-50A	10	6	14	2.5	10	6
BC19H210-CO	33	10	7.5	80A, 500V	FWH-80A	6	16	14	2.5	6	16
BC19H215-CO	49	15	11.2	100A, 500V	FWH-100A	4	25	14	2.5	3	30
BC19H220-CO	62	20	14.9	150A, 500V	FWH-150A	3	30	14	2.5	2	35
BC19H225-CO	82	25	18.6	150A, 500V	FWH-150A	1	50	14	2.5	1/0	54
BC19H240-CO	115	40	29.8	300A, 500V	FWH-300A	1/0	54	14	2.5	2/0	70
BC19H250-CO	148	50	37.3	350A, 500V	FWH-350A	3/0	95	14	2.5	4/0	120
BC19H260-CO	172	60	44.8	400A, 500V	FWH-400A	4/0	120	14	2.5	300MCM	150
BC19H275-CO	221	75	56	450A, 500V	FWH-450A	300MCM	150	14	2.5	500MCM	240

Table 2-4 Recommended Wire Size – 460VAC

Catalog Number	Input Amp	Maximum Output		Fuse		Wire Size					
		HP	KW	Armature & AC Input	Buss Type	Armature Input		Field Power Supply		Armature Output	
						AWG	MM ²	AWG	MM ²	AWG	MM ²
BC19H410-CO	16	10	7.5	50A, 700V	FWP-50A	10	6	14	2.5	10	6
BC19H420-CO	33	20	14.9	80A, 700V	FWP-80A	6	16	14	2.5	6	16
BC19H430-CO	49	30	22.4	100A, 700V	FWP-100A	4	25	14	2.5	3	30
BC19H440-CO	62	40	29.8	150A, 700V	FWP-150A	3	30	14	2.5	2	35
BC19H450-CO	82	50	37.3	150A, 700V	FWP-150A	1	50	14	2.5	1/0	54
BC19H475-CO	115	75	56	300A, 700V	FWP-300A	1/0	54	14	2.5	2/0	70
BC19H4100-CO	148	100	74.6	350A, 700V	FWP-350A	3/0	95	14	2.5	4/0	120
BC19H4125-CO	172	125	93	400A, 700V	FWP-400A	4/0	120	14	2.5	300MCM	150
BC19H4150-CO	221	150	112	400A, 700V	FWP-400A	300MCM	150	14	2.5	500MCM	240
BC19H4200-CO	287	200	149	400A, 700V	FWP-400A	300MCM	150	14	2.5	500MCM	240
BC19H4250-CO	344	250	187	600A, 700V	FWP-600A	(2) 300MCM	150	14	2.5	(2) 400MCM	200
BC19H4300-CO	418	300	224	800A, 700V	FWP-800A	(2) 400MCM	200	14	2.5	(2) 500MCM	240

Note: All wire sizes based on 75°C copper wire, 40°C ambient temperature, 4-6 conductors per conduit or raceway except as noted.

Note: Wire sizes shown above are for normal length power runs. Voltage drop to the motor and control should be considered. For longer power runs, use heavier gauge copper wire (within the size of the wire terminals).

Table 2-5 Other Fuses

Armature Input Wire (Copper)	Field Power Output Wire (Copper)
Standard Field Power Supply (15A)	Buss KTK 20
High Capacity Field Power Supply (40A)	Baldor V4360050 (Gould A70Q50)
Reference/Supply Fuses	Buss FNQ 15/100

Figure 2-1 19H Enclosure Component Locations

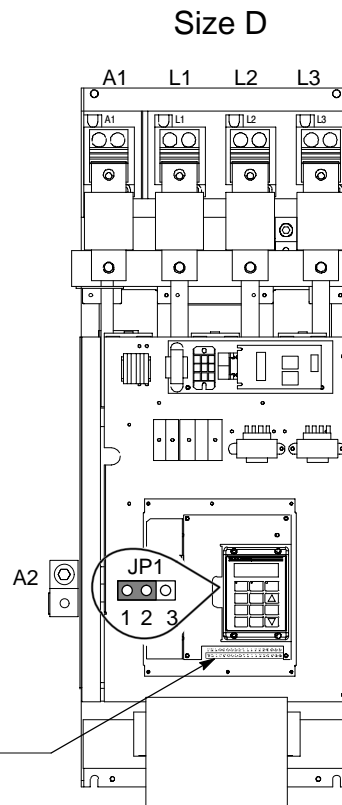
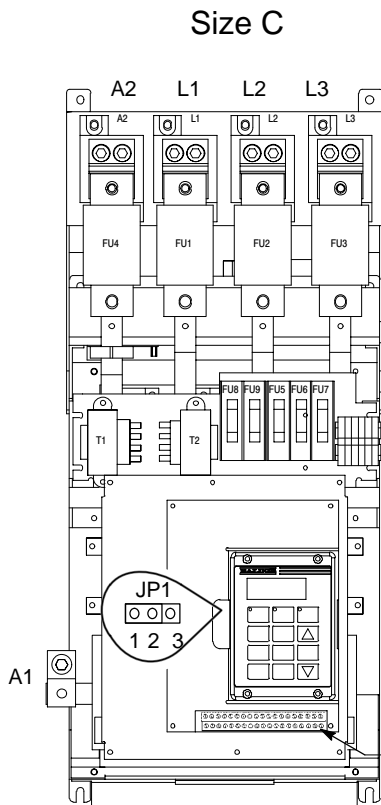
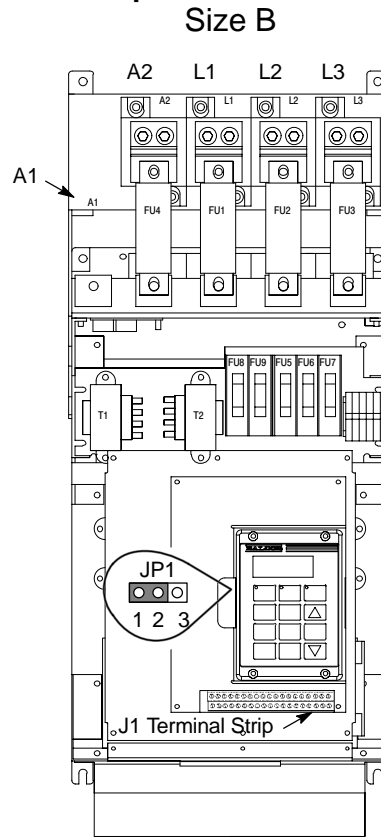
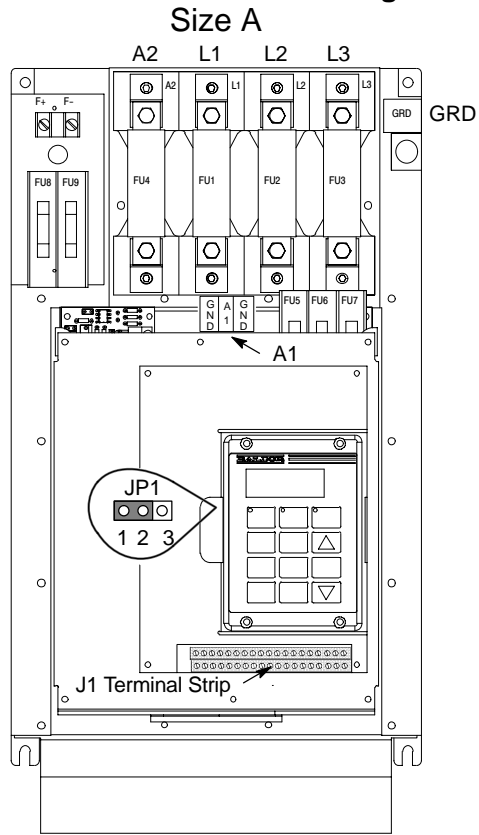

AC Line and Motor Connections

Be sure all power to the control is disconnected before proceeding.

The AC power and motor connections are shown in Figure 2-3. Be sure to comply with all applicable codes.

1. Connect the incoming AC power wires to L1, L2 and L3 at the Main Circuit Terminals. The phase rotation is not important as the control is not phase sensitive.
 2. * Connect earth ground to the GRD terminal of the control.
 3. Connect the armature leads of the DC motor to control terminals A1 and A2. A motor circuit contactor is recommended to provide a positive disconnect of the motor armature.
 4. * Connect motor ground wire to the GRD terminal of the control.
 5. ** Connect the field power supply leads of the DC motor to control terminals F+ and F-. The standard field supply provides up to 85% of the line voltage as its DC output voltage @ 15 amperes. A high capacity field power supply provides up to 85% of the line voltage as its DC output voltage @ 40 amperes.
- * Grounding by using conduit or panel connection is not adequate. A separate conductor of the proper size must be used as a ground conductor.
- ** If your motor requires more than 85% of the line voltage as its DC input voltage, a step up transformer is required. This is added between the incoming line terminals and the L1 and L2 terminals of the field supply module. This connection is phase sensitive with main input L1 and L2. The maximum input voltage to the field supply module is 528VAC @ 60Hz.

Note: The 19H control may be connected to a permanent magnet field DC motor. In this case, the field supply is not connected, the Level 2 Motor Data block, Motor Field parameter is set to PERM MAGNET, and the Level 1 Field Control block, Field PWR Supply parameter is set to NONE.

Cooling Fan Connection Some controls are equipped with cooling fans (pancake fans) or centrifugal blowers which must be connected to single phase power. 230VAC controls have 230VAC single phase rated fans and 460VAC controls have 115VAC rated fans. Refer to the rating plate located near the fan for voltage identification. Connect the proper single phase power to the two fan terminals located on the side of the fan.

D size controls have a centrifugal blower that may be connected to either 230 or 460 volt AC single phase power. Connect the 230VAC or 460VAC to the blower as shown in Figure 2-2. The terminal block is located on the blower.

Figure 2-2 230VAC/460VAC Blower Connections (Single Phase)

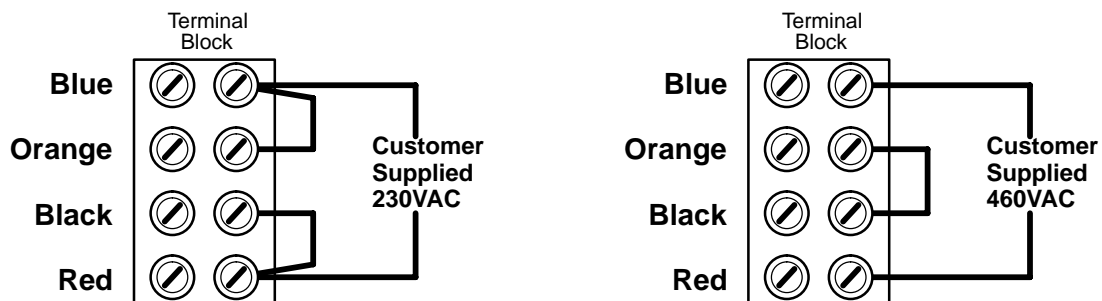

Armature Connection

Connect the two armature power leads of the DC motor to terminals A1 and A2 of the control power terminal strip, see Figure 2-3. Refer to Figure 2-1 for the location of the A1 and A2 terminals.

Field Supply Connection (Shunt Wound Motors)

Connect the two field power leads of the DC motor to terminals F+ and F– of the control power terminal strip. Refer to Section 5 of this manual for the specific location of the F+ and F– terminals.

Note: The Baldor Series 19H control may be configured to be used with permanent magnet field motors. In this case the field power supply of the control is not used.

The standard field supply is capable of supplying 15 amps maximum to the motor field. If more field current is required an optional external 40 amp maximum field supply is available from Baldor Electric Company.

The motor ground lead or case ground should be connected to the control ground lug. Connection of motor temperature sensor switch to the external trip input, J1–16, located on the J1 terminal strip is optional. The motor thermostat should be a dry contact (N.C.) type requiring no external power to operate. Ground both the chassis ground lug and motor frame to machine or earth ground. Use the same size wire used for the AC connections.

⚠ Caution: Voltage may be present at the motor whenever the control is receiving input power. Remove all power from the control before attempting any service of the motor.

Figure 2-3 3 Phase AC Power and Motor Connections

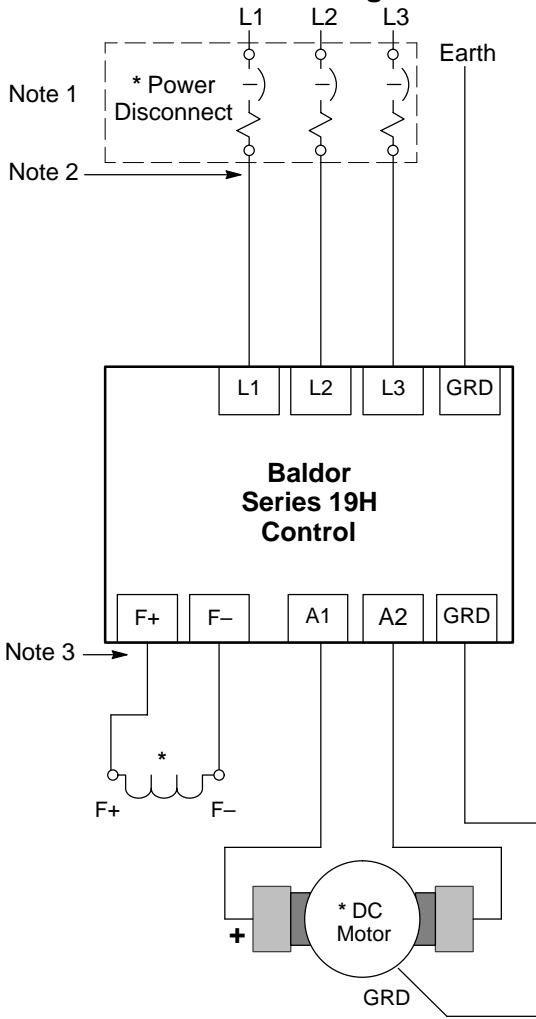

* Optional components not provided with 19H Control.

Notes:

1. See "Wire Sizes and Protective Devices" described previously in this section for information to size optional Power Disconnect.
2. Shield wires inside a metal conduit.
3. Metal conduit should be used to shield output wires (between control and motor). Connect conduits so the use of Load Reactor or RC Device does not interrupt EMI/RFI shielding.
4. A motor circuit contactor is recommended to provide a positive disconnect and prevent motor rotation which could pose a safety hazard. Connect the M-Contactor as shown. The contactor should open the enable input at J1-8 at least 20 msec before the main M-contacts open to prevent arcing at contacts. This greatly increases contactor life and allows use of IEC rated contactors.

Typical shunt wound motor field connection
120/240V or 150/300V. Consult manufacturers
specific motor data for details.

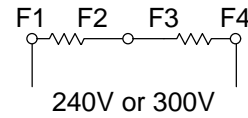
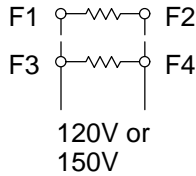

Optional Connection of M-Contactor

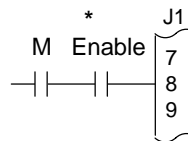
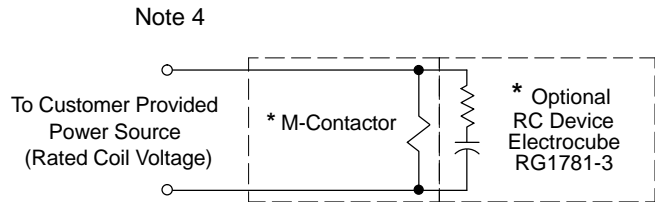
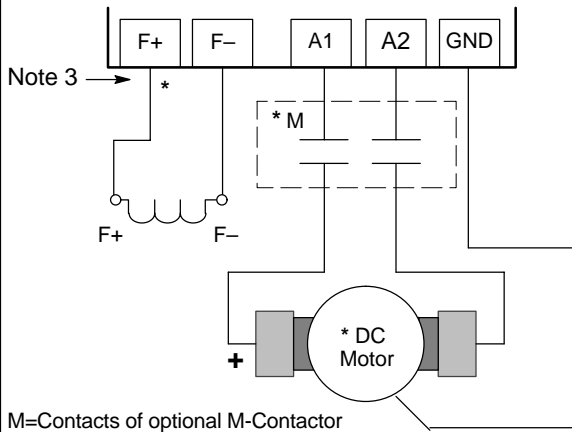

Note: Close "Enable" after "M" contact closure.

See Recommended Tightening Torques in Section 5.

M Contactor Wiring

Figure 2-3 shows how to connect an optional M Contactor. Control faults may occur if the control is enabled before the M Contactor is closed. The timing diagram shown in Figure 2-4 defines the correct operating sequence.

At Turn ON

Allow 20 milli seconds for the coil of the M contactor to energize and close the contactor before the Enable input at J1-8 is issued.

At Turn OFF

Do not allow the M Contactor to open until motor shaft rotation has stopped and the Enable at J1-8 has been removed. If this sequence does not occur, a TACH LOSS fault may be issued by the control.

Note: This example shows a "Drive ON" output to a PLC that is used to command the 19H control and the holding brake.

Figure 2-4 M Contactor Operation Sequence

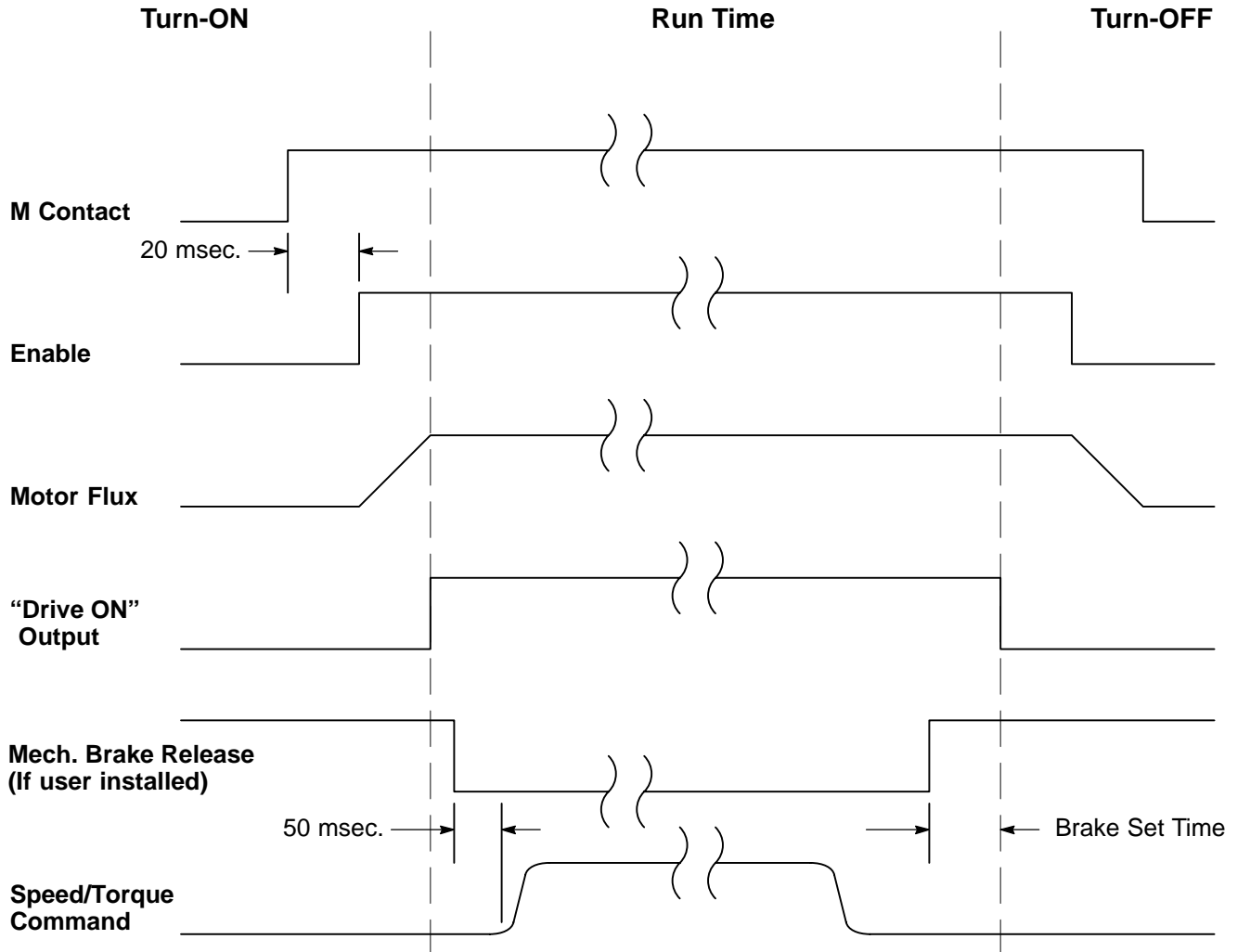

External Trip Input

Terminal J1-16 is available for connection to a normally closed thermostat or overload relay in all operating modes as shown in Figure 2-5. The thermostat contact should be a dry contact type with no power available from the contact. If the motor thermostat activates, the control will automatically disable and give an External Trip fault. When the motor cools sufficiently and the motor thermostat resets itself, the control may be restarted.

Connect the External Trip Input wires to J1-16 and J1-17. Do not place these wires in the same conduit as the motor power leads.

To activate the External Trip input, the Level 2 Protection block, External Trip parameter must be set to "ON".

Figure 2-5 Motor Temperature Relay

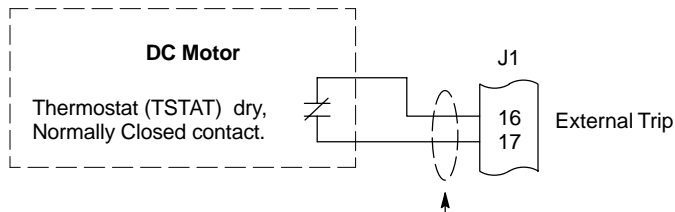

Do not run these wires in same conduit as motor leads or AC power wires.

Terminal tightening torque is 7 lb-in (0.8 Nm) maximum.

Encoder Installation

Electrical isolation of the encoder shaft and housing from the motor is required. Electrical isolation prevents capacitive coupling of motor noise that will corrupt the encoder signals. See electrical noise considerations in Section 4 of this manual.

Cable Preparation

Encoder wiring must be shielded twisted pairs, #22 AWG (0.34mm²) minimum size, 200' (60m) maximum, with an insulated overall shield.

Control End (See Figure 2-6.)

1. Strip the outside jacket approximately 0.375" (9.5mm) from the end.
2. Solder a #22 AWG (0.34mm²) wire to the braided shield.
3. Connect all shields to J1-30. To do this, solder a "Drain Wire" from each shield to the wire soldered to the braided shield in step 2.
4. Insulate or tape off ungrounded end of shields to prevent contact with other conductors or ground.

Encoder End

1. Strip the outside jacket approximately 0.375" (9.5mm) from the end.
2. Identify each of the four twisted pair and label or use the color codes shown in Figure 2-7 for the optional Baldor Encoder Cable.
3. Insulate or tape off ungrounded end of shields and unused conductors to prevent contact with other conductors or ground.

⚠ CAUTION: Do not connect any shields to the encoder case or motor frame. The encoder +5VDC supply at J1-29 is referenced to circuit board common. Do not connect any shields to ground or another power supply or damage to the control may result.

Figure 2-6 Encoder Cables

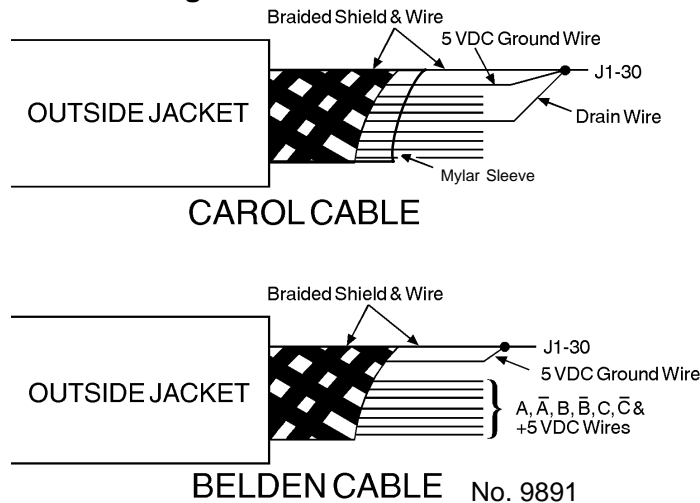
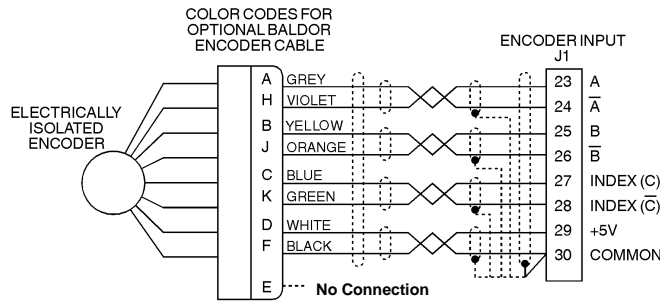

Figure 2-7 Encoder Connections



Terminal Tightening Torque = 7 Lb-in (0.8 Nm).

Encoder Cable Connection

Encoder cable must be separated by at least 3” (76mm) from parallel runs of power wires. Encoder cables that cross power wires must cross at a 90° angle only. Encoder wires must be #22 AWG (0.34mm²) minimum, 200 feet (60m) maximum length and must have an overall shield.

Note: Be careful not to pinch the wires’ insulation in J1 terminals as proper electrical connection may not be made.

1. Feed the control end of the cable through one of the “Knock-out” holes in the control case so connections can be made inside the control.

2. Differential Connections

Connect the cable braided shield to J1-30 at control end.

Connect the cable ends as follows: (See Figure 2-7.)

<u>Encoder End</u>	<u>Control End</u>
A	J1-23 (A)
H	J1-24 (A̅)
B	J1-25 (B)
J	J1-26 (B̅)
C	J1-27 Index(C)
K	J1-28 Index(C)
D	J1-29 (+5VDC)
F	J1-30 (Common)
E	No Connection

3. Single Ended Connections

Differential inputs are recommended for best noise immunity. If only single ended encoder signals are available, connect them to A, B, and INDEX (C) (J1-23, J1-25 and J1-27 respectively).

Home (Orient) Switch Input The Home or Orient function causes the motor shaft to rotate to a predefined home position. The home position is located when a machine mounted switch or the encoder "Index" pulse is activated (closed). Home is defined by a rising signal edge at terminal J1-27. The shaft will continue to rotate only in a CW direction for a user defined offset value. The offset is programmed in the Level 2 Miscellaneous Homing Offset parameter. The speed at which the motor will "Home" or orient is set with the Level 2 Miscellaneous Homing Speed parameter.

A machine mounted switch may be used to define the Home position in place of the encoder index channel. A differential line driver output from a solid state switch is preferred for best noise immunity. Connect this differential output to terminals J1-27 and J1-28.

A single ended solid-state switch or limit switch should be wired as shown in Figure 2-8. Regardless of the type of switch used, clean rising and falling edges at J1-27 are required for accurate positioning.

Note: Control requires dynamic brake hardware for Orient (Homing) function to work. Control will trip without dynamic brake hardware installed.

Figure 2-8 Typical Home or Orient Switch Connections

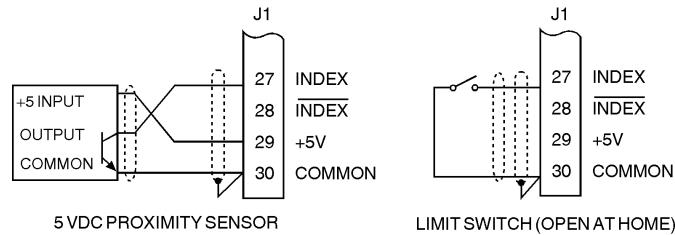

Terminal Tightening Torque = 7 Lb-in (0.8 Nm).

Buffered Encoder Output The control provides a buffered encoder output on pins J1-31 to J1-38 as shown in Figure 2-9. This output may be used by external hardware to monitor the encoder signals. It is recommended that this output only drive one output circuit load.

Figure 2-9 Buffered Encoder Output

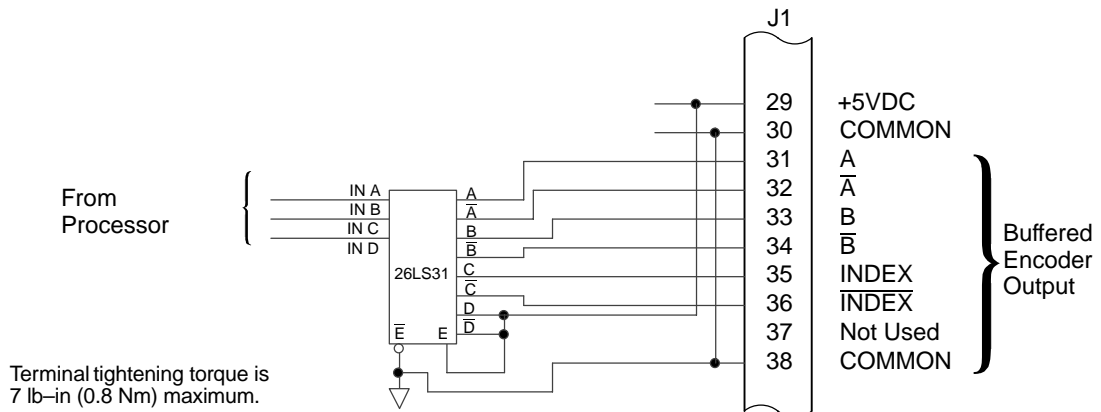

Control Circuit Connections Six different operating modes are available in the Series 19H DC SCR control. These operating modes define the basic motor control setup and the operation of the J1 input and output terminals (see Figure 2-1 for J1 location). After the circuit connections are completed, the operating mode is selected by programming the Operating Mode parameter in the Level 1 Input programming Block. Available operating modes include:

- Keypad Control
- Standard Run, 3 Wire Control
- 15 Speed, 2 Wire Control
- Bipolar Speed or Torque
- Process Control
- Serial

Note: The Serial operating mode requires one of the optional Serial Interface expansion boards (RS232 or 422/485). Installation and operation information for these serial expansion boards is provided in Serial Communications expansion board manual MN1310. This manual is shipped with the serial expansion boards.

Note: Bipolar hoist and 7 speed hoist may show as available Operating Mode parameters in the Series 19H software. Series 19H one-way controls should never be used for hoisting applications. Series 20H Line Regen controls should be used for hoisting and other overhauling load applications.

Keypad Mode Connections

To operate in the Keypad mode, set the Level 1 Input block, Operating Mode parameter to Keypad. In this mode, only the External Trip Opto Input at J1-16 is active (if the Level 2 Protection block, External Trip parameter is set to ON). Both analog outputs remain active. Connections are made as shown in Figure 2-10.

The STOP key can operate in either of two ways:

- Press STOP key one time to brake or coast to stop (as set in the Level 1 Keypad Setup block, Keypad Stop Mode parameter).
- Press STOP key two times to disable control.

Figure 2-10 Keypad Control Connection Diagram

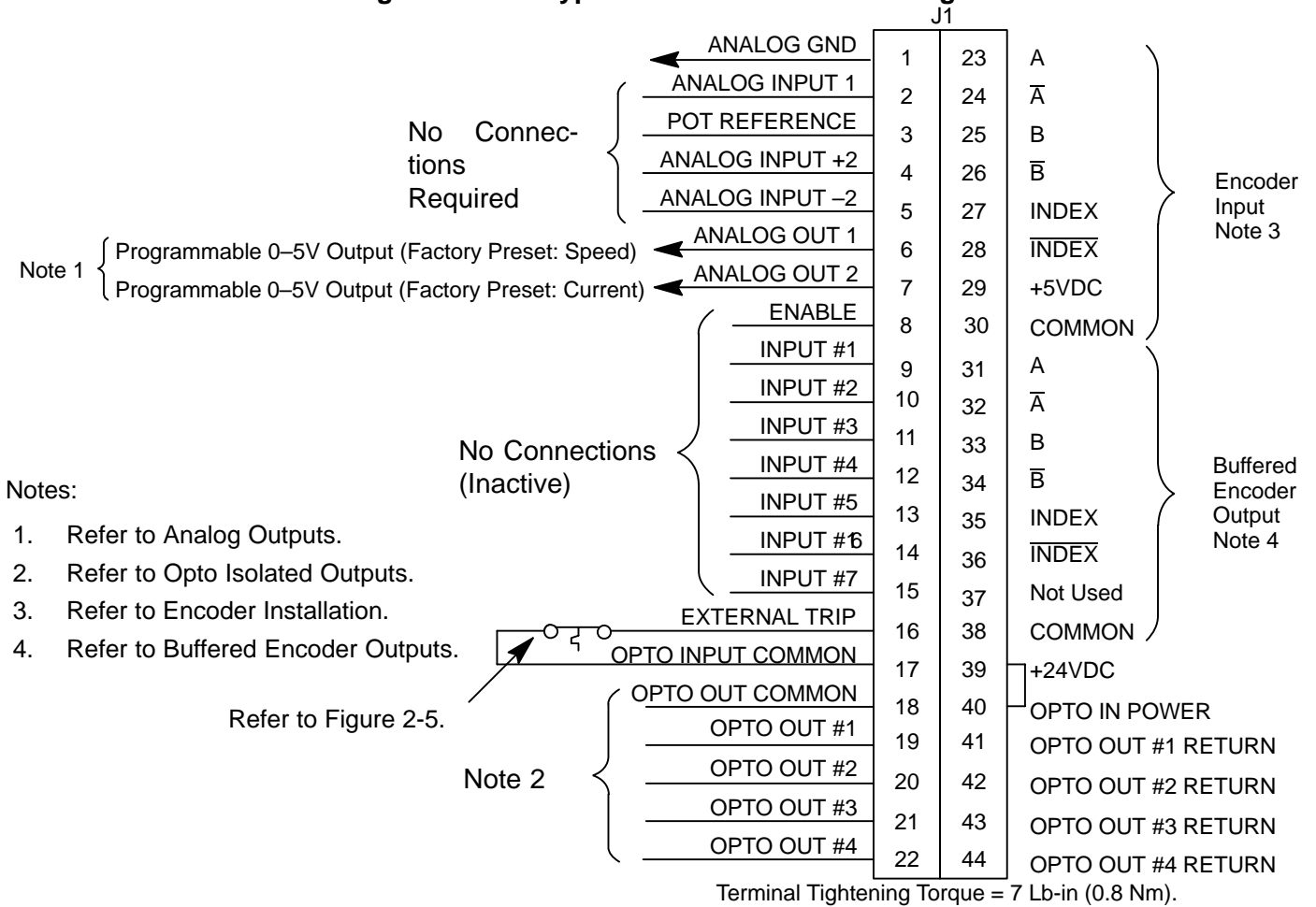

Note 1 { Programmable 0–5V Output (Factory Preset: Speed)
 Programmable 0–5V Output (Factory Preset: Current)

Notes:

1. Refer to Analog Outputs.
2. Refer to Opto Isolated Outputs.
3. Refer to Encoder Installation.
4. Refer to Buffered Encoder Outputs.

Refer to Figure 2-5.

- J1-16 OPEN causes an external trip to be received by control. The control will disable and display external trip when programmed "ON". When this occurs, the motor stop command is issued, drive operation is terminated and an external trip fault is displayed on the keypad display (also logged into the fault log).
 If J1-16 is connected, you must set Level 2 Protection block, External Trip to "ON".
- J1-39 & 40 Jumper as shown to power the Opto Outputs from the internal +24VDC supply.

Standard Run 3 Wire Mode Connections

In Standard Run mode, the control is operated by the opto Isolated inputs at J1-8 through J1-16 and the analog command input. The opto inputs can be switches as shown in Figure 2-11 or logic signals from another device. The External Trip opto input at J1-16 is active if connected as shown and the Level 2 Protection block, External Trip parameter is set to ON.

Figure 2-11 Standard Run 3-Wire Connection Diagram

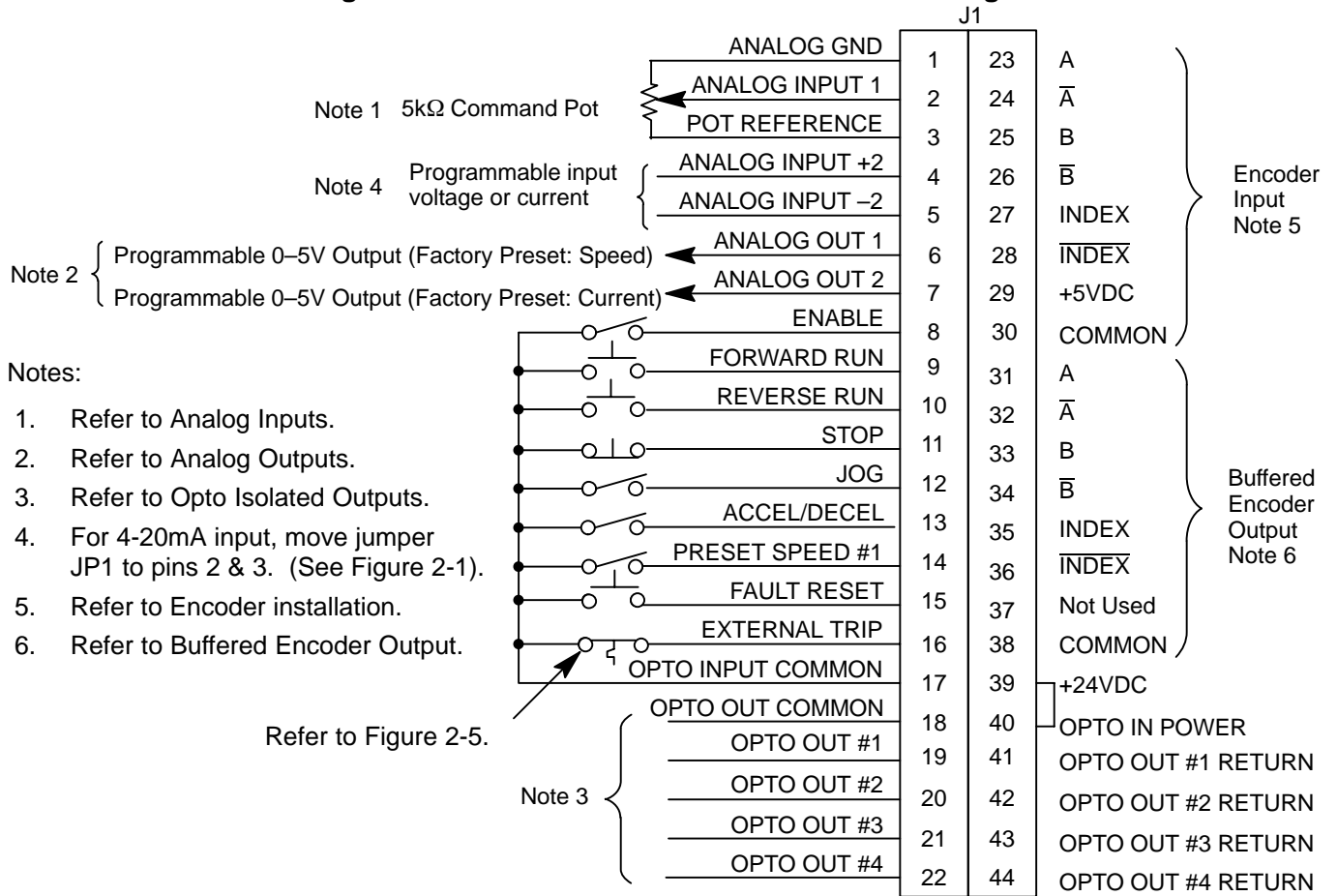

Terminal Tightening Torque = 7 Lb-in (0.8 Nm).

- J1-8 OPEN disables the control and motor coasts to a stop. CLOSED allows current to flow in the motor and produce torque.
- J1-9 MOMENTARY CLOSED starts motor operation in the Forward direction. In JOG mode (J1-12 CLOSED), continuous CLOSED jogs motor in the Forward direction.
- J1-10 MOMENTARY CLOSED starts motor operation in the Reverse direction. In JOG mode (J1-12 CLOSED), CONTINUOUS closed JOGS motor in the Reverse direction.
- J1-11 MOMENTARY OPEN causes motor to decel to stop (depending on Keypad Stop Mode parameter setting).
- J1-12 CLOSED places control in JOG mode, Forward and Reverse run are used to jog the motor.
- J1-13 OPEN selects ACC / DEC / S-CURVE group 1. CLOSED selects group 2.
- J1-14 CLOSED selects preset speed #1, (J1-12, will override this preset speed). OPEN allows speed command from Analog input #1 or #2 or Jog.
- J1-15 CLOSED to reset fault condition. OPEN to run.
- J1-16 OPEN causes an external trip to be received by control. The control will disable and display external trip when programmed "ON". When this occurs, the motor stop command is issued, drive operation is terminated and an external trip fault is displayed on the keypad display (also logged into the fault log). If J1-16 is connected, you must set Level 2 Protection block, External Trip to "ON".
- J1-39 & 40 Jumper as shown to power the Opto Outputs from the internal +24VDC supply.

15 Speed 2-Wire Mode Connections Switch Truth Table is defined in Table 2-6.

Operation in the 15 Speed 2-Wire mode is controlled by the Opto Isolated inputs at J1-8 through J1-16. The Opto inputs can be switches as shown in Figure 2-12 or logic signals from another device. The External Trip Opto Input at J1-16 is active if connected as shown and the Level 2 Protection block, External Trip parameter is set to ON.

Switched inputs at J1-11 through J1-14 allow selection of 15 preset speeds and provide Fault Reset as defined in Table 2-6.

Table 2-6 Switch Truth Table for 15 Speed, 2 Wire Control Mode

Function	J1-11	J1-12	J1-13	J1-14
Preset 1	Open	Open	Open	Open
Preset 2	Closed	Open	Open	Open
Preset 3	Open	Closed	Open	Open
Preset 4	Closed	Closed	Open	Open
Preset 5	Open	Open	Closed	Open
Preset 6	Closed	Open	Closed	Open
Preset 7	Open	Closed	Closed	Open
Preset 8	Closed	Closed	Closed	Open
Preset 9	Open	Open	Open	Closed
Preset 10	Closed	Open	Open	Closed
Preset 11	Open	Closed	Open	Closed
Preset 12	Closed	Closed	Open	Closed
Preset 13	Open	Open	Closed	Closed
Preset 14	Closed	Open	Closed	Closed
Preset 15	Open	Closed	Closed	Closed
Fault Reset	Closed	Closed	Closed	Closed

Figure 2-12 15 Speed 2-Wire Control Connection Diagram

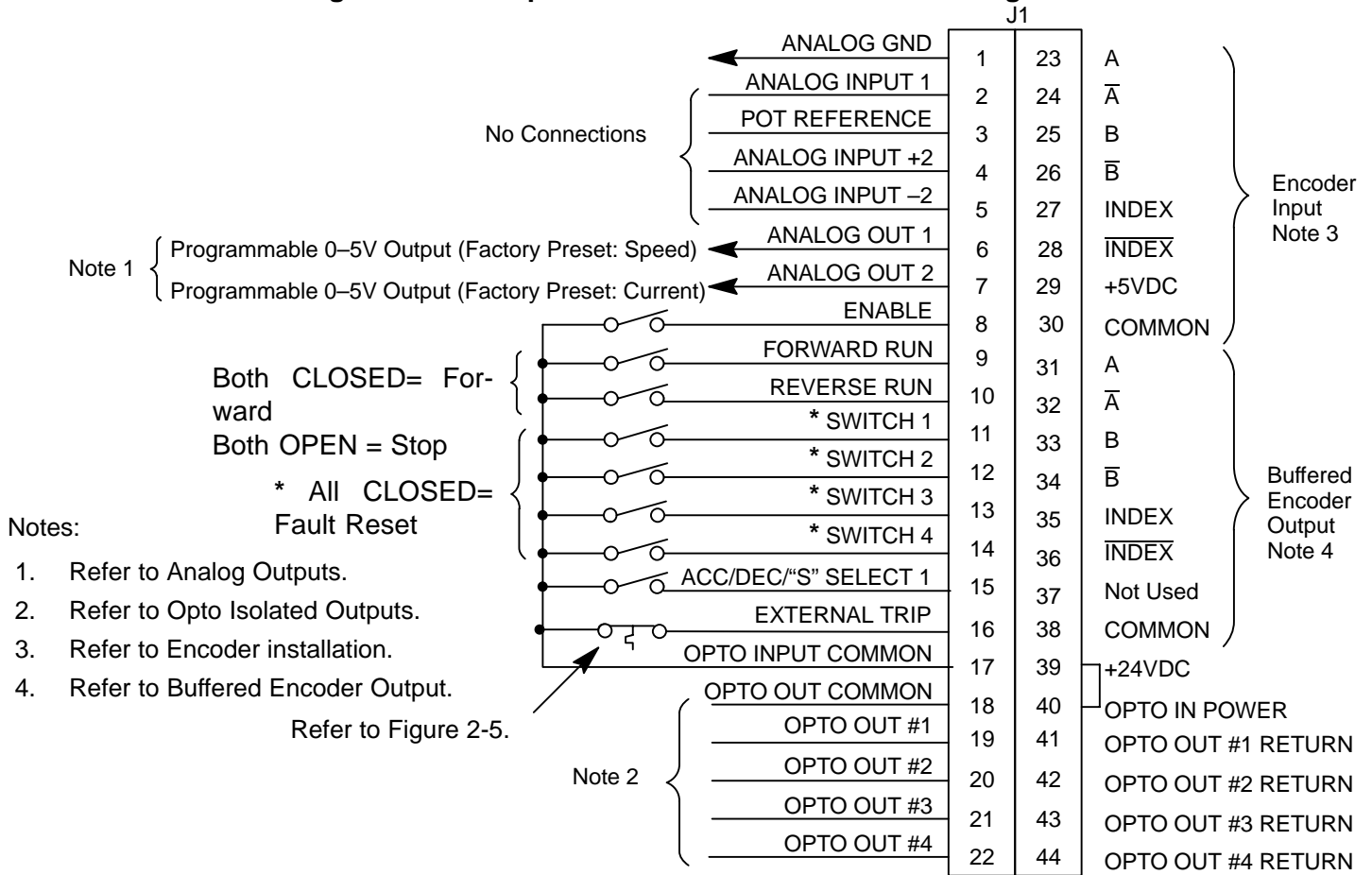

* Refer to truth table, Table 2-6.

Terminal Tightening Torque = 7 Lb-in (0.8 Nm).

- J1-8 OPEN disables the control & motor coasts to a stop. CLOSED allows current to flow in the motor and produce torque.
- J1-9 CLOSED operates the motor in the Forward direction (with J1-10 open). OPEN motor decels to stop (depending on Keypad Stop mode parameter setting).
- J1-10 CLOSED operates motor in the Reverse direction (with J1-9 open). OPEN motor decels to stop depending on Keypad Stop mode parameter setting.
- J1-11 to J1-14 Selects programmed preset speeds as defined in Table 2-6.
- J1-15 Selects ACC/DEC group. OPEN selects group 1. CLOSED selects group 2.
- J1-16 OPEN causes an external trip to be received by control. The control will disable and display external trip when programmed "ON". When this occurs, the motor stop command is issued, drive operation is terminated and an external trip fault is displayed on the keypad display (also logged into the fault log). If J1-16 is connected, you must set Level 2 Protection block, External Trip to "ON".
- J1-39 & 40 Jumper as shown to power the Opto Outputs from the internal +24VDC supply.

Bipolar Speed and Torque Mode Connections

In addition to individual motor bipolar speed or torque control, this mode of operation allows the user to store two (2) different complete sets of operating parameters. Table 2-7 shows switch settings required to access each parameter table. When programming each parameter set, use the ENTER key to accept and automatically save parameter values.

Note: Except for the Level 1 Operating Mode parameter, the control can be programmed in the REMOTE mode with the drive enabled and switches in step 4 closed. The control must be disabled to change the operating mode parameter.

1. Set the Level 1 INPUT block, Operating Mode parameter value to BIPOLAR in each of the parameter sets.
2. Open switch J1-13. Be sure switches J1-9 and J1-10 are OPEN, J1-8 is CLOSED. Enter all parameter values, and autotune as instructed in the Power-Up Procedure at the end of this section. This creates and saves the first parameter set which is numbered Table#0.
3. Close switch J1-13. Be sure switches J1-9 and J1-10 are OPEN, J1-8 is CLOSED. Enter all parameter values, and autotune as instructed in the Power-Up Procedure at the end of this section. This creates and saves the second parameter set which is numbered Table#1.
4. Remember that to change the value of a parameter in one of the parameter tables, you must first select the table using the switches. You cannot change a value in a table until you have first selected that table.

Table 2-7 Bipolar Mode Table Select Truth Table

Function	J1-13
Parameter Table #0	Open
Parameter Table #1	Closed

Note: All parameters except operating mode can be changed and saved for each table.

Note: Preset speed does not apply to table select.

Figure 2-13 Bipolar Speed or Torque Connection Diagram

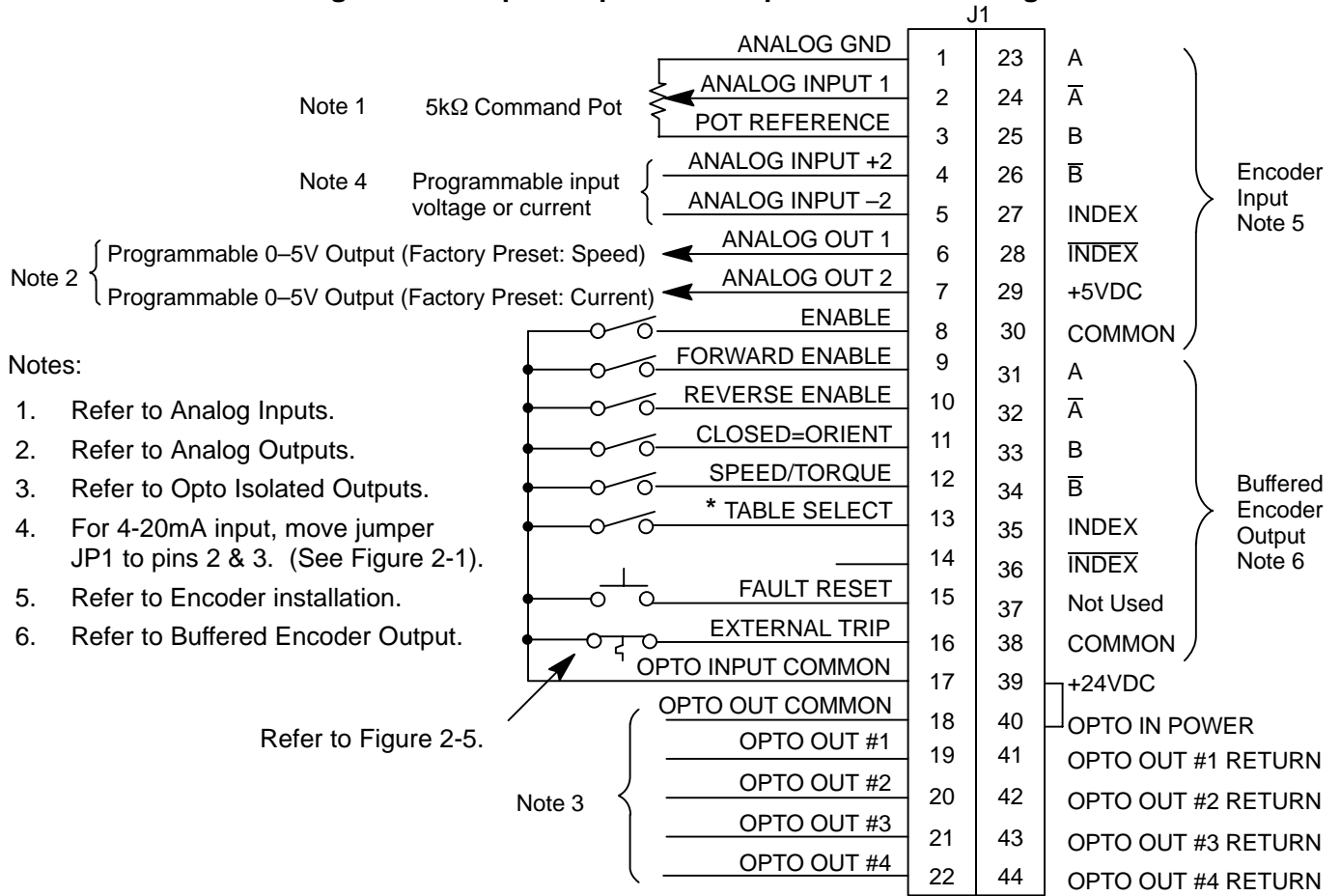

Terminal Tightening Torque = 7 Lb-in (0.8 Nm).

- J1-8 OPEN disables the control & motor coasts to a stop.
CLOSED allows current to flow in the motor and produce torque.
- J1-9 CLOSED to enable operation in the Forward direction.
OPEN TO DISABLE Forward operation (drive will brake to a stop if a Forward command is still present).
- J1-10 CLOSED to enable operation in the Reverse direction (if optional reversing contactor is used. Refer to Opto Isolated Outputs for more information.)
OPEN to disable Reverse operation (drive will brake to a stop if optional reversing contactor is used with the optional dynamic brake hardware. Refer to Opto Isolated Outputs for more information.).
- J1-11 Causes the motor shaft to orient to a marker or external switch.
- J1-12 CLOSED puts the control in torque mode.
OPEN puts the control in velocity mode.
- J1-13 OPEN selects Parameter Table 0.
CLOSED selects Parameter Table 1.
- J1-15 Momentary CLOSED to reset fault condition.
OPEN to run,
- J1-16 OPEN causes an external trip to be received by control. The control will disable and display external trip when programmed "ON". When this occurs, the motor stop command is issued, drive operation is terminated and an external trip fault is displayed on the keypad display (also logged into the fault log).
If J1-16 is connected, you must set Level 2 Protection block, External Trip to "ON".
- J1-39 & 40 Jumper as shown to power the Opto Outputs from the internal +24VDC supply.

Process Mode Connections

The process control mode is a secondary closed loop system which includes a general purpose set point PID control. It may be setup in two different ways. One uses a programmable preset set point and the other uses an external command set point input. In either case, a process feedback signal will be required.

The selection of the set point command and the process feedback signal is located in the Process Control programming block under the Set point Source Parameter and Process Feedback Parameter respectively.

The programmable preset set point PID control mode can be used for most general closed loop systems. This is generally known as feedback control. This method compares the value of the programmed preset variable with the process variable. The difference between them is the process error. The process error is then converted to a signal that adjusts the speed or torque of the motor to eliminate the error. A large process error will result in a large change in the rate of speed or amount of torque generated by the motor. Likewise, a small error signal will produce a small change in the rate of speed or amount of torque generated by the motor. The end result is the PID control will adjust the motor speed or torque to force the process variable to be as close as possible to the programmed preset setpoint.

The external command setpoint input PID control mode is used for more complex applications having a large external disturbance that can affect the process variable. This is useful for processes that have significant time lag between a process disturbance and the generation of a process error signal from the process sensor. This mode uses a feed forward command to anticipate changes in the process. This feed forward signal directly changes the motor speed or torque without having to develop a process error signal first.

Figure 2-14 shows a block diagram of the Process Mode control system. The user must make the determination of which technique to implement.

Figure 2-14 Simplified Process Control Block Diagram

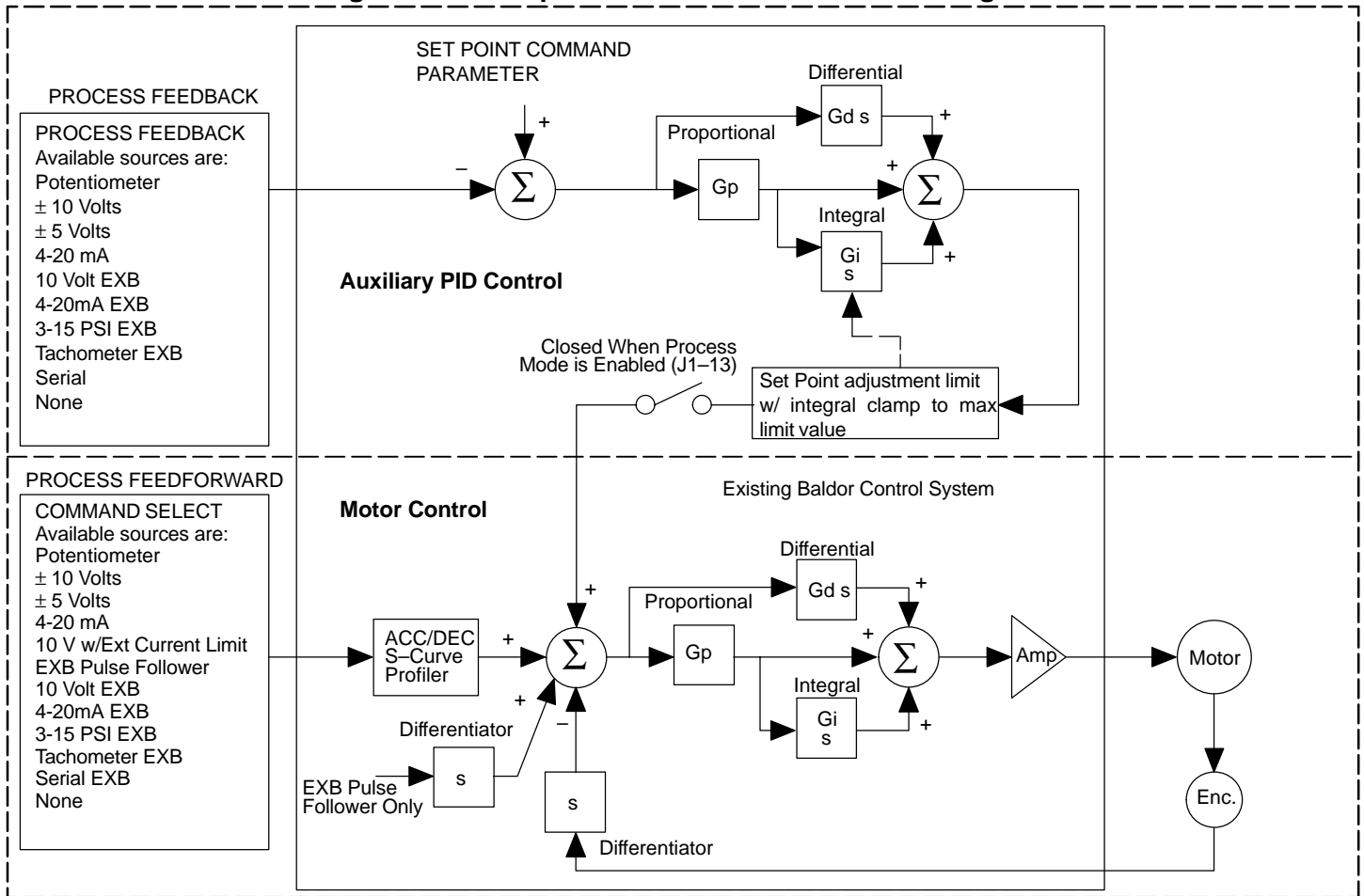

Table 2-8 Process Mode Input Signal Compatibility

	J1-1 & 2	J1-4 & 5	5V EXB ^①	10V EXB ^①	4-20mA EXB ^①	3-15 PSI EXB ^②	DC Tach EXB ^③	MPR/F EXB ^④
J1-1 & 2	■							
J1-4 & 5		■						
5V EXB ^①			■	■	■	▨		
10V EXB ^①			■	■	■	▨		
4-20mA EXB ^①			■	■	■	▨		
3-15 PSI EXB ^②			▨	▨	▨	■		
DC Tach EXB ^③							■	
MPR/F EXB ^④								■

- ① Requires expansion board EXB007A01 (High Resolution Analog I/O EXB).
- ② Requires expansion board EXB04A01 (4 Output Relays/3-15 PSI Pneumatic Interface EXB).
- ③ Requires expansion board EXB06A01 (DC Tachometer Interface EXB).
- ④ Requires expansion board EXB05A01 (Master Pulse Reference/Isolated Pulse Follower EXB).

■ Conflicting inputs. Do not use same input signal multiple times.

▨ Conflicting level 1 or 2 expansion boards. Do not use!

Specific Process Mode Outputs

Process Mode Only, Analog Monitoring Outputs

<u>Name</u>	<u>Description</u>
Process FDBK	Process Feedback scaled input. Useful for observing or tuning the process control loop.
Setpoint CMD	Setpoint Command scaled input. Useful for observing or tuning the process control loop.
Speed Command	Commanded Motor Speed. Useful for observing or tuning the output of the control loop.

Process Mode Only, Opto Isolated Outputs

<u>Name</u>	<u>Description</u>
Process Error	CLOSED when the Process Feedback is within the specified tolerance band. OPEN when the Process Feedback is greater than the specified tolerance band. The width of the tolerance band is adjusted by the Level 2 Process Control block Process ERR TOL parameter value.

Figure 2-15 Process Mode Connection Diagram

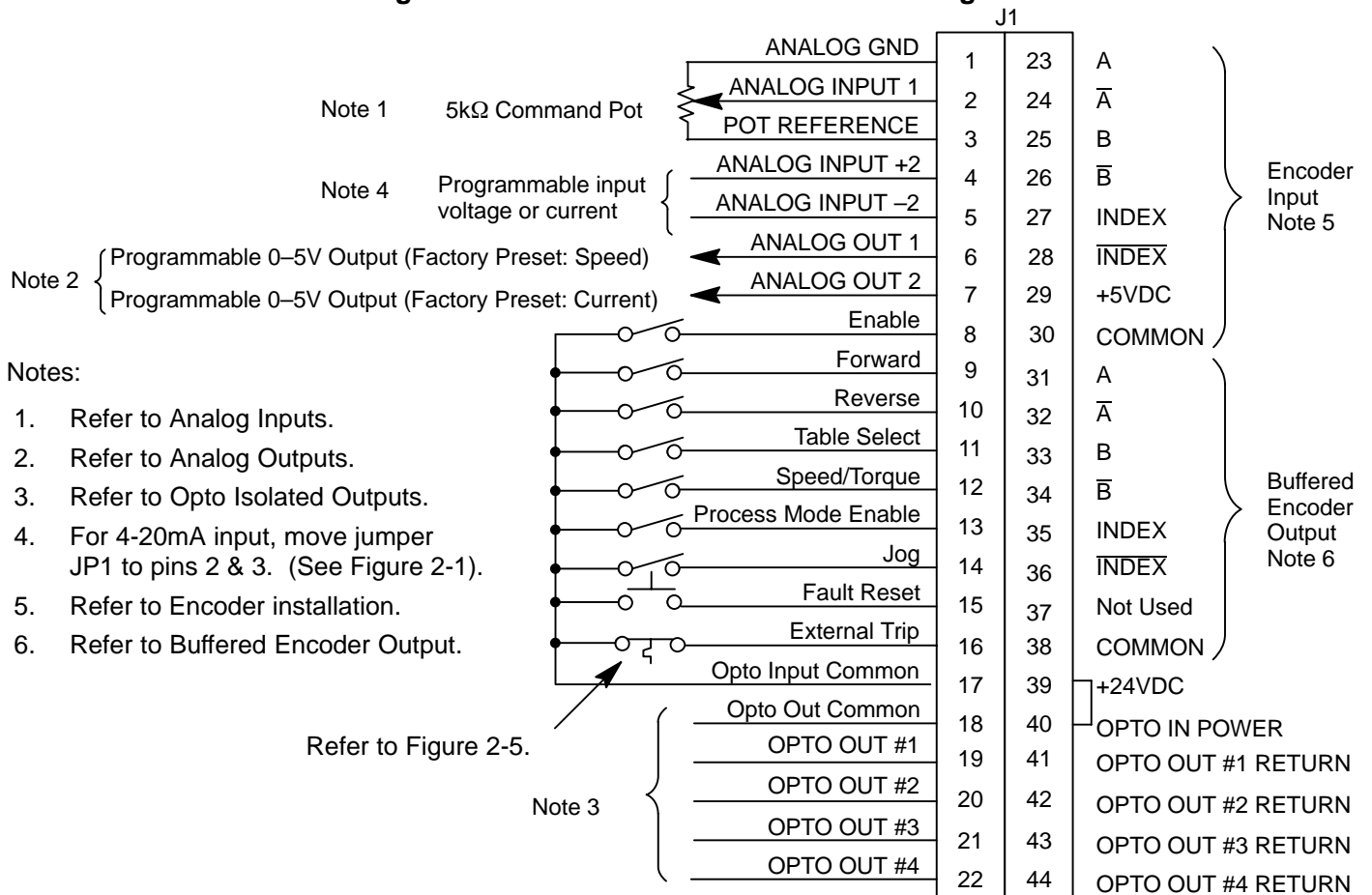

Terminal Tightening Torque = 7 Lb-in (0.8 Nm).

- J1-8 OPEN disables the control & motor coasts to a stop. Closed allows current to flow in the motor and produce torque.
- J1-9 CLOSED operates the motor in the Forward direction (with J1-10 open). OPEN motor decels to stop (depending on Keypad Stop mode parameter setting).
- J1-10 CLOSED operates motor in the Reverse direction (with J1-9 open). OPEN motor decels to stop depending on Keypad Stop mode parameter setting.
- J1-11 OPEN = TABLE 0, CLOSED = TABLE 1
- J1-12 CLOSED, the control is in torque mode. OPEN, the control is in velocity mode.
- J1-13 CLOSED to enable the Process Mode.
- J1-14 CLOSED places control in JOG mode. The control will only JOG in the forward direction.
- J1-15 Momentary CLOSED to reset a fault condition. OPEN to run.
- J1-16 OPEN causes an external trip to be received by control. The control will disable and display external trip when programmed "ON". When this occurs, the motor stop command is issued, drive operation is terminated and an external trip fault is displayed on the keypad display (also logged in the fault log). If J1-16 is connected, you must set Level 2 Protection block, External Trip to "ON".
- J1-39 & 40 Jumper as shown to power the Opto Outputs from the internal +24VDC supply.

Analog Inputs and Outputs

Analog Inputs

Two analog inputs are available: analog input #1 (J1-1 and J1-2) and analog input #2 (J1-4 and J1-5) as shown in Figure 2-16. Either analog input may be selected in the Level 1 INPUT block, Command Select parameter value. Analog input #1 is selected if parameter value "Potentiometer" is selected. Analog input #2 is selected if parameter value "+/-10Volts, +/-5 Volts or 4-20mA" is selected.

Figure 2-16 Analog Inputs and Outputs

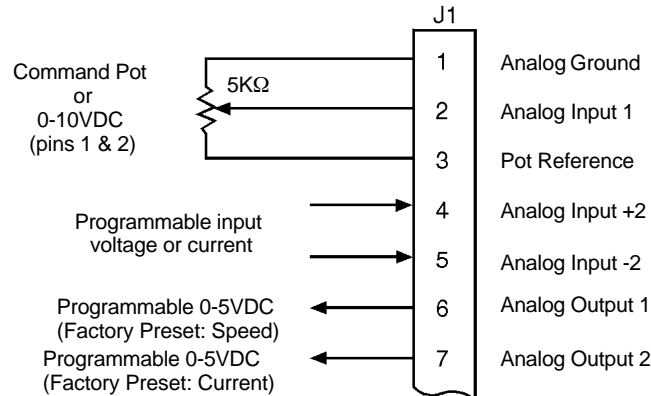

Terminal Tightening Torque = 7 Lb-in (0.8 Nm).

Analog Input #1

The single ended analog input #1 is used when the controller is set to Standard 3 Wire Control, Process, or Bipolar Control. When using a potentiometer as the speed command, process feedback or setpoint source, the Level 1 Input block COMMAND SELECT parameter must be set to "POTENTIOMETER".

1. Connect the wires from the 5KΩ pot as shown in Figure 2-16. One end of the pot is connected to J1-1 (analog ground) and the other end is connected to J1-3 (reference voltage).
2. Connect the wiper of the pot to J1-2. The voltage across terminals J1-1 and J1-2 is the speed command input.
3. A 0-10VDC speed command signal may be connected across J1-1 and J1-2 instead of a 5KΩ pot.

Analog Input #2

Analog input #2 accepts a differential command $\pm 5\text{VDC}$, $\pm 10\text{VDC}$ or 4-20 mA. The operating mode is defined in the of the Level 1 Input block COMMAND SELECT parameter.

Note: Analog Input #2 is used with Standard Run 3-Wire or Bipolar Control modes and not used for the 15 Speed 2 Wire or the Serial operating modes.

1. Connect the Analog Input +2 wire to J1-4 and the -2 wire to J1-5.
2. If using a 4-20 mA command signal, jumper JP1 located on the main control board must be on pins 2 and 3. For all other modes, JP1 must be on pins 1 and 2. Refer to Figure 2-1 for jumper position information.

Note: Analog Input #2 can be connected for single ended operation by grounding either of the inputs, provided the common mode voltage range is not exceeded. The common mode voltage can be measured with a voltmeter. Apply the maximum command voltage to analog input 2 (J1-4, 5). Measure the AC and DC voltage across J1-1 to J1-4. Add the AC and DC readings together. Measure the AC and DC voltage from J1-1 to J1-5. Add the AC and DC readings together.

If either of these measurement totals exceeds a total of ± 15 volts, then the common mode voltage range has been exceeded. If the common mode voltage range has been exceeded, the solution is either to change the command voltage source or isolate the command voltage with a commercially available signal isolator.

Analog Outputs

Two programmable analog outputs are provided on J1-6 and J1-7. See Figure 2-17. These outputs are scaled 0 - 5 VDC (1mA maximum output current) and can be used to provide real-time status of various control conditions. The output conditions are defined in Table 3-2 of Section 3 of this manual.

The return for these outputs is J1-1 analog ground. Each output is programmed in the Level 1 Output block.

1. Connect the Output #1 wires to J1-6 and J1-1.
2. Connect the Output #2 wires to J1-7 and J1-1.

Figure 2-17 Analog Outputs Equivalent Circuits

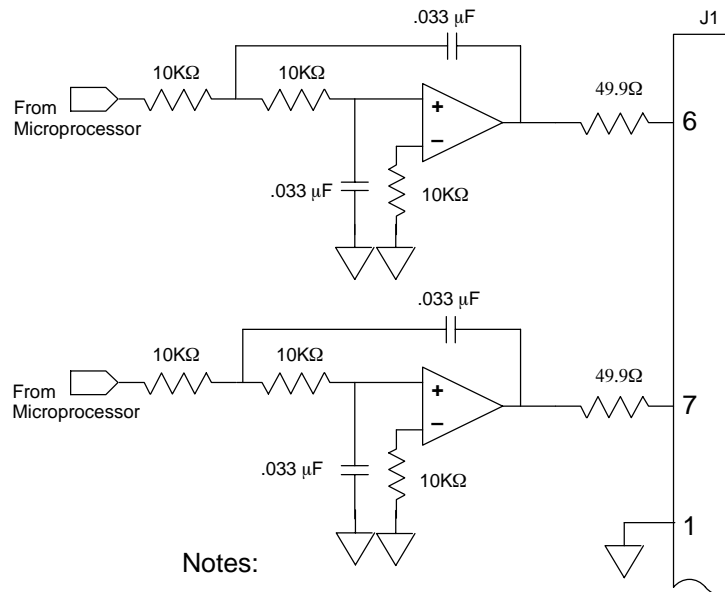

Notes:

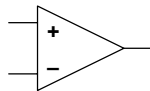

All OP Amps are TL082 or TL084



Analog Ground is separated from Chassis Ground. Electrically they are separated by an RC network.

Terminal Tightening Torque = 7 Lb-in (0.8 Nm).

Opto-Isolated Inputs

The equivalent circuit for the nine Opto inputs is shown in Figure 2-18. The function of each input depends on the operating mode selected. Refer to the operating mode connection diagrams shown previously in this section.

Figure 2-18 Opto-Input Equivalent Circuit

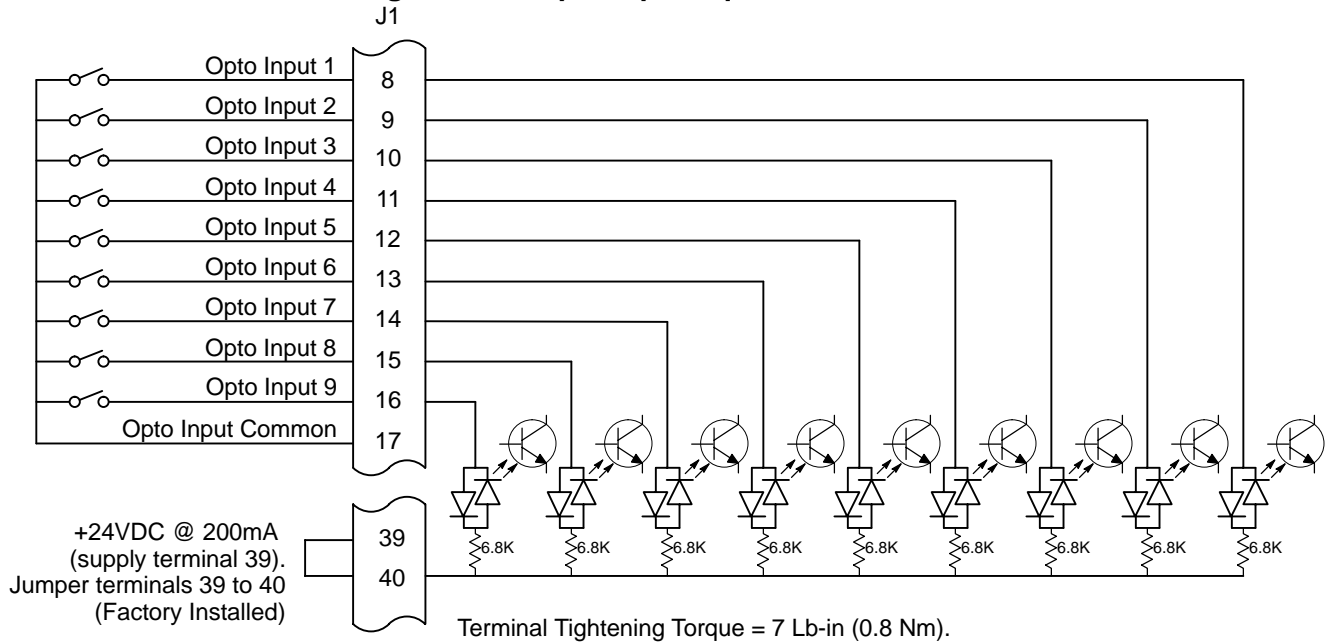

Opto-Isolated Outputs

Four programmable Opto-isolated outputs are available at terminals J1-19 through J1-22. See Figure 2-19. Each output may be programmed to represent one output condition. The output conditions are defined in Table 3-2 of Section 3 of this manual.

The Opto-isolated outputs may be configured for sinking or sourcing 60 mA each. However, all must be configured the same. The maximum voltage from opto output to common when active is 1.0 VDC (TTL compatible). The Opto-isolated outputs may be connected in different ways as shown in Figure 2-19. The equivalent circuit for the Opto-isolated outputs is shown in Figure 2-20.

If the opto outputs are used to directly drive a relay, a flyback diode rated at 1A, 100 V (IN4002) minimum should be connected across the relay coil. See Electrical Noise Considerations in Section 4 of this manual.

1. Connect OPTO OUT #1 wires to J1-19 and J1-41.
2. Connect OPTO OUT #2 wires to J1-20 and J1-42.
3. Connect OPTO OUT #3 wires to J1-21 and J1-43.
4. Connect OPTO OUT #4 wires to J1-22 and J1-44.

Each Opto Output is programmed in the Output programming block.

Figure 2-19 Opto-isolated Output Configurations

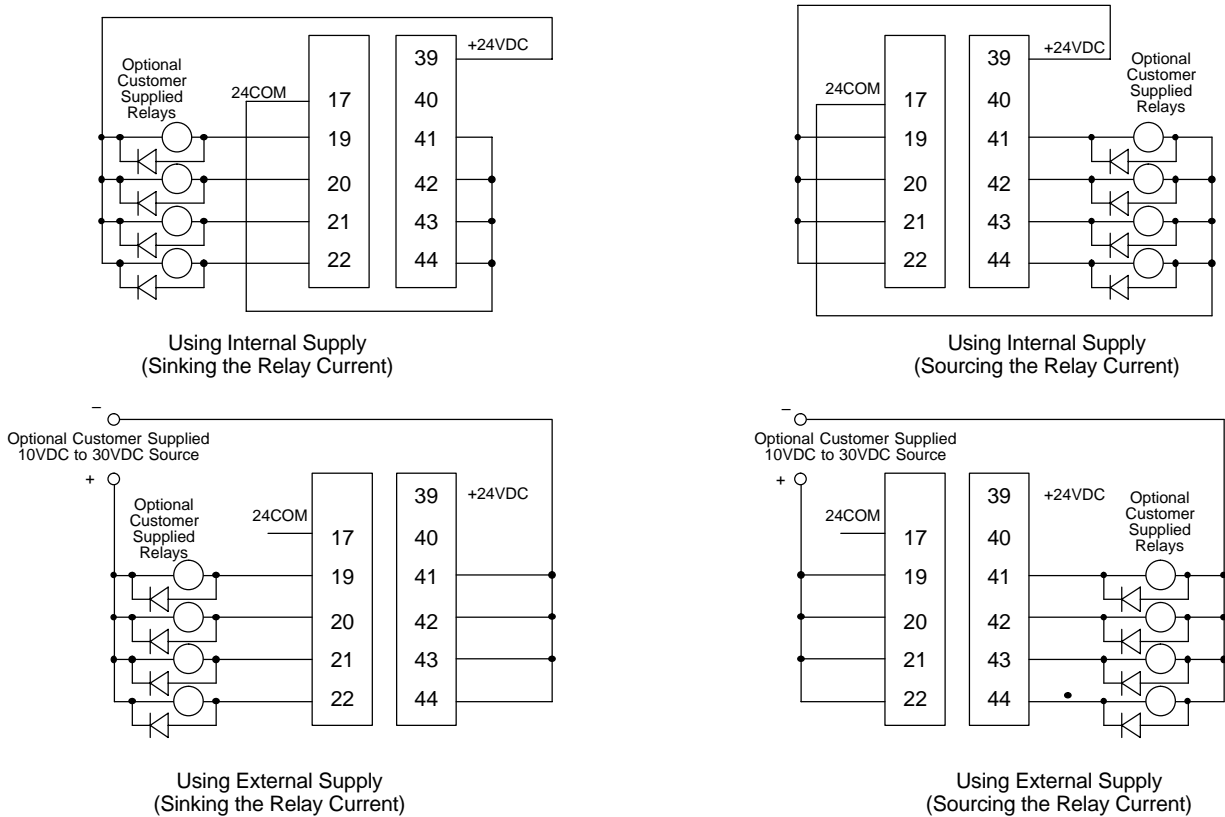

Terminal Tightening Torque = 7 Lb-in (0.8 Nm).

Figure 2-20 Opto-Output Equivalent Circuit

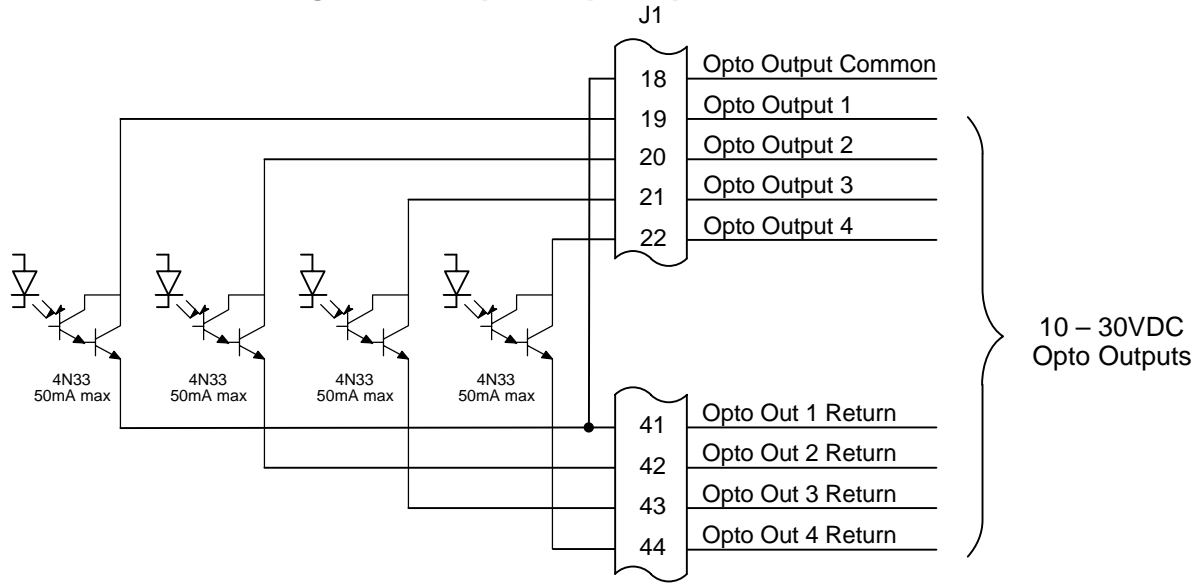

Terminal Tightening Torque = 7 Lb-in (0.8 Nm).

Reversing Contactor

The reversing contactor may optionally be used with either encoder or tachometer feedback devices. However, when the motor counter EMF (or back EMF) is used for feedback, the armature voltage sense lines must be connected to the motor side of the reversing contactor.

The electrical connections are shown in Figure 2-21. To install the reversing contactor, the yellow and brown motor leads must be removed from the backside of A1 and A2 control terminals and attached to the motor side of the reversing contactor. Figure 2-1 shows the location of the A1 and A2 terminals.

Be sure all power to the control is disconnected before proceeding.

1. For some controls, it may be necessary to move the Control Circuit board to access the A1 and A2 terminals. The top two (2) screws above the control board may be removed and the control board will swing down to allow access of A1 and A2 terminals.
2. Disconnect the yellow wire from the backside of the A1 terminal.
3. Connect the yellow wire to the motor side of the reversing contactor.
4. Disconnect the brown wire from the backside of the A2 terminal.
5. Connect the brown wire to the motor side of the reversing contactor.
6. If the control board was moved in step1, swing the board back to its position and secure using the screws removed in step1.

Note: The reversing contact may only be connected to Straight Shunt motors. Motors that are stabilized shunt or compound will not operate properly with their series fields connected.

Figure 2-21 Reversing Contactor Connection

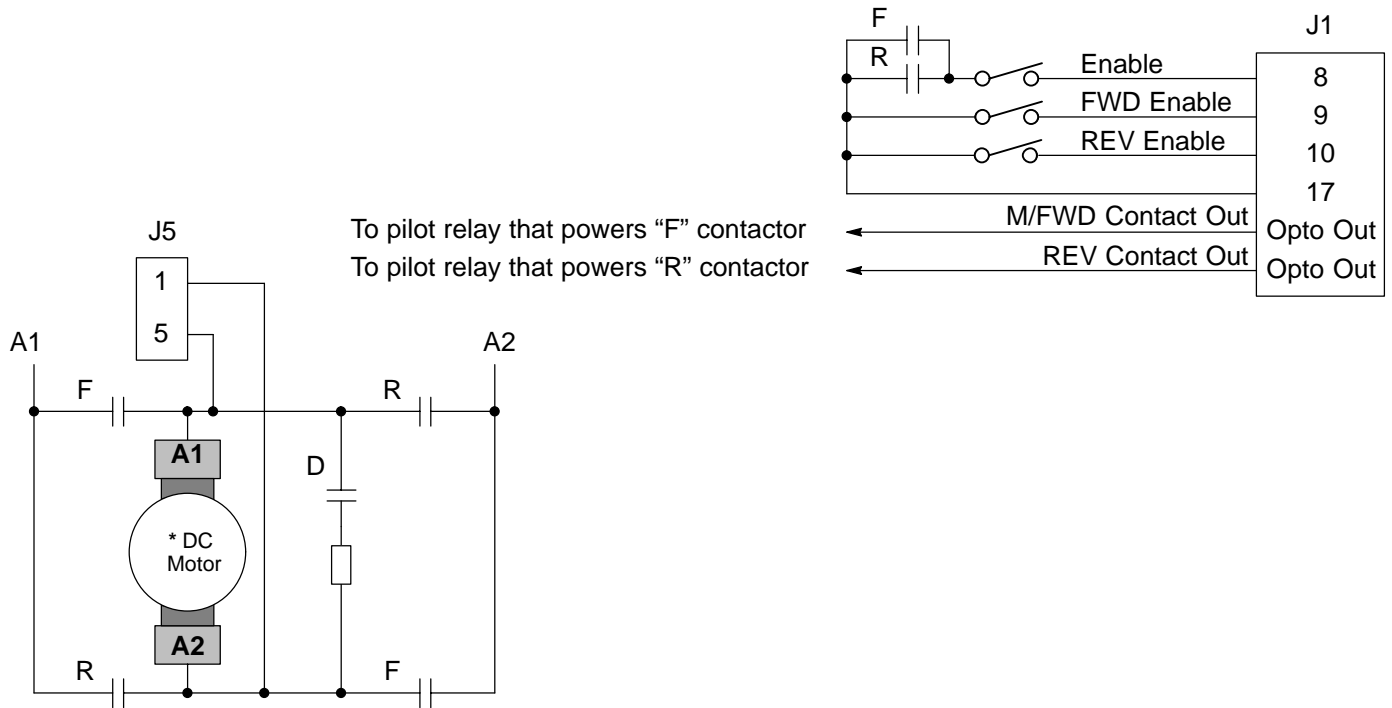

Pre-Operation Checklist

Check of Electrical Items

⚠ CAUTION: After completing the installation but before you apply power, be sure to check the following items.

1. Verify AC line voltage at source matches control rating.
2. Inspect all power connections for accuracy, workmanship and tightness and compliance to codes.
3. Verify control and motor are grounded to each other and the control is connected to earth ground.
4. Check all signal wiring for accuracy.
5. Be certain all brake coils, contactors and relay coils have noise suppression. This should be an R-C filter for AC coils and reverse polarity diodes for DC coils. MOV type transient suppression is not adequate.

⚠ WARNING: Make sure that unexpected operation of the motor shaft during start up will not cause injury to personnel or damage to equipment.

Check of Motors and Couplings

1. Verify freedom of motion for all motor shafts and that all motor couplings are tight without backlash.
2. Verify the holding brakes if any, are properly adjusted to fully release and set to the desired torque value.

Power-Up Procedure

This procedure will help get your system up and running in the keypad mode quickly and allow you to prove the motor and control operation. This procedure assumes that the control and motor are correctly installed and that you have an understanding of the keypad programming & operation procedures. It is not necessary to wire the terminal strip to operate the motor in the Keypad mode.

Initial Conditions

Be sure the control and motor are wired according to the procedures described previously in this section. Become familiar with the keypad programming and keypad operation of the control as described in Section 3 of this manual.

1. Verify that any enable inputs to J1-8 are open.
2. Turn power on. Be sure there are no faults.
3. Set the Level 1 Input block, Operating Mode to "KEYPAD".
4. Enter the following motor data in the Level 2 Motor Data block parameters:
Armature Voltage
ARM Rated Amps
Motor Rated Speed
Motor Field (Shunt or Permanent Magnet)
Motor Field Volts
Motor Field Amps
5. Set the feedback type to Armature, Encoder, Resolver or Tachometer in the Level 2 Motor Data block, Feedback Type parameter.
6. If feedback type is Armature, skip this step.
If Encoder, Tachometer or Resolver feedback type was selected, set one of the following corresponding Level 2 Motor Data block parameters:
Encoder Counts (ppr)
Resolver Speed
Tachometer Volts (VDC per 1000 RPM)
7. Go to Level 2 Autotune block, press ENTER, at CALC PRESETS select YES (using the ▲ key) and let the control calculate preset values for the parameters that are necessary for control operation.
8. Set the Level 2 Output Limits block, "MIN OUTPUT SPEED" parameter.
9. Set the Level 2 Output Limits block, "MAX OUTPUT SPEED" parameter.
10. Disconnect all input power.
11. Disconnect the motor from the load (including coupling or inertia wheels). If the load cannot be disconnected, do not perform the Feedback tests in step 13.
12. Connect input power.
13. Go to Level 2 Autotune block, and do the following tests:
CMD OFFSET TRIM
CUR LOOP COMP
FEEDBACK TESTS (Only if load is disconnected)
SPD CNTRLR CALC
14. Disconnect all input power.
15. Couple the motor to its load.
16. Connect input power.
17. Go to Level 2 Autotune block, and again do the SPD CNTRLR CALC test.
18. Select additional parameters to customize the control to the application (MAX SPEED, etc.).

Section 3

Programming and Operation

Overview

The keypad is used to program the control parameters, operate the motor and monitor the status and outputs of the control by accessing the display options, diagnostic menus and the fault log.

Figure 3-1 Keypad

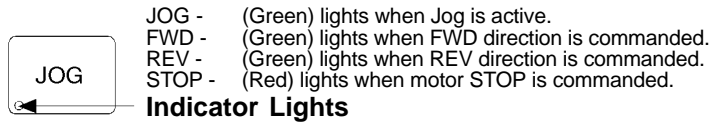

JOG - Press JOG to select the preprogrammed jog speed. After the jog key has been pressed, use the FWD or REV keys to run the motor in the direction that is needed. The JOG key is only active in the local mode.

FWD - Press FWD to initiate forward rotation of the motor. This key is only active in the Keypad or local mode.

REV - Press REV to initiate reverse rotation of the motor. This key is active only in the Keypad or local mode.

STOP - Press STOP one time to initiate a stop sequence. Depending on the setup of the control, the motor will either ramp or coast to a stop. This key is operational in all modes of operation unless it has been disabled by the Keypad Stop parameter in the Keypad (programming) Setup Block. Press STOP twice to disable control (coast to stop).

Note: If the control is operating in remote mode and the stop key is pressed the control will change to the local mode when the stop command is initiated. To resume operation in the remote mode, press the LOCAL key.

LOCAL - Press LOCAL to change between the local (keypad) and remote operation. When the control is in the local mode all other external commands to the J1 terminal strip will be ignored with the exception of the external trip input.

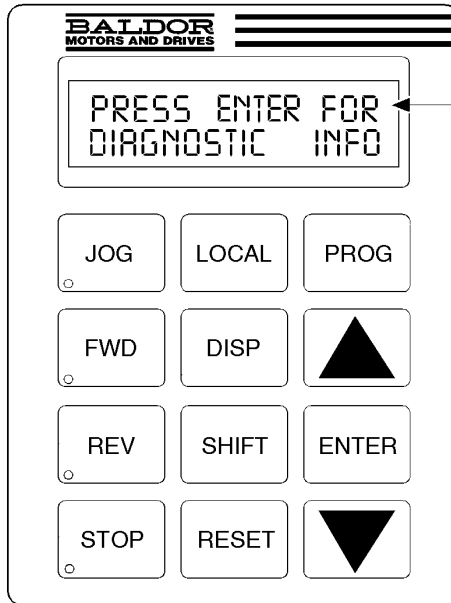

Keypad Display - Displays status information during Local or Remote operation. It also displays information during parameter setup and fault or Diagnostic Information.

PROG - Press PROG to enter the program mode. While in the program mode the PROG key is used to edit a parameter setting.

▲ - (UP Arrow).
Press ▲ to change the value of the parameter being displayed. Pressing ▲ increments the value to the next greater value. Also, when the fault log or parameter list is displayed, the ▲ key will scroll upward through the list. In the local mode pressing the ▲ key will increase motor speed to the next greater value.

ENTER - Press ENTER to save parameter value changes and move back to the previous level in the programming menu. In the display mode the ENTER key is used to directly set the local speed reference. It is also used to select other operations when prompted by the keypad display.

▼ - (Down Arrow)
Press ▼ to change the value of the parameter being displayed. Pressing ▼ decrements the value to the next lesser value. Also, when the fault log or parameter list is displayed, the ▼ key will scroll downward through the list. In the local mode pressing the ▼ key will decrease motor speed to the next lower value.

DISP - Press DISP to return to display mode from programming mode. Provides operational status and advances to the next display menu item including the diagnostic screens.

SHIFT - Press SHIFT in the program mode to control cursor movement. Pressing the SHIFT key once moves the blinking cursor one character position to the right. While in program mode, a parameter value may be reset to the factory preset value by pressing the SHIFT key until the arrow symbols at the far left of the keypad display are flashing, then press an arrow key. In the display mode the SHIFT key is used to adjust the keypad contrast.

RESET - Press RESET to clear all fault messages (in local mode). Can also be used to return to the top of the block programming menu without saving any parameter value changes.

Display Mode

The control is in the DISPLAY MODE at all times except when parameter values are changed (Programming mode). The Keypad Display shows the status of the control as in the following example.



The DISPLAY MODE is used to view DIAGNOSTIC INFO and the FAULT LOG. The description of how to do these tasks are described on the following pages.

Adjusting Display Contrast When AC power is applied to the control the keypad should display the status of the control. If there is no visible display, use the following procedure to adjust the contrast of the display.

(Contrast may be adjusted in display mode when motor is stopped or running)

Action	Description	Display	Comments
Apply Power	No visible display	BLANK	
Press DISP Key	Places control in display mode	BLANK	
Press SHIFT SHIFT	Allows display contrast adjustment	ADJUST CONTRAST ⬇ (ENTER) TO SAVE	
Press ▲ or ▼ Key	Adjusts display intensity	ADJUST CONTRAST ⬇ (ENTER) TO SAVE	
Press ENTER	Saves level of contrast and exits to display mode	STOP MOTOR SPEED LOCAL 0 RPM	Typical display

Display Mode Continued
Display Mode Screens

Action	Description	Display	Comments
Apply Power		<pre>BALDOR MOTORS & DRIVES</pre>	Logo display for 5 seconds.
	Display mode showing motor speed.	<pre>STOP MOTOR SPEED LOCAL 0 RPM</pre>	No faults present. Local keypad mode. If in remote/serial mode, press local for this display.
Press DISP key	Display mode custom unit output rate (only if Level 2 Custom Units block parameters are set).	<pre>STOP OUTPUT RATE LOCAL 00000 XXXX</pre>	
Press DISP key	Display Frequency	<pre>STOP FREQUENCY LOCAL 0.00 HZ</pre>	First Display Mode Screen.
Press DISP key	Display Current	<pre>STOP CURRENT OUT LOCAL 0.00 A</pre>	
Press DISP key	Display Voltage	<pre>STOP VOLTAGE OUT LOCAL 0 V</pre>	
Press DISP key	Combined Display	<pre>STP 0V 0 RPM LOC 0.0A 0.0 HZ</pre>	
Press DISP key	Screen to enter Fault Log	<pre>PRESS ENTER FOR FAULT LOG</pre>	
Press DISP key	Screen to enter Diagnostic Menu	<pre>PRESS ENTER FOR DIAGNOSTIC INFO</pre>	
Press DISP key	Exit Display mode and return to Motor Speed display	<pre>STOP MOTOR SPEED LOCAL 0 RPM</pre>	

Display Mode Continued





Display Screens & Diagnostic Information Access

Action	Description	Display	Comments
Apply Power		<pre>BALDOR MOTORS & DRIVES</pre>	Logo display for 5 seconds.
	Display mode showing motor speed.	<pre>STOP MOTOR SPEED LOCAL 0 RPM</pre>	No faults present. Local keypad mode. If in remote/serial mode, press local for this display.
Press DISP key 6 times	Scroll to Diagnostic Information screen	<pre>PRESS ENTER FOR DIAGNOSTIC INFO</pre>	Diagnostic Access screen.
Press ENTER key	Access diagnostic information.	<pre>STOP SPEED REF LOCAL 0 RPM</pre>	First Diagnostic Information screen.
Press DISP key	Display mode showing control temperature.	<pre>STOP CONTROL TEMP LOCAL 0.0° C</pre>	
Press DISP key	Display mode showing % overload current remaining.	<pre>STOP OVRLD LEFT LOCAL 100.00%</pre>	
Press DISP key	Display mode showing opto inputs & outputs states. 0=Open, 1=Closed	<pre>DIGITAL I/O 00000000 0000</pre>	Opto Inputs states (Left); Opto Outputs states (Right).
Press DISP key	Display mode showing actual drive running time.	<pre>TIME FROM PUR UP 0000000.01.43</pre>	HR.MIN.SEC format.
Press DISP key	Display mode showing operating zone, voltage and control type.	<pre>100HP ONWAY 460V DIGITAL DC</pre>	
Press DISP key	Display mode showing continuous amps; PK amps rating; amps/volt scale of feedback, power base ID.	<pre>X.XA X.X APK X.XX A/V ID:XXX</pre>	ID is displayed as a hexadecimal value.
Press DISP key	Display mode showing which Group1 or 2 expansion boards are installed.	<pre>G1 NOT INSTALLED G2 NOT INSTALLED</pre>	
Press DISP key	Display mode showing motor shaft revolutions from the REV home set point.	<pre>POSITION COUNTER + 000.0000 REV</pre>	
Press DISP key	Display mode showing firmware version and revision installed in the control.	<pre>SOFTWARE VERSION SXX-X.XX</pre>	
Press DISP key	Displays exit choice.	<pre>PRESS ENTER FOR DIAGNOSTIC EXIT</pre>	Press ENTER to exit diagnostic information.

Display Mode Continued

Fault Log Access

When a fault condition occurs, motor operation stops and a fault code is displayed on the Keypad display. The control keeps a log of up to the last 31 faults. If more than 31 faults have occurred the oldest fault will be deleted from the fault log to make room for the newest fault. To access the fault log perform the following procedure:

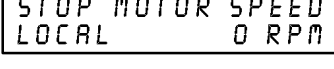
Action	Description	Display	Comments
Apply Power			Logo display for 5 seconds.
	Display mode showing motor speed.		Display mode.
Press DISP key 5 times	Scroll to the Fault Log screen		Fault Log access screen.
Press ENTER key	Display first fault type and time fault occurred.		Most recent fault displayed.
Press ▲ key	Scroll through fault messages.		If no messages, the fault log exit choice is displayed.
Press ENTER key	Return to display mode.		Display mode stop key LED is on.

Program Mode

The Program Mode is used to:

1. Enter motor data.
2. Autotune the motor.
3. Customize the drive (Control and Motor) parameters to your application.

From the Display Mode press the PROG key to access the Program Mode.

Note: When a parameter is selected, alternately pressing the Disp and Prog keys will toggle between the Display Mode and the selected parameter. When a parameter is selected for programming, the keypad display gives you the following information:

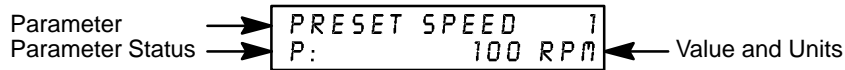

Parameter Status. All programmable parameters are displayed with a “P:” in the lower left corner of the keypad display. If a parameter is displayed with a “V:”, the parameter value may be viewed but not changed while the motor is operating. If the parameter is displayed with an “L:”, the value is locked and the security access code must be entered before its’ value can be changed.

Parameter Blocks Access for Programming

Use the following procedure to access parameter blocks to program the control.





Action	Description	Display	Comments
Apply Power	Keypad Display shows this opening message.	<pre>BALDOR MOTORS & DRIVES</pre>	Logo display for 5 seconds.
	If no faults and programmed for LOCAL operation.	<pre>STOP MOTOR SPEED LOCAL 0 RPM</pre>	Display mode.
	If no faults and programmed for REMOTE operation.	<pre>OFF MOTOR SPEED REMOTE 0 RPM</pre>	If fault is displayed, refer to the Troubleshooting section of this manual.
Press PROG key		<pre>PRESS ENTER FOR PRESET SPEEDS</pre>	Press ENTER to access Preset Speed parameters.
Press ▲ or ▼ key	Scroll to the ACCEL/DECEL block.	<pre>PRESS ENTER FOR ACCEL/DECEL RATE</pre>	Press ENTER to access Accel and Decel rate parameters.
Press ▲ or ▼ key	Scroll to the Level 2 Block.	<pre>PRESS ENTER FOR LEVEL 2 BLOCKS</pre>	Press ENTER to access Level 2 Blocks.
Press ENTER key	First Level 2 block display.	<pre>PRESS ENTER FOR OUTPUT LIMITS</pre>	
Press ▲ or ▼ key	Scroll to Programming Exit menu.	<pre>PRESS ENTER FOR PROGRAMMING EXIT</pre>	Press ENTER to return to Display mode.
Press ENTER key	Return to display mode.	<pre>STOP MOTOR SPEED LOCAL 0 RPM</pre>	

Program Mode Continued

Changing Parameter Values when Security Code Not Used

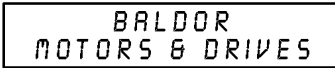
Use the following procedure to program or change a parameter already programmed into the control when a security code is not being used.

The example shown changes the operating mode from Keypad to Bipolar.

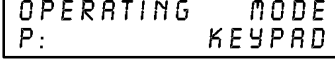
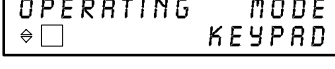
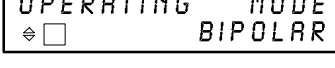
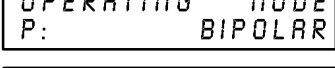
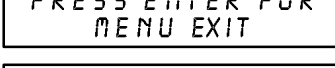
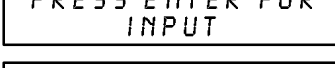
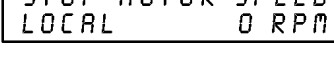
Action	Description	Display	Comments
Apply Power	Keypad Display shows this opening message.		Logo display for 5 seconds.
	If no faults and programmed for LOCAL operation.		Display mode. Stop LED on.
Press PROG key	Access programming mode.		
Press ▲ or ▼ key	Scroll to Level 1 Input Block.		Press ENTER to access INPUT block parameter.
Press ENTER key	Access Input Block.		Keypad mode shown is the factory setting.
Press ENTER key	Access Operating Mode parameter.		Keypad mode shown is the factory setting.
Press ▲ key	Scroll to change selection.		At flashing cursor, select desired mode, BIPOLAR in this case.
Press ENTER	Save selection to memory.		Press ENTER to save selection.
Press ▲ key	Scroll to menu exit.		
Press ENTER key	Return to Input Block.		
Press DISP key	Return to Display Mode.		Typical display mode.

Program Mode Continued

Reset Parameters to Factory Settings

Sometimes it is necessary to restore the parameter values to the factory settings. Follow this procedure to do so. Be sure to change the Level 2 Motor Data block "Motor Rated Amps" to the correct value after this procedure (restored factory setting is 999).

Note: All specific application parameters already programmed will be lost when resetting the control to factory settings.

Note: After factory settings are restored, the drive must be auto tuned.

Action	Description	Display	Comments
Apply Power	Keypad Display shows this opening message.	<pre>BALDOR MOTORS & DRIVES</pre>	Logo display for 5 seconds.
	If no faults and programmed for LOCAL operation.	<pre>STOP MOTOR SPEED LOCAL 0 RPM</pre>	Display mode. Stop LED on.
Press PROG key	Enter program mode.	<pre>PRESS ENTER FOR PRESET SPEEDS</pre>	
Press ▲ or ▼ key	Scroll to Level 2 Blocks.	<pre>PRESS ENTER FOR LEVEL 2 BLOCKS</pre>	
Press ENTER key	Select Level 2 Blocks.	<pre>PRESS ENTER FOR OUTPUT LIMITS</pre>	
Press ▲ or ▼ key	Scroll to the Miscellaneous block.	<pre>PRESS ENTER FOR MISCELLANEOUS</pre>	
Press ENTER key	Select Miscellaneous block.	<pre>RESTART AUTO/MAN P: MANUAL</pre>	
Press ▲ key	Scroll to Factory Settings parameter.	<pre>FACTORY SETTINGS P: NO</pre>	
Press ENTER key	Access Factory Settings parameter.	<pre>FACTORY SETTINGS \updownarrow <input type="checkbox"/> NO</pre>	<input type="checkbox"/> represents blinking cursor.
Press ▲ key	Scroll to YES, to choose original factory settings.	<pre>FACTORY SETTINGS \updownarrow <input type="checkbox"/> YES</pre>	
Press ENTER key	Restores factory settings.	<pre>FACTORY SETTINGS P:LOADING PRESETS</pre>	"Loading Presets" is first message "Operation Done" is next "No" is displayed last.
Press ▲ key	Scroll to menu exit.	<pre>PRESS ENTER FOR MENU EXIT</pre>	Exit Level 2 blocks.
Press ▲ or ▼ key	Scroll to Programming exit.	<pre>PRESS ENTER FOR PROGRAMMING EXIT</pre>	Exit Programming mode and return to Display mode.
Press ENTER key	Return to display mode.	<pre>STOP MOTOR SPEED LOCAL 0 RPM</pre>	Display mode. Stop LED on.

Program Mode Continued

Initialize New Firmware

After new firmware is installed, the control must be initialized to the new firmware version and memory locations. Use the following procedure to Initialize the firmware.

Action	Description	Display	Comments
Apply Power	Keypad Display shows this opening message.	<pre>BALDOR MOTORS & DRIVES</pre>	Logo display for 5 seconds.
	If no faults and programmed for LOCAL operation.	<pre>STOP MOTOR SPEED LOCAL 0 RPM</pre>	Display mode. Stop LED on.
Press PROG key	Enter program mode.	<pre>PRESS ENTER FOR PRESET SPEEDS</pre>	
Press ▲ or ▼ key	Scroll to Level 2 Blocks.	<pre>PRESS ENTER FOR LEVEL 2 BLOCKS</pre>	
Press ENTER key	Select Level 2 Blocks.	<pre>PRESS ENTER FOR OUTPUT LIMITS</pre>	
Press ▲ or ▼ key	Scroll to the Miscellaneous block.	<pre>PRESS ENTER FOR MISCELLANEOUS</pre>	
Press ENTER key	Select Miscellaneous block.	<pre>RESTART AUTO/MAN P: MANUAL</pre>	
Press ▲ key	Scroll to Factory Settings parameter.	<pre>FACTORY SETTINGS P: NO</pre>	
Press ENTER key	Access Factory Settings parameter.	<pre>FACTORY SETTINGS \updownarrow <input type="checkbox"/> NO</pre>	<input type="checkbox"/> represents blinking cursor.
Press ▲ key	Scroll to YES, to choose original factory settings.	<pre>FACTORY SETTINGS \updownarrow <input type="checkbox"/> YES</pre>	
Press ENTER key	Restores factory settings.	<pre>FACTORY SETTINGS P:LOADING PRESETS</pre>	"Loading Presets" is first message "Operation Done" is next "No" is displayed last.
Press ▲ key	Scroll to menu exit.	<pre>PRESS ENTER FOR MENU EXIT</pre>	
Press ENTER key	Return to display mode.	<pre>STOP MOTOR SPEED LOCAL 0 RPM</pre>	Display mode. Stop LED on.
Press DISP key several times	Scroll to diagnostic information screen.	<pre>PRESS ENTER FOR DIAGNOSTIC INFO</pre>	If you wish to verify the firmware version, enter diagnostic info.
Press ENTER key	Access diagnostic information.	<pre>STOP SPEED REF LOCAL 0 RPM</pre>	Displays commanded speed, direction of rotation, Local/Remote and motor speed.
Press DISP key	Display mode showing firmware version and revision installed in the control.	<pre>SOFTWARE VERSION SXX-X.XX</pre>	Verify new firmware version.
Press DISP key	Displays exit choice.	<pre>PRESS ENTER FOR DIAGNOSTIC EXIT</pre>	Press ENTER to exit diagnostic information.

Parameter Definitions

To make programming easier, parameters have been arranged into the two level structure shown in Table 3-1. Press the PROG key to enter the programming mode and the “Preset Speeds” programming block will be displayed. Use the Up (▲) and Down (▼) arrows to scroll through the parameter blocks. Press ENTER to access parameters within a programming block.

Tables 3-2 and 3-3 provide an explanation of each parameter. A complete Parameter Block Values list is located at the end of this manual. This list defines the programmable range and factory preset value for each parameter. The list has a space to record your settings for future reference.

Table 3-1 List of Parameters

LEVEL 1 BLOCKS		LEVEL 2 BLOCKS	LEVEL 2 BLOCKS
Preset Speeds	Input	Output Limits	Motor Data
Preset Speed #1	Operating Mode	Operating Zone	Armature Voltage
Preset Speed #2	Command Select	Min Output Speed	ARM Rated Amps
Preset Speed #3	ANA CMD Inverse	Max Output Speed	Motor Rated SPD
Preset Speed #4	ANA CMD Offset	PK Current Limit	Motor Field
Preset Speed #5	ANA 2 Deadband	CUR Rate Limit	Motor Field Volts
Preset Speed #6			Motor Field Amps
Preset Speed #7	Output		Feedback Type
Preset Speed #8	Opto Output #1	Custom Units	Encoder Counts
Preset Speed #9	Opto Output #2	Decimal Places	Resolver Speed
Preset Speed #10	Opto Output #3	Value at Speed	Tachometer Volts
Preset Speed #11	Opto Output #4	Units of Measure	PK Power Limit
Preset Speed #12	Zero SPD Set PT		
Preset Speed #13	At Speed Band	Protection	Process Control
Preset Speed #14	Set Speed	Overload	Process Feedback
Preset Speed #15	Analog Out #1	External Trip	Process Inverse
	Analog Out #2	Following Error	Setpoint Source
Accel / Decel Rate	Analog #1 Scale	Torque Proving	Setpoint Command
Accel Time #1	Analog #2 Scale		Set PT ADJ Limit
Decel Time #1	Position Band	Miscellaneous	Process ERR TOL
S-Curve #1		Restart Auto/Man	Process PROP Gain
Accel Time #2	DC Control	Restart Fault/Hr	Process INT Gain
Decel Time #2	Ctrl Base Volts	Restart Delay	Process DIFF Gain
S-Curve #2	Feedback Filter	Factory Settings	Follow I:O Ratio
	Feedback Dir	Homing Speed	Follow I:O Out
Jog Settings	ARM PROP Gain	Homing Offset	Master Encoder
Jog Speed	ARM INT Gain		
Jog Accel Time	Speed PROP Gain	Security Control	Auto-Tuning
Jog Decel Time	Speed INT Gain	Security State	CALC Presets
Jog S-Curve Time	Speed DIFF Gain	Access Timeout	CMD Offset Trim
	Position Gain	Access Code	CUR Loop Comp
Keypad Setup	IR COMP Gain		Feedback Tests
Keypad Stop Key	TACH Trim		SPD CNTRLR CALC
Keypad Stop Mode	Null Force Gain		
Keypad Run Fwd			
Keypad Run Rev	Field Control		
Keypad Jog Fwd	Field PWR Supply		
Keypad Jog Rev	Field ECON Level		
	Forcing Level		
	Field Set Speed		
	Field Step Limit		
	Field REG Gain		

Table 3-2 Level 1 Parameter Block Definitions

Block Title	Parameter	Description
PRESET SPEEDS	Preset Speeds #1 – #15	Allows selection of 15 predefined motor operating speeds. Each speed may be selected using external switches connected to J1-11, J1-12, J1-13 and J1-14 when Operating Mode is set to 15 Speed. For motor operation, a motor direction command must be given along with a preset speed command.
ACCEL/DECCEL RATE	Accel Time #1,2 Decel Time #1,2 S-Curve #1,2	<p>Accel time is the number of seconds required for the motor to increase at a linear rate from 0 RPM to the RPM specified in the "Max Output Speed" parameter in the Level 2 Output Limits block.</p> <p>Decel time is the number of seconds required for the motor to decrease at a linear rate from the speed specified in the "Max Output Speed" parameter to 0 RPM.</p> <p>S-Curve is a percentage of the total Accel and Decel time and provides smooth starts and stops. Half of programmed S-Curve % applies to Accel and half to Decel ramps. 0% represents no "S" and 100% represents full "S" with no linear segment.</p> <p>Note: Accel #1, Decel #1 and S-Curve #1 are associated together. Likewise, Accel #2, Decel #2 and S-Curve #2 are associated together. These associations can be used to control any Preset Speed or External Speed command.</p> <p>Note: If drive faults occur during rapid Accel or Decel, selecting an S-curve may eliminate the faults.</p>
JOG SETTINGS	Jog Speed Jog Accel Time Jog Decel Time Jog S-Curve	<p>Jog Speed is the programmed speed used during for jog. Jog can be initiated from the keypad or terminal strip. At the Keypad, press the JOG key then press and hold the direction (FWD or REV). At the terminal strip, close the direction input (J1-9 or J1-10) then close the JOG input (J1-12).</p> <p>To cause motor to operate at Jog Speed the FWD or REV key must be pressed and held or external command Forward (J1-9) or Reverse (J1-10).</p> <p>Jog Accel Time changes the Accel Time to a new preset value for jog mode.</p> <p>Jog Decel Time changes the Decel Time to a new preset value for jog mode.</p> <p>Jog S-Curve changes the S-Curve to a new preset value for jog mode.</p>

Figure 3-2 40% S-Curve Example



Table 3-2 Level 1 Parameter Block Definitions - Continued

Block Title	Parameter	Description
KEYPAD SETUP	Keypad Stop Key	Stop Key - Allows keypad "STOP" key to initiate motor stop during remote or serial operation (if Stop key is set to Remote ON). If active, pressing "STOP" automatically selects Local mode and initiates the stop command.
	Keypad Stop Mode	Stop Mode - Selects if the Stop command causes the motor to "COAST" to a stop or "REGEN" to a stop. In COAST, the motor is turned off and allowed to coast to a stop. In REGEN, the voltage and frequency to the motor is reduced at a rate set by "Decel Time".
	Keypad Run FWD	Run FWD - ON makes the keypad "FWD" key active in Local mode.
	Keypad Run REV	Run REV - ON makes the keypad "REV" key active in Local mode.
	Keypad Jog FWD	Jog FWD - ON makes the keypad "FWD" key active in Local Jog mode.
	Keypad Jog REV	Jog REV - ON makes the keypad "REV" key active in Local Jog mode.
		Note: The Series 19H is a uni-directional DC SCR control and does not have line regen capability. Therefore, direction reversal and dynamic braking must be added using optional hardware. Reversing contactor is described in the Opto Output description of Section 2. Contact your Baldor district office for information regarding the dynamic brake resistors.
INPUT	Operating Mode	Six "Operating Modes" are available. Choices are: Keypad, Standard Run, 15SPD, Serial, Bipolar, and Process. External connections to the control are made at the J1 terminal strip (wiring diagrams are shown in Section 2 "Control Circuit Connections").
	Command Select	Selects the external speed reference to be used. The easiest method of speed control is to select POTENTIOMETER and connect a 5KΩ pot to J1-1, J1-2, and J1-3. ±5, ±10VDC or 4-20mA input command can be applied to J1-4 and J1-5. If long distance is required between the external speed control and the control, the 4-20mA selections at J1-4 and J1-5 should be considered. Current loop allows long cable lengths without attenuation of the command signal. 10VOLT W/EXT CL - when a 10V differential command is present at J1-4 and 5, allows an additional 5V input at J1-1, 2 and 3 which allows reduction in programmed current limit for torque trimming during operation. 10 VOLT W/TORQ FF - when a differential command is present at J1-4 and 5, allows additional 5V torque feedforward input at J1-1, 2 and 3 to set a predetermined amount of torque inside the rate loop with high gain settings. EXB PULSE FOL - selects optional Master Pulse Reference/Isolated Pulse Follower expansion board if installed. 10VOLT EXB - selects optional High Resolution I/O expansion board if installed. 3-15 PSI EXB selects optional 3-15 PSI expansion board if installed. Tachometer EXB- selects optional DC Tachometer expansion board if installed. Serial -selects optional Serial Communications expansion board if installed. Note: When using the 4-20mA input, the JP1 jumper on the main control board must be moved to the left two pins "A".
	ANA CMD Inverse	"OFF" will cause a low input voltage (e.g. 0VDC) to be a low motor speed command and a maximum input voltage (e.g. 10VDC) to be a maximum motor speed command. "ON" will cause a low input voltage (e.g. 0VDC) to be a maximum motor speed command and a maximum input voltage (e.g. 10VDC) to be a low motor speed command.
	ANA CMD Offset	Provides an offset to the Analog Input to minimize signal drift. For example, if the minimum speed signal is 1VDC (instead of 0VDC) the ANA CMD Offset can be set to -10% so the minimum voltage input is seen by control as 0VDC.
	ANA 2 Deadband	Allows a voltage threshold to be defined. A command signal level below this voltage will not affect the control output.

Table 3-2 Level 1 Parameter Block Definitions - Continued

Block Title	Parameter	Description																																						
OUTPUT	OPTO OUTPUT #1 – #4	<p>Four optically isolated digital outputs that have two operating states, logical High or Low. Each output may be configured to any of the following conditions:</p> <table border="0"> <thead> <tr> <th data-bbox="662 373 781 401">Condition</th> <th data-bbox="873 373 992 401">Description</th> </tr> </thead> <tbody> <tr> <td data-bbox="662 415 748 443">Ready -</td> <td data-bbox="873 415 1458 443">Active when power is applied and no faults are present.</td> </tr> <tr> <td data-bbox="662 449 805 476">Zero Speed -</td> <td data-bbox="873 449 1544 504">Active when output frequency to motor is below the value of the Level 1 Output “Zero SPD Set Pt” parameter.</td> </tr> <tr> <td data-bbox="662 510 776 537">At Speed -</td> <td data-bbox="873 510 1539 564">Active when output speed is within the speed range defined by the Level 1 Output “At Speed Band” parameter.</td> </tr> <tr> <td data-bbox="662 571 821 598">At Set Speed -</td> <td data-bbox="873 571 1500 625">Active when output speed is at or above the Level 1 Output “Set Speed” parameter.</td> </tr> <tr> <td data-bbox="662 632 776 659">Overload -</td> <td data-bbox="873 632 1490 716">A normally closed contact that is active (opens) during an Overload fault caused by a time out when output current is greater than Rated Current.</td> </tr> <tr> <td data-bbox="662 722 846 749">Keypad Control -</td> <td data-bbox="873 722 1360 749">Active when control is in Local keypad control.</td> </tr> <tr> <td data-bbox="662 756 732 783">Fault -</td> <td data-bbox="873 756 1295 783">Active when a fault condition is present.</td> </tr> <tr> <td data-bbox="662 789 837 816">Following ERR -</td> <td data-bbox="873 789 1484 844">Active when the motor speed is outside the user specified tolerance band defined by the At Speed Band parameter.</td> </tr> <tr> <td data-bbox="662 850 841 877">Motor Direction -</td> <td data-bbox="873 850 1555 905">Active High when REV direction command received. Active Low when FWD direction command received.</td> </tr> <tr> <td data-bbox="662 911 776 938">Drive On -</td> <td data-bbox="873 911 1344 938">Active when control is Enabled and “Ready”.</td> </tr> <tr> <td data-bbox="662 945 834 972">CMD Direction -</td> <td data-bbox="873 945 1565 1008">Active at all times. Logical output state indicates Forward (Open) or Reverse (Closed) direction.</td> </tr> <tr> <td data-bbox="662 1014 802 1041">AT Position -</td> <td data-bbox="873 1014 1539 1077">Active during a positioning command when control is within the position band parameter tolerance.</td> </tr> <tr> <td data-bbox="662 1083 857 1110">Over Temp Warn -</td> <td data-bbox="873 1083 1500 1110">Active when control heat sink is within 3°C of Int Overtemp.</td> </tr> <tr> <td data-bbox="662 1117 824 1144">Process Error -</td> <td data-bbox="873 1117 1565 1201">Active when process feedback signal is outside the range specified by the Level 2 Process Control block, AT Setpoint Band parameter. Turns off when process feedback error is eliminated.</td> </tr> <tr> <td data-bbox="662 1207 786 1234">Drive Run -</td> <td data-bbox="873 1207 1565 1262">Active when drive is Ready, Enabled, Speed or Torque command received with FWD/REV direction issued.</td> </tr> <tr> <td data-bbox="662 1268 824 1295">Running Field -</td> <td data-bbox="873 1268 1555 1352">Active when field current is greater than 90% of the user programmed motor field amps. Could be used as a torque ready output.</td> </tr> <tr> <td data-bbox="662 1358 850 1386">M/FWD Contact -</td> <td data-bbox="873 1358 1565 1568">May be used to close an external motor armature contactor. This output is high when the control is ready and a forward or reverse command is issued. There is a 16ms delay between M/FWD CONTACT ON and when the control actually engages the output bridge. The delay helps compensate for any contactor bounce. The output turns OFF when forward and reverse are dropped and after the armature current is reduced to zero. Refer to Opto Output description of Section 2.</td> </tr> <tr> <td data-bbox="662 1575 818 1602">REV Contact -</td> <td data-bbox="873 1575 1555 1680">Active when reverse motor direction is commanded. When selected feedback direction is assumed to have changed in ARM–FDBK, A1–A2 voltage sense wires must be brought out to motor leads. Refer to Opto Output description of Section 2.</td> </tr> </tbody> </table>	Condition	Description	Ready -	Active when power is applied and no faults are present.	Zero Speed -	Active when output frequency to motor is below the value of the Level 1 Output “Zero SPD Set Pt” parameter.	At Speed -	Active when output speed is within the speed range defined by the Level 1 Output “At Speed Band” parameter.	At Set Speed -	Active when output speed is at or above the Level 1 Output “Set Speed” parameter.	Overload -	A normally closed contact that is active (opens) during an Overload fault caused by a time out when output current is greater than Rated Current.	Keypad Control -	Active when control is in Local keypad control.	Fault -	Active when a fault condition is present.	Following ERR -	Active when the motor speed is outside the user specified tolerance band defined by the At Speed Band parameter.	Motor Direction -	Active High when REV direction command received. Active Low when FWD direction command received.	Drive On -	Active when control is Enabled and “Ready”.	CMD Direction -	Active at all times. Logical output state indicates Forward (Open) or Reverse (Closed) direction.	AT Position -	Active during a positioning command when control is within the position band parameter tolerance.	Over Temp Warn -	Active when control heat sink is within 3°C of Int Overtemp.	Process Error -	Active when process feedback signal is outside the range specified by the Level 2 Process Control block, AT Setpoint Band parameter. Turns off when process feedback error is eliminated.	Drive Run -	Active when drive is Ready, Enabled, Speed or Torque command received with FWD/REV direction issued.	Running Field -	Active when field current is greater than 90% of the user programmed motor field amps. Could be used as a torque ready output.	M/FWD Contact -	May be used to close an external motor armature contactor. This output is high when the control is ready and a forward or reverse command is issued. There is a 16ms delay between M/FWD CONTACT ON and when the control actually engages the output bridge. The delay helps compensate for any contactor bounce. The output turns OFF when forward and reverse are dropped and after the armature current is reduced to zero. Refer to Opto Output description of Section 2.	REV Contact -	Active when reverse motor direction is commanded. When selected feedback direction is assumed to have changed in ARM–FDBK, A1–A2 voltage sense wires must be brought out to motor leads. Refer to Opto Output description of Section 2.
Condition	Description																																							
Ready -	Active when power is applied and no faults are present.																																							
Zero Speed -	Active when output frequency to motor is below the value of the Level 1 Output “Zero SPD Set Pt” parameter.																																							
At Speed -	Active when output speed is within the speed range defined by the Level 1 Output “At Speed Band” parameter.																																							
At Set Speed -	Active when output speed is at or above the Level 1 Output “Set Speed” parameter.																																							
Overload -	A normally closed contact that is active (opens) during an Overload fault caused by a time out when output current is greater than Rated Current.																																							
Keypad Control -	Active when control is in Local keypad control.																																							
Fault -	Active when a fault condition is present.																																							
Following ERR -	Active when the motor speed is outside the user specified tolerance band defined by the At Speed Band parameter.																																							
Motor Direction -	Active High when REV direction command received. Active Low when FWD direction command received.																																							
Drive On -	Active when control is Enabled and “Ready”.																																							
CMD Direction -	Active at all times. Logical output state indicates Forward (Open) or Reverse (Closed) direction.																																							
AT Position -	Active during a positioning command when control is within the position band parameter tolerance.																																							
Over Temp Warn -	Active when control heat sink is within 3°C of Int Overtemp.																																							
Process Error -	Active when process feedback signal is outside the range specified by the Level 2 Process Control block, AT Setpoint Band parameter. Turns off when process feedback error is eliminated.																																							
Drive Run -	Active when drive is Ready, Enabled, Speed or Torque command received with FWD/REV direction issued.																																							
Running Field -	Active when field current is greater than 90% of the user programmed motor field amps. Could be used as a torque ready output.																																							
M/FWD Contact -	May be used to close an external motor armature contactor. This output is high when the control is ready and a forward or reverse command is issued. There is a 16ms delay between M/FWD CONTACT ON and when the control actually engages the output bridge. The delay helps compensate for any contactor bounce. The output turns OFF when forward and reverse are dropped and after the armature current is reduced to zero. Refer to Opto Output description of Section 2.																																							
REV Contact -	Active when reverse motor direction is commanded. When selected feedback direction is assumed to have changed in ARM–FDBK, A1–A2 voltage sense wires must be brought out to motor leads. Refer to Opto Output description of Section 2.																																							

Table 3-2 Level 1 Parameter Block Definitions - Continued

Block Title	Parameter	Description
OUTPUT (Continued)	Zero SPD Set PT	Sets the speed at which the Zero Speed opto output becomes active (turns on). When the speed is less than the ZERO SPD SET PT, the Opto Output becomes active. This is useful when a motor brake is to interlock operation with a motor.
	At Speed Band	The At Speed Band serves two Opto Output Conditions and the Level 2 Protection block Following Error: Sets the speed range in RPM at which the At Speed opto output turns on and remains active within the range. Sets the Following Error Tolerance Band for the Level 1 OUTPUT, Opto Output condition Following ERR. The opto output is active if the motor speed is outside this band. Sets the no fault operating speed range of the drive. This value is used by the Level 2 Protection block, Following Error parameter (if it is set to ON). If the drive speed falls out of this band, the Level 2 Protection block, Following Error parameter will shut down the drive (if it is set to ON).
	Set Speed	Sets the speed that the AT Set Speed opto output becomes active (turns on). When the speed is greater than the Level 1 Output SET SPEED parameter, the Opto Output becomes active. This is useful when another machine must not start or stop until the motor exceeds a predetermined speed.
	Analog Output #1 and #2	Two Analog 0-5VDC linear outputs may be configured to represent any of 19 conditions as follows: Condition Description ABS Speed - Represents the absolute motor speed where 0VDC = 0 RPM and +5VDC = MAX RPM. ABS Torque - Represents the absolute value of torque where +5VDC = Torque at CURRENT LIMIT. The absolute torque output is scaled by the torque constant. The torque constant or torque per armature amp drops as the field current drops. Thus, in field weakening the torque output remains accurate. Useful as a load meter output. ABS Speed - Command Represents the absolute value of commanded speed where +5VDC = MAX RPM. Field Current - 5 VDC = max. supply amps (e.g. 5V = 15 amps for a 15 amp field power supply). CMD Field CUR - 5 VDC = max supply amps. ARM Current - 2.5 VDC = 0.0, +5 VDC = + current limit, 0 VDC = - current limit. CMD ARM CUR - 2.5 VDC = 0.0, +5 VDC = + current limit, 0 VDC = - current limit. Firing Angle - Firing angle scaled +2.5 V = 0. 0V = max regen. +5V = MAX ADVANCE. ARM Volts - Arm volts scaled 2.5V = 0, 0V = \square Field Volts - Field volts, 4 volts = RATED FIELD VOLTAGE. Torque - Bipolar torque output. 2.5V centered, 5V = Max Positive Torque, 0V = Max negative torque. Power - Bipolar power output. 2.5V = Zero Power, 0V = negative rated peak power, +5V = Positive rated peak power. Velocity - Represents motor speed scaled to 0V = negative max RPM, +2.5V = Zero Speed, +5V = positive max RPM. Overload - (Accumulated current) ² x (time), Overload occurs at +5V. (I ² t) Position - Position within a single revolution. +5V = 1 complete revolution. The counter will reset to 0 every revolution. Line Timer - Internally used square wave form, phase locked to L1-L2.
	Analog Scale #1 & #2	Scale factor for the Analog Output voltage. Useful to set the zero value or full scale range for external meters.
	Position Band	Sets the acceptable range in digital counts (pulses) at which the AT Position Opto becomes active (turns on).

Table 3-2 Level 1 Parameter Block Definitions - Continued

Block Title	Parameter	Description
DC Control	CTRL BASE Volts	This sets the armature voltage where the control begins to go into "field weakening" to achieve higher speeds from the motor (not available with armature feedback). Chooses lowest voltage between ARMATURE VOLTAGE, 130% of Line Voltage, or the manual setting for CTRL BASE VOLTS. Adjustable range is 0–1000V.
	Feedback Filter	Sets the number of scans by the control's microprocessor to filter the encoder input signal. It is automatically set to suit the encoder resolution during the Auto Tuning function. A larger value provides a more filtered signal but at the cost of reduced bandwidth. A smaller value provides smoother low speed operation.
	Feedback DIR	Sets the encoder's electrical direction of rotation to match that of the motor.
	ARM PROP Gain	Sets the current loop proportional gain.
	ARM INT Gain	Sets the current loop integral gain.
	Speed PROP Gain	Sets the speed (velocity) loop proportional gain.
	Speed INT Gain	Sets the speed (velocity) loop integral gain.
	Speed DIFF Gain	Sets the speed (velocity) loop differential gain.
	Position Gain	Sets the position loop proportional gain.
	IR COMP Gain (See Note 1)	Sets gain for armature resistance compensation. Used for armature feedback only. When using armature feedback, begin with a setting of 50 and adjust as needed for removal of speed error (No-Load/Load), smoothness and stability.
	TACH Trim	Scales tachometer voltage to compensate for individual tach voltage scale factor.
Null Force Gain	Adjusts small signal current loop response relative to changes in firing angle. Helps current loop response to be nominal over the entire current range of the control, particularly at light loads.	

Note 1: For Armature Feedback, the IR COMP Gain adjustment compensates for the armature voltage drop. Excessive IR COMP Gain may cause motor speed to become erratic. For Shunt wound motors have a rising speed characteristic where speed increases with load and may not be suitable for armature feedback. Instead, Tachometer or Encoder feedback should be used for these shunt wound applications. Stabilized shunt wound motors have a very flat speed/torque characteristic and work well with armature feedback.

To set IR COMP Gain:

1. Run motor at base speed with no load. Measure RPM with hand held tachometer and record the RPM.
(Do not rely on the RPM display of the control as it may not be accurate with armature feedback.)
2. Run motor at base speed with full load. Measure RPM with hand held tachometer and record the RPM.
3. Adjust IR COMP Gain 5 units.
4. Repeat steps 1 to 3 until no load speed (step 1) and full load speed (step 2) are matched.

Table 3-2 Level 1 Parameter Block Definitions - Continued

Block Title	Parameter	Description
Field Control	Field PWR Supply	This is used to select the type of field power supply used with the control. The standard power supply can supply up to 15 amps for shunt wound motors. If using permanent magnet motors, the field power supply may be disabled by selecting NONE. If the shunt wound motor requires more than 15 amps for its field, an optional 40 amp field power supply may be added.
	Field ECON Level	Sets the field voltage applied to the motor during stand-still while the control is disabled. This is used to keep the fields warm to ensure the motor can run to its base speed. Field economy is also often used instead of a space heater. Excessive voltage may cause the field to overheat resulting in premature motor failure. Any value less than 25% (or 100 mA) causes the field economy circuit to be off when disabled and automatically set to 0%.
	Forcing Level	This setting is often used in the hoist mode to over saturate the fields causing a soft start or stop. Only available in Series 20H Line Regen controls and used in BIPOLAR HOIST and 7 SPEED HOIST modes.
	Field Set Speed	This sets the speed at which the field voltage is switched from the Forcing Level to the standard field run voltage. Only available in Series 20H Line Regen controls.
	Field Step Limit	This sets the ramp rate time when changing from field levels (field force voltage to standard run voltage). Only available in Series 20H Line Regen controls.
	Field REG Gain	This sets the proportional gain in the field current control.
LEVEL 2 BLOCK		ENTERS LEVEL 2 MENU

Figure 3-3 Relationship of Field Control Parameters

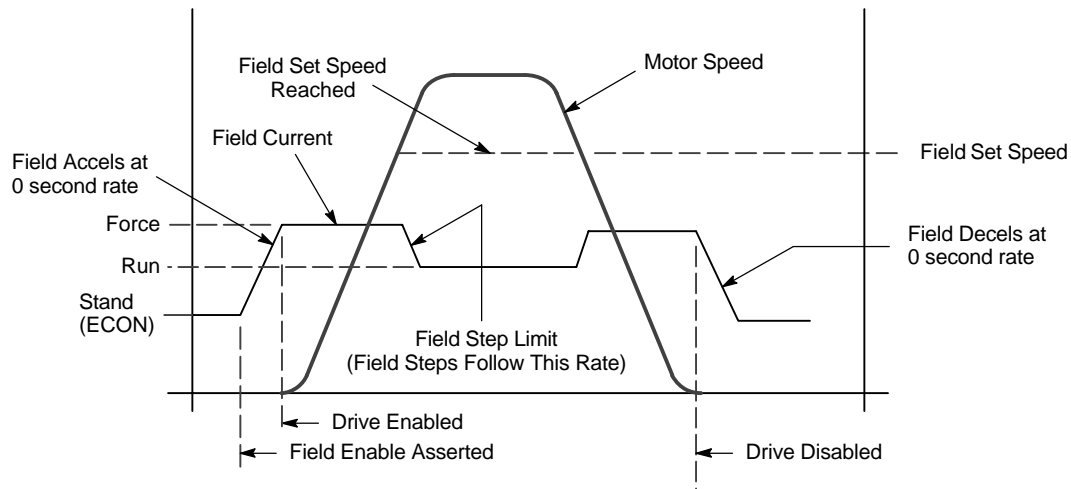

Field Forcing, Field Set Speed and Field Step Limit parameters are not active with Series 19H controls. These parameters are only active for Series 20H Line Regen controls when operated in the Bipolar Hoist or 7 Speed Hoist modes.

Table 3-3 Level 2 Parameter Block Definitions

Block Title	Parameter	Description
OUTPUT LIMITS	Operating Zone	Sets the operating zone to One Way (Non Line Regenerative).
	MIN Output Speed	Sets the minimum motor speed in RPM. During operation, the motor speed will not be allowed to go below this value except for motor starts from 0 RPM.
	MAX Output Speed	Sets the maximum motor speed in RPM.
	PK Current Limit	The maximum output peak current to the motor. Values above 100% of the rated current are available depending upon the operating zone selected.
	CUR Rate Limit	Limits the motor inrush current to protect the motor commutator.
CUSTOM UNITS	Decimal Places	The number of decimal places of the Output Rate display on the Keypad display. This value will be automatically reduced for large values. The output rate display is only available if the Value At Speed parameter value is non zero.
	Value At Speed	Sets the desired output rate per RPM of motor speed. Two numbers are displayed on the keypad display (separated by a slash "/"). The first number (left most) is the value you want the keypad to display at a specific motor speed. The second number (right most) is the motor RPM corresponding to the units in the first number. A decimal may be inserted into the numbers by placing the flashing cursor over the up/down arrow.
	Units of Measure	Allows user specified units of measure to be displayed on the Output Rate display. Use the shift and arrow keys to scroll to the first and successive characters. If the character you want is not displayed, move the flashing cursor over the special up/down character arrow on the left side of the display. Use the up/down arrows and the shift key to scroll through all 9 character sets. Use the ENTER key to save your selection.
PROTECTION	Overload	Sets the protection mode to Fault (trip off during overload condition) or to Foldback (automatically reduce the output current below the continuous output level) during an overload. Foldback is the choice if continuous operation is desired. Fault will require the control be "Reset" after an overload.
	External Trip	OFF - External Trip is Disabled. ON - External Trip is enabled. If a normally closed contact at J1-16 is opened, an External Trip fault will occur and cause the drive to shut down.
	Following Error	This parameter determines if the control is to monitor the amount of following error that occurs in an application. Following Error is the programmable tolerance for the AT Speed Opto output as defined by the Level 1 Output block, AT Speed Band parameter. Operation outside the speed range will cause a fault and the drive will shut down.
	Torque Proving	When this parameter is set to ON the control tests for armature circuit continuity for a 20ms period. It indicates a torque proving fault if sufficient current is not sensed. This feature is useful in many applications to ensure torque is being applied. In a hoist, for example, torque proving could be used to make sure torque exists before a brake is released. "Drive On" output, if programmed, will not occur if torque proving fails. Available settings are On and OFF. Factory setting is OFF.

⚠ Caution: If an automatic restart of the motor control could cause injury to personnel, the automatic restart feature should be disabled by changing the Level 2 Miscellaneous block, Restart Auto/Man parameter to manual.

Table 3-3 Level 2 Parameter Block Definitions Continued

Block Title	Parameter	Description
MISCELLANEOUS	Restart Auto/Man	Manual - If a fault or power loss occurs, the control must be manually reset to resume operation. Automatic - If a fault or power loss occurs, the control will automatically reset to resume operation.
	Restart Fault/Hr	The maximum number of automatic restart attempts before requiring a manual restart. After one hour without reaching the maximum number of faults or if power is turned off and on again, the fault count is reset to zero.
	Restart Delay	The amount of time allowed after a fault condition for an automatic restart to occur. Useful to allow sufficient time to clear a fault before restart is attempted.
	Factory Settings	Restores factory settings for all parameter values. Select YES and press "ENTER" key to restore factory parameter values. The keypad Display will show "Operation Done" then return to "NO" when completed. Note: When factory settings are reset, the Motor Rated Amps value is reset to 999.9 amps. This Level 2 Motor Data block parameter value must be changed to the correct value (located on the motor rating plate) before attempting to start the drive and auto tune.
	Homing Speed	In Bipolar and Serial modes, this parameter sets the speed that the motor shaft will rotate to a "Home" position when the orient input switch is closed (J1-11).
	Homing Offset	In Bipolar and Serial modes, this parameter sets the number of digital encoder counts past home at which the motor stop command is issued. Quadrature encoder pulses are 4 times the number of encoder lines per revolution. The recommended minimum number is 100 encoder counts to allow for deceleration distance to allow the motor to stop smoothly. Note: Homing direction is always forward.

Table 3-3 Level 2 Parameter Block Definitions Continued

Block Title	Parameter	Description
SECURITY CONTROL	Security State	<p>Off - No security Access Code required to change parameter values. Local - Requires security Access Code to be entered before changes can be made using the Keypad. Serial - Requires security Access Code to be entered before changes can be made using the Serial Link. Total - Requires security Access Code to be entered before changes can be made using the Keypad or serial link.</p> <p>Note: If security is set to Local, Serial or Total you can press PROG and scroll through the parameter values that are programmed but you are not allowed to change them unless you enter the correct access code.</p>
	Access Timeout	The time in seconds the security access remains enabled after leaving the programming mode. If you exit and go back into the program Mode within this time limit, the security Access Code does not have to be re-entered. This timer starts when leaving the Program Mode (by pressing DISP).
	Access Code	<p>A 4 digit number code. Only persons that know the code can change secured Level 1 and Level 2 parameter values.</p> <p>Note: Please record your access code and store it in a safe place. If you cannot gain entry into parameter values to change a protected parameter, please contact Baldor. Be prepared to give the 5 digit code shown on the lower right side of the Keypad Display at the Security Control Access Code parameter prompt.</p>
MOTOR DATA	Armature Voltage	The rated Armature voltage of the motor (listed on the motor nameplate).
	ARM Rated Amps	The rated armature current of the motor (listed on the motor nameplate). If the motor current exceeds this value for a period of time, an Overload fault will occur.
	Motor Rated SPD	The rated speed of the motor (listed on the motor nameplate). In the case of wound field motor nameplates, speed may be indicated as Base Speed/Max Field Weakened Speed. The base speed is entered in the MOTOR RATED SPD parameter. The Max Field Weakened Speed may be entered in the MAXIMUM OUTPUT SPEED parameter located in the Output Limits block, if operation faster than base speed is desired.
	Motor Field	This indicates the type of field in the motor. Available settings are Shunt and Permanent Magnet.
	Motor Field Amps	The rated field amps of the motor for base speed operation and based on the connections you have made. Many motors have a dual voltage field. This is stated on the motor nameplate or shown in the motor connection diagram. The standard field supply for controls up to 300HP is 15 Amps. An optional 40 Amp field supply is available for dual voltage field motors and for controls that are 400HP and larger. If the field current drops to less than 0.15A, a Field Loss Fault will be displayed by the control.
	Feedback Type	This designates the type of feedback used by the control. The control's standard feedback options are ENCODER and ARMATURE. Specify ARMATURE if the control is operated open loop and start with the IR Comp Gain set to 50. DC tachometer and resolver feedback are available with the appropriate optional expansion boards. Feedback device must be coupled to the motor shaft or at a 1:1 ratio.
	Encoder Counts	The number of counts (pulses) per revolution, if an encoder is feedback type.
	Resolver Speed	The speed of the resolver, if a resolver is used for feedback type. The parameter is only active when the optional Resolver to Digital expansion board is installed.
	Tachometer Volts	The DC volts per 1000 RPM output of the tachometer (V/KRPM). The parameter is only active when the optional tachometer feedback expansion board is installed.
	PK Power Limit	This setting is often used as a commutation limiter in permanent magnet servo motors to set the peak current for commutation limits. This parameter is only active when PERM MAGNET is selected for motor field type.
	CALC Presets	This procedure loads preset values into memory that are required to perform Auto Tune. Always run CALC Presets as the first step of Auto Tune.

Table 3-3 Level 2 Parameter Block Definitions Continued

Block Title	Parameter	Description
PROCESS CONTROL	Process Feedback	Sets the type of signal used for the process feedback signal.
	Process Inverse	Causes the process feedback signal to be inverted. Used with reverse acting processes that use a unipolar signal such as 4-20mA. If "ON", 20mA will decrease motor speed and 4mA will increase motor speed.
	Setpoint Source	Sets the source input signal type to which the process feedback will be compared. If "Setpoint CMD" is selected, the fixed value of the set point is entered in the Setpoint Command parameter value.
	Setpoint Command	Sets the value of the setpoint the control will try to maintain by adjusting motor speed. This is only used when the Setpoint Source is a fixed value "Setpoint CMD" under Setpoint Source.
	Set PT ADJ Limit	Sets the maximum speed correction value to be applied to the motor (in response to the maximum feedback setpoint error). For example, if the max motor speed is 1750 RPM, the setpoint feedback error is 100% and the setpoint adjustment limit is 10%, the maximum speed the motor will run in response to the setpoint feedback error is ± 175 RPM. If at the process setpoint, the motor speed is 1500 RPM, the maximum speed adj limits is then 1325 to 1675 RPM.
	Process ERR TOL	Sets the width of the comparison band (% of setpoint) with which the process input is compared. The result is that if the process input is within the comparison band the corresponding Opto Output will become active.
	Process PROP Gain	Sets the PID loop proportional gain. This determines how much adjustment to motor speed (within the Set PT ADJ Limit) is made to move the analog input to the setpoint.
	Process INT Gain	Sets the PID loop Integral gain. This determines how quickly the motor speed is adjusted to correct long term error.
	Process DIFF Gain	Sets the PID loop differential gain. This determines how much adjustment to motor speed (within the Set PT ADJ Limit) is made for transient error.
	Follow I:O Ratio	Sets the ratio of the Master to the Follower in Master/Follower configurations. Requires the Master Pulse Reference/ Isolated Pulse Follower expansion board. For example, the master encoder you want to follow is a 1024 count encoder. The follower motor you wish to control also has a 1024 count encoder on it. If you wish the follower to run twice the speed of the master, a 1:2 ratio is entered. Fractional ratios such as 0.5:1 are entered as 1:2. Ratio limits are 65,535:1 to 1:20. Note: The Master Encoder parameter must be defined if a value is entered in the Follow I:O Ratio parameter. Note: When using Serial Communications to operate the control, this value is the MASTER portion of the ratio. The FOLLOWER portion of the ratio is set in the Follow I:O Out parameter.
	Follow I:O Out	This parameter is used only when Serial Communications is used to operate the control. A Master Pulse Reference/ Isolated Pulse Follower expansion board is required. This parameter represents the FOLLOWER portion of the ratio. The MASTER portion of the ratio is set in the Follow I:O Ratio parameter.
	Master Encoder	Only used if an optional Master Pulse Reference/Isolated Pulse Follower expansion board is installed. Defines the number of pulses per revolution of the master encoder. Only used for follower drives.

Section 4 Troubleshooting





The Baldor Series 19H Control requires very little maintenance and should provide years of trouble free operation when installed and applied correctly. Occasional visual inspection should be considered to ensure tight wiring connections and to avoid the build up of any dust, dirt, or foreign debris which can reduce heat dissipation.

Before attempting to service this equipment, all input power must be removed from the control to avoid the possibility of electrical shock. The servicing of this equipment should be handled by a qualified electrical service technician experienced in the area of high power electronics.





It is important to familiarize yourself with the following information before attempting any troubleshooting or service of the control. Most troubleshooting can be performed using only a digital voltmeter having an input impedance exceeding 1 meg Ohm. In some cases, an oscilloscope with 5 MHZ minimum bandwidth may be useful. Before consulting the factory, check that all power and control wiring is correct and installed per the recommendations given in this manual.

No Keypad Display - Display Contrast Adjustment



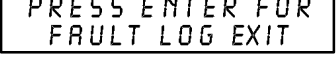
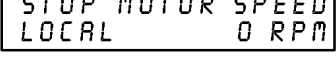

If there is no visible display, use the following procedure to adjust the contrast of the display.

Action	Description	Display	Comments
Apply Power	No visible display.		Display mode.
Press DISP key	Ensures control in Display mode.		
Press SHIFT key 2 times	Allows display contrast adjustment.		
Press ▲ or ▼ key	Adjusts display contrast (intensity).		
Press ENTER key	Saves display contrast adjustment level and exits to display mode.		

How to Access the Fault Log When a fault condition occurs, motor operation stops and a fault code is displayed on the Keypad display. The control keeps a log of up to the last 31 faults. If more than 31 faults have occurred the oldest fault will be deleted from the fault log to make room for the newest fault. To access the fault log use the following procedure:

Action	Description	Display	Comments
Apply Power			Logo display for 5 seconds.
	Display mode showing output frequency		Display mode.
Press DISP key 5 times	Use DISP key to scroll to the Fault Log entry point.		
Press ENTER key	Display first fault type and time fault occurred.		Typical display.
Press ▲ key	Scroll through fault messages.		If no messages, the fault log exit choice is displayed.
Press ENTER key	Return to display mode.		Display mode stop key LED is on.

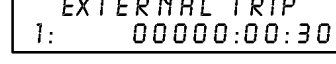
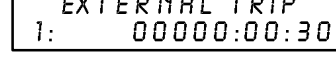
How to Clear the Fault Log Use the following procedure to clear the fault log.

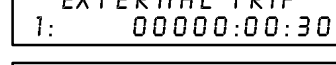
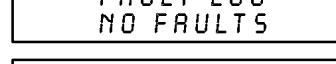
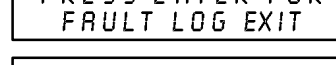
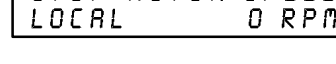
Action	Description	Display	Comments
Apply Power			Logo display for 5 seconds.
	Display mode showing output frequency.		Display mode.
Press DISP key	Press DISP to scroll to the Fault Log entry point.		
Press ENTER key	Displays most recent message.		
Press SHIFT key			
Press RESET key			
Press SHIFT key			
Press ENTER key	Fault log is cleared.		No faults in fault log.
Press ▲ or ▼ key	Scroll Fault Log Exit.		
Press ENTER key	Return to display mode.		

How to Access Diagnostic Information

Action	Description	Display	Comments
Apply Power		<pre>BALDOR MOTORS & DRIVES</pre>	Logo display for 5 seconds.
	Display mode showing motor speed.	<pre>STOP MOTOR SPEED LOCAL 0 RPM</pre>	No faults present. Local keypad mode. If in remote/serial mode, press local for this display.
Press DISP key 6 times	Scroll to Diagnostic Information screen	<pre>PRESS ENTER FOR DIAGNOSTIC INFO</pre>	Diagnostic Access screen.
Press ENTER key	Access diagnostic information.	<pre>STOP SPEED REF LOCAL 0 RPM</pre>	First Diagnostic Information screen.
Press DISP key	Display showing control temperature.	<pre>STOP CONTROL TEMP LOCAL 0.0° C</pre>	
Press DISP key	Display showing bus voltage.	<pre>STOP BUS VOLTAGE LOCAL XXXV</pre>	
Press DISP key	Display showing % overload current remaining.	<pre>STOP OVRLD LEFT LOCAL 100.00%</pre>	
Press DISP key	Display showing opto inputs & outputs states.	<pre>DIGITAL I/O 000000000 0000</pre>	Opto Inputs states (Left); Opto Outputs states (Right).
Press DISP key	Display showing actual drive running time.	<pre>TIME FROM PWR UP 0000000.01.43</pre>	HR.MIN.SEC format.
Press DISP key	Display showing operating zone, voltage and control type.	<pre>QUIET VAR TQ XXXV FLUX VECTOR</pre>	
Press DISP key	Display showing continuous amps; PK amps rating; amps/volt scale of feedback, power base ID.	<pre>X.XA X.X APK X.XX A/V ID:XXX</pre>	ID is displayed as a hexadecimal value.
Press DISP key	Display showing which Group1 or 2 expansion boards are installed.	<pre>G1 NOT INSTALLED G2 NOT INSTALLED</pre>	
Press DISP key	Display showing motor shaft revolutions from the REV home set point.	<pre>POSITION COUNTER + 000.00000 REV</pre>	
Press DISP key	Display showing software version and revision installed in the control.	<pre>SOFTWARE VERSION SXX-X.XX</pre>	
Press DISP key	Displays exit choice.	<pre>PRESS ENTER FOR DIAGNOSTIC EXIT</pre>	Press ENTER to exit diagnostic information.

Table 4-4 Troubleshooting

INDICATION	POSSIBLE CAUSE	CORRECTIVE ACTION
ARM VOLT Sense	The control has detected an excessive amount of armature feedback voltage on the armature during power-up.	The permanent magnet motor may be rotating on power-up.
	Excessive noise on cables.	Separate armature leads from any other power.
	Defective base ID board.	Call Baldor if problem remains.
Auto Tune Encoder Test failed	Encoder miswired.	Correct wiring problems.
	Encoder coupling slipping, broken or misaligned.	Correct encoder to motor coupling.
	Excessive noise on encoder lines.	Check the position counter in the Diagnostic Information for jittering which will confirm an encoder problem. Use recommended encoder cable. Check encoder connections including shields. Separate encoder leads from power wiring. Cross encoder cables and power leads at 90°. Electrically isolate encoder from motor. Install optional Isolated Encoder Feedback expansion board.
Check TACH Jumpers	Incorrect DC tach expansion board jumper settings.	User entered TACH VOLTS or MAX SPEED has changed the tach board jumper setting. Check tach board info in the DIAGNOSTICS DISPLAY, correct jumper settings. press RESET.
Current Sense FLT	Excessive armature current feedback.	Suspect ±15V supply fault, wiring between base ID and feedback boards, defective feedback board or board scaling.
Encoder Loss	Encoder power supply failure.	Check 5VDC at J1-29 and J1-30. Also check at encoder end pins D and F.
	Encoder coupling slipping, broken or misaligned	Correct or replace encoder to motor coupling.
	Excessive noise on encoder lines.	Check the position counter in the Diagnostic Information for jittering which will confirm an encoder problem. Check encoder connections. Separate encoder leads from power wiring. Cross encoder cables and power leads at 90°. Electrically isolate encoder from motor. Install optional Isolated Encoder Feedback expansion board.
TACH Loss	Tach coupling slipped or broken.	Check tach to motor coupling.
	Excessive noise on tach lines.	Check tach connections. Separate tach leads from power wiring. Cross power leads at 90°. Use shielded tach leads.
	Wrong jumper settings on DC TACH expansion board.	Check jumper selection based on tach output and MAX SPEED of motor. Reset at needed.
	DC Contactor may be open.	Check contactor.
Resolver Loss	Resolver coupling slipped or broken.	Check resolver to motor coupling.
	Incorrect connections to Resolver Feedback expansion board.	Check Resolver Feedback expansion board manual for correct wiring and parameters.
	Excessive noise on resolver lines.	Check resolver connections. Separate resolver leads from power wiring. Cross power leads at 90°. Use shielded resolver leads.

Table 4-4 Troubleshooting Continued

INDICATION	POSSIBLE CAUSE	CORRECTIVE ACTION
External Trip	Motor ventilation insufficient.	Clean motor air intake and exhaust. Check external blower for operation. Verify motor's internal fan is coupled securely.
	Motor draws excessive current.	Check motor for overloading. Verify proper sizing of control and motor.
	No thermostat connected.	Connect thermostat. Verify connection of all external trip circuits used with thermostat. Disable thermostat input at J1-16 (External Trip Input).
	Poor thermostat connections.	Check thermostat connections.
	External trip parameter incorrect.	Verify connection of external trip circuit at J1-16. Set external trip parameter to "OFF" if no connection made at J1-16.
Following ERR	Speed proportional gain set too low.	Following error tolerance band set too narrow. Increase Speed PROP Gain parameter value.
	Current limit set too low.	Increase Current Limit parameter value.
	ACCEL/DECEL time too short.	Increase ACCEL/DECEL parameter time
	Excessive load.	Verify proper sizing of control and motor.
	Following Error parameter set to ON by mistake.	Set Level 2 Protection block, Following Error parameter to OFF.
	Following Error window too small.	Increase Level 1 Output block, AT Speed Band parameter RPM.
INT Over-Temp	Motor Overloaded.	Correct motor loading. Verify proper sizing of control and motor.
	Ambient temperature too high.	Relocate control to cooler operating area. Add cooling fans or air conditioner to control cabinet.
Invalid Base ID	Control does not recognize HP and Voltage configuration.	Press "RESET" key on keypad. If fault remains, call Baldor.
Logic Supply FLT	Power supply malfunctioned.	Replace logic power supply.
Lost User Data	Battery backed memory failure.	Parameter data was erased. Disconnect power to control and apply power (cycle power). Enter all parameters. Cycle power. If problem persists, contact Baldor.
Memory Error	EEPROM memory fault occurred.	Press "RESET" key on keypad. If fault remains, call Baldor.
μP Reset	A processor error occurred or the 5VDC power was lost.	Press "RESET" key on keypad. If fault remains, call Baldor.
Low Line	The AC input line is below the rated input voltage limits.	Check AC input power. Correct if below minimum requirements.
High Line	The AC input line is above the rated input voltage limits.	Check AC input power. Correct if above minimum requirements.
Field Loss	Using permanent magnet DC motor.	Set control parameters for PERMANENT MAGNET in MOTOR DATA block, FIELD TYPE.
	Blown fuse in field power supply.	Check fuses and replace as needed.
	Improperly wired motor field.	Check motor field connections for correctness and continuity.

Table 4-4 Troubleshooting Continued

INDICATION	POSSIBLE CAUSE	CORRECTIVE ACTION
Motor has wrong response to Speed Command	Analog input common mode voltage may be excessive.	Connect control input source common to control common to minimize common mode voltage. Maximum common mode voltage at terminals J1-4 and J1-5 is ± 15 VDC referenced to chassis common.
	Speed is 4 times the commanded speed, with encoder feedback	Check if \bar{A} and \bar{B} are reversed.
Motor Will Not Start	Not enough starting torque.	Increase Current Limit setting.
	Motor overloaded.	Check for proper motor loading. Check couplings for binding. Verify proper sizing of control and motor.
	Motor field parameter incorrect.	Change to Shunt or PERM Magnet as required.
	Control not in local mode of operation.	Place control in local mode.
	MAX output speed parameter set to zero (0).	Change Level 2 Output Limits, MAX Output Speed parameter.
	Incorrect Command Select parameter.	Change Command Select parameter to match wiring at J1.
	Incorrect speed command.	Verify control is receiving proper command signal at J1.
Motor Will Not Reach Maximum Speed	Motor Field Volts or Field Amps parameters are not correct.	Change Level 2 Motor Data, Field Volts or Field Amps parameter(s).
	Max Output Speed set too low.	Adjust MAX Output Speed parameter value.
	Motor overloaded.	Check for mechanical overload. If unloaded motor shaft does not rotate freely, check motor bearings.
	Improper speed command.	Verify control is set to proper operating mode to receive speed command. Verify control is receiving proper command signal at input terminals. Check velocity loop gains.
	Speed potentiometer failure.	Replace potentiometer.
Motor Will Not Stop Rotation	MIN Output Speed parameter set too high.	Adjust MIN Output Speed parameter value.
	Improper speed command.	Verify control is receiving proper command signal at input terminals. Verify control is set to receive speed command.
	Speed potentiometer failure.	Replace potentiometer.
	Using Armature feedback and commanding 0 speed.	Motor stops when STOP key is pressed or control is disabled. Add TACH or Encoder feedback to improve zero speed performance.
Motor will not reverse	Reversing Contactor not installed.	Install reversing contactor as described in Section 2 of this manual.
	Dynamic Brake resistor and contactor not installed.	Install dynamic brake hardware as described in Section 2 of this manual.

Table 4-4 Troubleshooting Continued

INDICATION	POSSIBLE CAUSE	CORRECTIVE ACTION
No Display	Lack of input voltage.	Check input power for proper voltage. Verify fuses are good (or breaker is not tripped).
	Loose connections.	Check input power termination. Verify connection of operator keypad.
	Adjust display contrast.	See Adjust Display Contrast in Section 2 of this manual.
	Encoder +VDC and common wires may be reversed.	Check encoder connections and correct any mistakes.
New Base ID	Software parameters are not initialized on newly installed control board.	Press "RESET" key on keypad to clear the fault condition. Cycle power (turn power OFF then ON). Reset parameter values to factory settings. Access diagnostics and compare power base ID number to list in Table 4-5 to ensure a match. Re-enter the Parameter Block Values you recorded in the User Settings at the end of this manual. Autotune the control.
No EXB Installed	Incorrect operating mode programmed.	Change Operating Mode in the Level 1 Input block to one that does not require the expansion board.
	Need expansion board.	Install the correct expansion board for selected operating mode.
	Defective EXB.	Check connections of board to control or other group board. Check expansion board manual for correct connections. Call Baldor if problem remains.
Over Current FLT	Current Limit parameter set to fast for motor commutation.	Increase PK Current Limit parameter in the Level 2 Output Limits block, not to exceed drive rating.
	ACCEL/DECEL time too short.	Increase ACCEL/DEC parameters in the Level 1 ACCEL/DECEL Rate block.
	Electrical noise from external DC coils.	Install reverse biased diodes across all external DC relay coils as shown in the Opto Output circuit examples of this manual. See Electrical Noise Considerations in Section 4 of this manual.
	Electrical noise from external AC coils.	Install RC snubbers on all external AC coils. See Electrical Noise Considerations in Section 4 of this manual.
	Excessive load.	Reduce the motor load. Verify proper sizing of control and motor.
	Current Rate Limit parameter set too fast for motor commutation.	Increase the Level 2 Output Limits block, CUR Rate Limit parameter time value.
Overload	Excessive Current.	Check PK Current Limit parameter in the Level 2 Output Limits block. Change Overload parameter In the Level 2 Protection block from Trip to Foldback. Check motor for overloading. Increase ACCEL/DECEL times. Reduce motor load. Verify proper sizing of control and motor.
	Encoder coupling slipping, broken or misaligned.	Correct or replace encoder to motor coupling.
	Encoder bearing failure.	Replace and align encoder.
Over Speed	Motor exceeded 110% of MAX Speed parameter value.	Check the Level 2 Output Limits block, Max Output Speed parameter. Increase the Level 1 DC Control block, Speed PROP Gain parameter.
Torque Prove FLT	Insufficient current to motor.	Check continuity from control to motor windings and verify motor connections and brushes. This check is only performed when motor is started and when control is first enabled.
Unknown Fault	Fault occurred but cleared before its source could be identified.	Check AC line for high frequency noise. Check input switch connections and switching noise.
User Fault Text	Fault detected by custom software.	Refer to custom software fault list.

Table 4-5 Power Base ID - Series 19H

230VAC Control Catalog Numbers	Power Base ID	460VAC Control Catalog Numbers	Power Base ID
		BC19H410-CO	33C
BC19H205-CO	2F2	BC19H420-CO	344
BC19H210-CO	2FA	BC19H430-CO	34C
BC19H215-CO	302	BC19H440-CO	354
BC19H220-CO	30A	BC19H450-CO	35C
BC19H225-CO	312	BC19H475-CO	364
BC19H240-CO	31A	BC19H4100-CO	36C
BC19H250-CO	322	BC19H4125-CO	374
BC19H260-CO	32A	BC19H4150-CO	37C
BC19H275-CO	332	BC19H4200-CO	3A4
		BC19H4250-CO	384
		BC19H4300-CO	38C

Note: The Power Base ID number of a control is displayed in a Diagnostic Information screen as a hexadecimal value.

Electrical Noise Considerations All electronic devices including the Series 19H Control are vulnerable to significant electronic interference signals (commonly called “Electrical Noise”). At the lowest level, noise can cause intermittent operating errors or faults. From a circuit standpoint, 5 or 10 millivolts of noise may cause detrimental operation. For example, analog speed and torque inputs are often scaled at 5 to 10 VDC maximum with a typical resolution of one part in 1,000. Thus noise of only 5 mV represents a substantial error.

At the extreme level, significant noise can cause damage to the drive. Therefore, it is advisable to prevent noise generation and to follow wiring practices that prevent noise generated by other devices from reaching sensitive circuits. In a control, such circuits include inputs for speed, torque, control logic, and speed and position feedback, plus outputs to some indicators and computers.

Causes and Cures

Unwanted electrical noise can be produced by many sources. Depending upon the source, various methods can be used to reduce the effects of this noise and to reduce the coupling to sensitive circuits. All methods are less costly when designed into a system initially than if added after installation.

Figure 4-1 shows an oscilloscope trace of noise induced (as the coil circuit is opened) in a 1-ft. wire located next to a lead for a Size 2 contactor coil. Scope input impedance is 10K Ω for all scope traces. Maximum peak voltage is over 40V. Unless well filtered this is often enough noise to ruin the output of a productive machine.

Figure 4-1 Electrical Noise Display

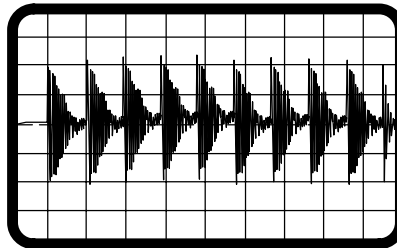

Relay and Contactor Coils Among the most common sources of noise are the ever-present coils of contactors and relays. When these highly inductive coil circuits are opened, transient conditions often generate spikes of several hundred volts in the control circuit. These spikes can induce several volts of noise in an adjacent wire that runs parallel to a control-circuit wire.

To suppress noise in these AC coils, add an R-C snubber across each relay and contactor coil. A snubber consisting of a 33K Ω resistor in series with a 0.47 μ F capacitor usually works well. The snubber reduces the rate of rise and peak voltage in the coil when current flow is interrupted. This eliminates arcing and reduces the noise voltage induced in adjacent wires. In our example, the noise was reduced from over 40 V_{peak} to about 16 V_{peak} as shown in Figure 4-2.

Figure 4-2 R-C Snubber Circuit

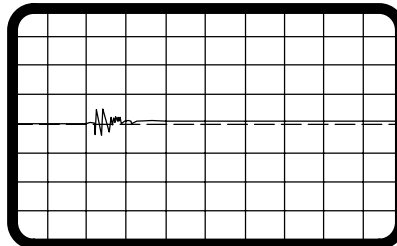

Electrical Noise Considerations Continued

Combining an R-C snubber and twisted-pair shielded cable keeps the voltage in a circuit to less than 2 V for a fraction of a millisecond. The waveform shown in Figure 4-3 in addition to the snubber across the coil, the adjacent wire is grounded in a twisted-pair, shielded cable. Note that the vertical scale is 1 V/div., rather than the 20 V/div. in figures 4-1 and 4-2. This shows that snubbers and twisted-pair shielded wire should be used for sensitive circuits located adjacent to coil wires.

Figure 4-3 R-C Snubber Circuit & twisted-pair

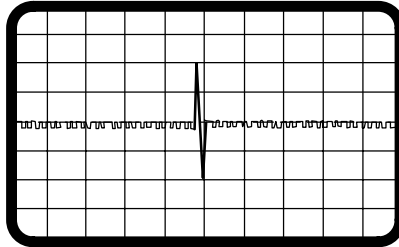

A reverse biased diode across a DC coil achieves the same result as adding an R-C snubber across an AC coil, Figure 4-4.

Figure 4-4 AC & DC Coil Noise Suppression

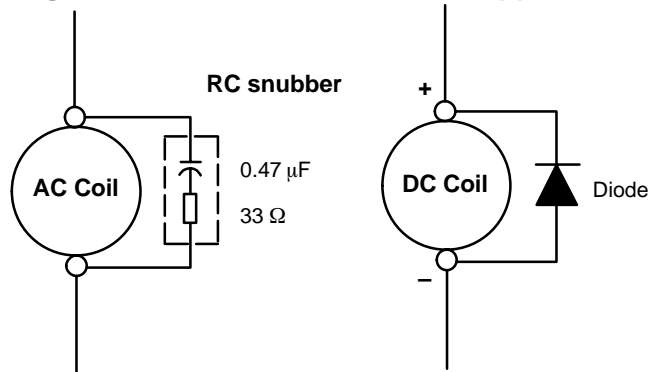

Electrical Noise Considerations Continued

Wires between Controls and Motors

Output leads from a typical 460 VAC drive controller contain rapid voltage rises created by power semiconductors switching 650V in less than a microsecond, 1,000 to 10,000 times a second. These noise signals can couple into sensitive drive circuits as shown in Figure 4-5. For this waveform, a transient induced in 1 ft. of wire adjacent to motor lead of a 10 hp, 460 VAC drive. Scope is set at 5 V/div. and 2 μ sec/div.

Figure 4-5 10HP, 460VAC Drive

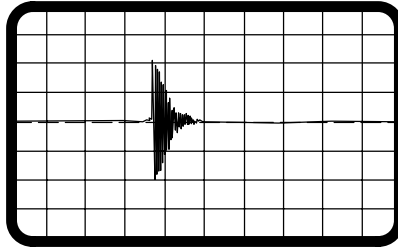

If the shielded pair cable is used, the coupling is reduced by nearly 90%, Figure 4-6.

Figure 4-6 10HP, 460VAC Drive, Shielded

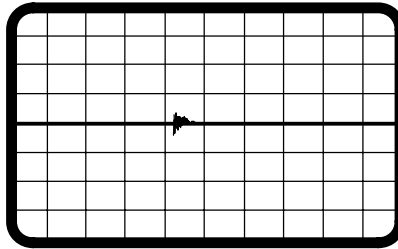

The motor leads of DC motors contain similar voltage transients. The switching rate is about 360 times a second. These noise transients can produce about 2V of noise induced in a wire adjacent to the motor lead. A 30HP, 500VDC Drive, as shown in Figure 4-7. Scope is set at 1 V/div. and 5 μ sec/div.

Figure 4-7 30HP, 500VDC Drive

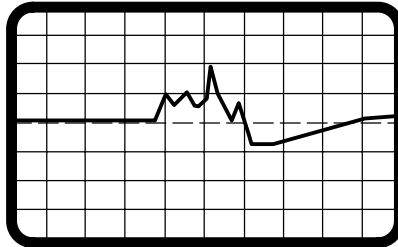

Again, Replacing a single wire with a shielded pair cable reduces the induced noise to less than 0.3 V, Figure 4-8.

Figure 4-8 30HP, 500VDC Drive, Shielded

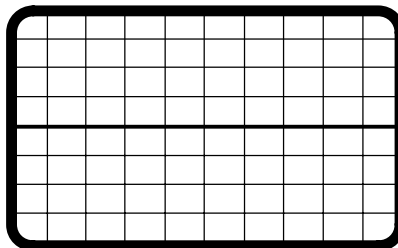

Electrical Noise Considerations Continued

Even input AC power lines contain noise and can induce noise in adjacent wires. This is especially severe with SCR controlled DC drives, current-source and six-step inverters. Figure 4-9 shows a transient induced in 1-ft. wire adjacent to AC input power wire to 20 hp, DC drive. Scope is set at 500 mV/div. and 2 μ sec/div.

Figure 4-9 30HP, 500VDC Drive, Shielded

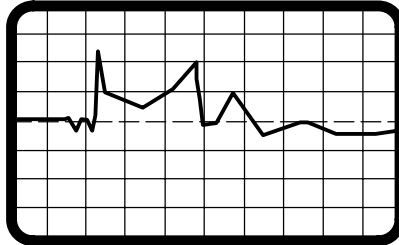

To prevent induced transient noise in signal wires, all motor leads and AC power lines should be contained in rigid metal conduit, or flexible conduit. Do not place line conductors and load conductors in same conduit. Use separate conduit for 3 phase input wires and motor leads. The conduit should be grounded to form a shield to contain the electrical noise within the conduit path. Signal wires - even ones in shielded cable should never be placed in the conduit with motor power wires.

If flexible conduit is required, the wires should be shielded twisted-pair. Although this practice gives better protection than unshielded wires, it lacks the protection offered by rigid metal conduit.

Special Drive Situations For severe noise situations, it may be necessary to reduce transient voltages in the wires to the motor by adding load reactors. Load reactors are installed between the control and motor. These are often required where a motor housing lacks the necessary shielding (typically linear motors mounted directly to machine frames) or where the power wires to motors are contained in flexible cables.

Reactors are typically 3% reactance and are designed for the frequencies encountered in PWM drives. For maximum benefit, the reactors should be mounted in the drive enclosure with short leads between the control and the reactors. Baldor offers a complete line of line and load reactors that will reduce ripple current and improve motor life.

Drive Power Lines

The same type of reactor as installed on the load side of the control can also suppress transients on incoming power lines. Connected on the line side of the drive, the reactor protects the adjustable-speed drive from some transients generated by other equipment and suppresses some of the transients produced by the drive itself.

Radio Transmitters

Not a common cause of noise, radio frequency transmitters, such as commercial broadcast stations, fixed short-wave stations, and mobile communications equipment (including walkie talkies) create electrical noise. The probability of this noise affecting an adjustable-speed drive increases with the use of open control enclosures, open wiring, and poor grounding.

Electrical Noise Considerations Continued

Control Enclosures

Motor controls mounted in a grounded enclosure should also be connected to earth ground with a separate conductor to ensure best ground connection. Often grounding the control to the grounded metallic enclosure is not sufficient. Usually painted surfaces and seals prevent solid metallic contact between the control and the panel enclosure. Likewise, conduit should never be used as a ground conductor for motor power wires or signal conductors.

Special Motor Considerations

Motor frames are also on the required grounding list. As with control enclosures, motors should be grounded directly to the control and plant ground with as short a ground wire as possible. Here's why. Capacitive coupling within the motor windings produces transient voltages between the motor frame and ground. The severity of these voltages increases with the length of the ground wire. Installations with the motor and control mounted on a common frame, and with heavy ground wires less than 10 ft. long, rarely have a problem caused by these motor-generated transient voltages.

Another cure may be needed when the motor frame transient voltages are capacitively coupled to feedback devices mounted on the motor shaft. Especially with optical encoders, these transients create noise on the signal leads and disrupt drive operation.

To prevent this problem, add electrical isolation between the motor and the feedback device to stop the current flow and the resulting transients. The most simple isolation method, shown in Figure 4-10, has two parts: 1) A plate of electrical insulating material placed between the motor mounting surface and the feedback device. 2) An insulating coupling between motor shaft and the shaft of the feedback device.

Figure 4-10 Isolated Mounting Method

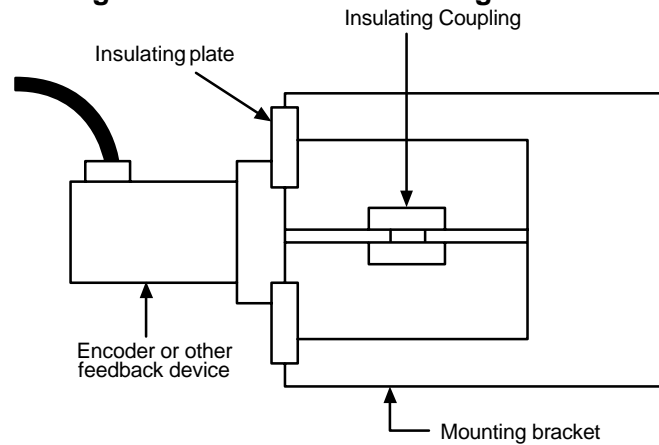

Wiring Practices

The type of wire used and how it is installed for specific applications makes the difference between obtaining reliable operation and creating additional problems.

Power Wiring

Conductors carrying power to anything (motor, heater, brake coil, or lighting units, for example) should be contained in conductive conduit that is grounded at both ends.

These power wires must be routed in conduit separately from signal and control wiring.

Control–logic Conductors

Typically, operator's controls (push buttons and switches), relay contacts, limit switches, PLC I/O's, operator displays, and relay and contactor coils operate at 115VAC or 24VDC. Although these devices usually operate at low current levels, they contain switching noise caused by contact open/closure and solid–state switch operations. Therefore, these wires should be routed away from sensitive signal wires and contained within conduits or bundled away from open power and signal wires.

DC Tachometer Circuits

Among the most sensitive circuits is the DC Tachometer. Reliability of a DC tachometer circuit is often improved by the following noise reduction techniques:

- Connect a 0.1 μF capacitor across the tachometer terminals to suppress AC noise.
- Use twisted-pair shielded wires with the shield grounded at the control end only. You should avoid grounding the shield to the tachometer case or conduit.
- Follow the practices for analog signal wiring.

Analog Signal Wires

Analog signals generally originate from speed and torque controls, plus DC tachometers and process controllers. Reliability is often improved by the following noise reduction techniques:

- Use twisted-pair shielded wires with the shield grounded at the drive end only.
- Route analog signal wires away from power or control wires (all other wiring types).
- Cross power and control wires at right angles (90°) to minimize inductive noise coupling.

Encoder Circuits

Adjustable speed drives are especially sensitive to high frequency noise on encoder signal lines. Because these input signals cannot be heavily filtered special care must be taken to avoid transient noise from entering these signal lines. Drive reliability can be greatly improved by using the following noise reduction techniques:

- Use line driver output encoders to reduce the encoder output impedance.
- Select line driver inputs on the adjustable speed drive.
- Install twisted-pair shielded wire for power to the encoder and having each output with its own return. (Avoid common conductors with multiple outputs or with an output and the power source.)
- Never connect the encoder ground to the power ground terminal of the control.
- Run all encoder wires independently from all other power wires.

Serial Communication Conductors

Standard serial communication cables are usually made with a shield that is connected to the connector shell at both ends. This usually grounds the data source to the grounded drive chassis. If the data source is floating, such a connection offers good data transmission. However, if the data source is grounded, adding a heavy ground wire (#14 or larger) in parallel with the communication cable between the source and the drive chassis usually reduces noise problems.

Optical Isolation

Isolating electrical circuits with some form of light transmission reduces the electrical noise that is transmitted from one part of a circuit to another. That is, an electrical signal is converted to a light signal that is transmitted to a light receiver. This converts the light back to an electrical signal that has less noise than the input. Two methods are commonly used; optical couplers and fiber optics.

Optical Couplers

Optical couplers, often referred to as opto couplers use a light transmitter and light receiver in the same unit to transmit data while electrically isolating two circuits. This isolation rejects some noise. The magnitude of noise rejection is usually specified by the "common mode rejection, dv/dt rating". Typically, low cost opto couplers have a common mode rejection of 100 to 500 V/ μ sec, which is adequate for most control logic signals. High performance opto couplers with common mode ratings up to 5,000 V/ μ sec are installed for the most severe noise environments.

Fiber Optics

Special plastic fiber strands transmit light over long as well as short distances. Because the fibers are immune to electromagnetic energy, the use of fiber optic bundles eliminate the problem of coupling noise into such circuits. These noise-free fiber optic cables can be run with power or motor conductors because noise cannot be inductively or capacitively coupled into the fiber optic stands.

Plant Ground

Connecting electrical equipment to a good ground is essential for safety and reliable operation. In many cases, what is perceived as a ground isn't. Result: equipment malfunctions or electrical shock hazard exists.

It may be necessary to retain the services of an electrical consultant, who is also a licensed professional engineer experienced in grounding practices to make the necessary measurements to establish if the plant ground is really grounded.

Section 5 Specifications and Product Data

Specifications:

Enclosure:	Open Type (Chassis Mount)
Horsepower	3-75 HP @ 230VAC 5-300 HP @ 460VAC
Input Frequency	50/60 HZ \pm 5%
Output Voltage	0 to (1.30 x Input VAC)VDC
Output Current	See Ratings Table 5-1
Service Factor	1.0
Duty	Continuous
Overload Capacity	See Ratings Table 5-1

Operating Conditions:

Voltage Range:	230 VAC Models 460 VAC Models ¹	180-264 VAC 3 \emptyset 60 Hz / 180-230 VAC 3 \emptyset 50 Hz 340-528 VAC 3 \emptyset 60 Hz / 340-460 VAC 3 \emptyset 50 Hz
Input Frequency Variation:		\pm 5%, 8.0Hz/Second Maximum Slew Rate
Input Line Impedance:		5% Maximum
Ambient Operating Temperature:		0 to +40 °C Derate Output 2% per °C over 40 °C to 55 °C Max
Rated Storage Temperature:		- 30 °C to +65 °C
Humidity:		10 to 90% RH Non-Condensing
Altitude:		Sea level to 3300 Feet (1000 Meters) Derate 2% per 1000 Feet (303 Meters) above 3300 Feet
Shock:		1G
Vibration:		0.5G at 10Hz to 60Hz

¹ 460VAC control requires 230VAC 1 \emptyset for cooling fans on some B and C size controls. See Table 5-1.

Keypad Display:

Display	Backlit LCD Alphanumeric 2 Lines x 16 Characters
Keys	12 key membrane with tactile response
Functions	Output status monitoring Digital speed control Parameter setting and display Diagnostic and Fault log display Motor run and jog Local/Remote toggle
LED Indicators	Forward run command Reverse run command Stop command Jog active
Remote Mount	100 feet (30.3m) max from control

Control Specifications:

Control Method	Three phase, full wave, uni-directional DC control with 6 total pulses per cycle and 6 controlled pulses per cycle. NEMA Type C.
Speed Regulation Feedback Type:	
Armature	1% of base speed
Encoder	0.1% of set speed
Tachometer (optional)	1% of set speed
Resolver (optional)	0.1% of set speed
Current (Rate Limit) - Time to peak current	0.008 Seconds - 1.0 Seconds
Accel / Decel Time	0 - 3600 Seconds for 2 assignable presets plus JOG
S-Curve Time	0 - 100%
JOG Speed	0 - Maximum speed
Minimum Output Speed	0 - Maximum speed
Maximum Output Speed	0 - Maximum speed
Auto Restart	Manual or Automatic
IR Compensation Gain	Available for Armature Feedback
Velocity Loop Bandwidth	Adjustable to 20Hz
Current Loop Bandwidth	Adjustable to 70Hz
Selectable Operating Modes	Keypad Standard Run 3 Wire 2 Wire Control with 15 Presets Bipolar Speed/Torque Process Mode Serial

Field Power Supply:

Type	Voltage Limited, Current Regulated Full Wave Single Phase
Voltage	0-85% of AC Line Input (in DC Volts)
Current	0.1 - 15 Amperes maximum standard 0.3 - 40 Amperes maximum optional Off for Permanent Magnet Motors
Field Economy Level	Off, 25 - 100%

Differential Analog Input:

Common Mode Rejection	40 db
Full Scale Range	$\pm 5\text{VDC}$, $\pm 10\text{VDC}$, 4-20 mA
Auto-selectable Resolutions	12 bits + sign below 1VDC command 9 bits + sign above 1VDC command
Update rate	2.7 msec with a 60Hz line

Other Analog Input:

Full Scale Range	$\pm 10\text{ VDC}$
Resolution	9 bits + sign
Update Rate	2.7 msec with a 60Hz line

Analog Outputs:

Analog Outputs	2 Assignable
Full Scale Range	0 - 5 VDC
Source Current	1 mA maximum
Resolution	8 bits
Update Rate	2.7 msec with a 60Hz line

Digital Inputs:

Opto-isolated Logic Inputs	9 Assignable
Rated Voltage	10 - 30 VDC (closed contacts standard)
Input Impedance	6.8 K Ohms
Leakage Current	10 μ A maximum
Update Rate	16.6 msec

Digital Outputs:

Opto-isolated Logic Outputs	4 Assignable
ON Current Sink	60 mA Max
ON Voltage Drop	2 VDC Max
Update Rate	16.6 msec
Maximum Voltage	30 VDC

Diagnostic Indications:

Current Sense Fault	Ready	Following Error
Instantaneous Over Current	Parameter Loss	Encoder Loss
Microprocessor Failure	Overload	Tach Loss
Over temperature (Control)	Torque Proving	Field Loss
Over speed	Expansion Board Fault	Resolver Loss
ARM Volts Sense Fault	External Trip (Motor Over Temp)	Invalid Power Base ID
Field Sense Fault	High Line Fault	Phase Loss
Check Tach Jumpers	Low Line Fault	

Note: All specifications are subject to change without notice.

Table 5-1 Ratings

Input VAC	Catalog Number	Max. Output					Size	Cooling Blower Voltage	Blower Power Requirement
		Volts	HP	KW	RMS Amps	Peak Amps			
230	BC19H205-CO	240	5	3.7	20	40	A	-	-
230	BC19H210-CO	240	10	7.5	40	60	A	-	-
230	BC19H215-CO	240	15	11.2	60	120	A	-	-
230	BC19H220-CO	240	20	14.9	75	150	B	-	-
230	BC19H225-CO	240	25	18.6	100	200	B	230 VAC	1x24 Watt
230	BC19H240-CO	240	40	29.8	140	280	C	230 VAC	2x24 Watt
230	BC19H250-CO	240	50	37.3	180	360	C	230 VAC	2x24 Watt
230	BC19H260-CO	240	60	44.8	210	420	C	230 VAC	2x24 Watt
230	BC19H275-CO	240	75	56	270	540	C	230/460 VAC	1x.95A/.48A
460	BC19H410-CO	500	10	7.5	20	40	A	-	-
460	BC19H420-CO	500	20	14.9	40	80	A	-	-
460	BC19H430-CO	500	30	22.4	60	120	A	-	-
460	BC19H440-CO	500	40	29.8	75	150	B	-	-
460	BC19H450-CO	500	50	37.3	100	200	B	☐ 115VAC	1x24 Watt
460	BC19H475-CO	500	75	56	140	280	C	☐ 115VAC	2x24 Watt
460	BC19H4100-CO	500	100	74.6	180	360	C	☐ 115VAC	2x24 Watt
460	BC19H4125-CO	500	125	93	210	420	C	230/460VAC	1x.95A/.48A
460	BC19H4150-CO	500	150	112	270	540	C	230/460VAC	1x.95A/.48A
460	BC19H4200-CO	500	200	149	350	875	D	230/460VAC	1x.95A/.48A
460	BC19H4250-CO	500	250	187	420	840	D	230/460VAC	1x.95A/.48A
460	BC19H4300-CO	500	300	224	500	1000	D	230/460VAC	1x.95A/.48A

☐ Controls built before 2nd quarter 1996 have 230VAC fans.

Peak Amps are Rated for 3 Seconds Maximum.

150% of motor amps – 60 seconds

200% of motor amps – 8 seconds

Note: All specifications are subject to change without notice.

Table 5-2 Tightening Torque Specifications

Catalog Number	L1, L2 & L3		A1		A2		Field Power		J1		Ground Lug		Thermal Terminals		Control Ground	
	lb-in	Nm	lb-in	Nm	lb-in	Nm	lb-in	Nm	lb-in	Nm	lb-in	Nm	lb-in	Nm	lb-in	Nm
BC19H205-CO	160	18.1	30	3.4	30	3.4	12	1.4	7	0.8	50	5.6	5	.56	5	.56
BC19H210-CO	160	18.1	30	3.4	30	3.4	12	1.4	7	0.8	50	5.6	5	.56	5	.56
BC19H215-CO	160	18.1	30	3.4	30	3.4	12	1.4	7	0.8	50	5.6	5	.56	5	.56
BC19H220-CO	275	31	200	22.6	275	31	5	.56	7	0.8	200	22.6	5	.56	5	.56
BC19H225-CO	275	31	200	22.6	275	31	5	.56	7	0.8	200	22.6	5	.56	5	.56
BC19H240-CO	275	31	200	22.6	275	31	5	.56	7	0.8	200	22.6	5	.56	5	.56
BC19H250-CO	275	31	200	22.6	275	31	5	.56	7	0.8	200	22.6	5	.56	5	.56
BC19H260-CO	275	31	200	22.6	275	31	5	.56	7	0.8	200	22.6	5	.56	5	.56
BC19H275-CO	275	31	200	22.6	275	31	5	.56	7	0.8	200	22.6	5	.56	5	.56
BC19H410-CO	160	18.1	30	3.4	30	3.5	12	1.4	7	0.8	50	5.6	5	.56	5	.56
BC19H420-CO	160	18.1	30	3.4	30	3.5	12	1.4	7	0.8	50	5.6	5	.56	5	.56
BC19H430-CO	160	18.1	30	3.4	30	3.5	12	1.4	7	0.8	50	5.6	5	.56	5	.56
BC19H440-CO	275	31	200	22.6	275	31	5	.56	7	0.8	200	22.6	5	.56	5	.56
BC19H450-CO	275	31	200	22.6	275	31	5	.56	7	0.8	200	22.6	5	.56	5	.56
BC19H475-CO	275	31	200	22.6	275	31	5	.56	7	0.8	200	22.6	5	.56	5	.56
BC19H4100-CO	275	31	200	22.6	275	31	5	.56	7	0.8	200	22.6	5	.56	5	.56
BC19H4125-CO	275	31	200	22.6	275	31	5	.56	7	0.8	200	22.6	5	.56	5	.56
BC19H4150-CO	275	31	200	22.6	275	31	5	.56	7	0.8	200	22.6	5	.56	5	.56
BC19H4200-CO	375	42.4	375	42.4	375	42.4	5	.56	7	0.8	200	22.6	5	.56	5	.56
BC19H4250-CO	375	42.4	375	42.4	375	42.4	5	.56	7	0.8	200	22.6	5	.56	5	.56
BC19H4300-CO	375	42.4	375	42.4	375	42.4	5	.56	7	0.8	200	22.6	5	.56	5	.56

Inter-connect Diagram

Size A – D Controls

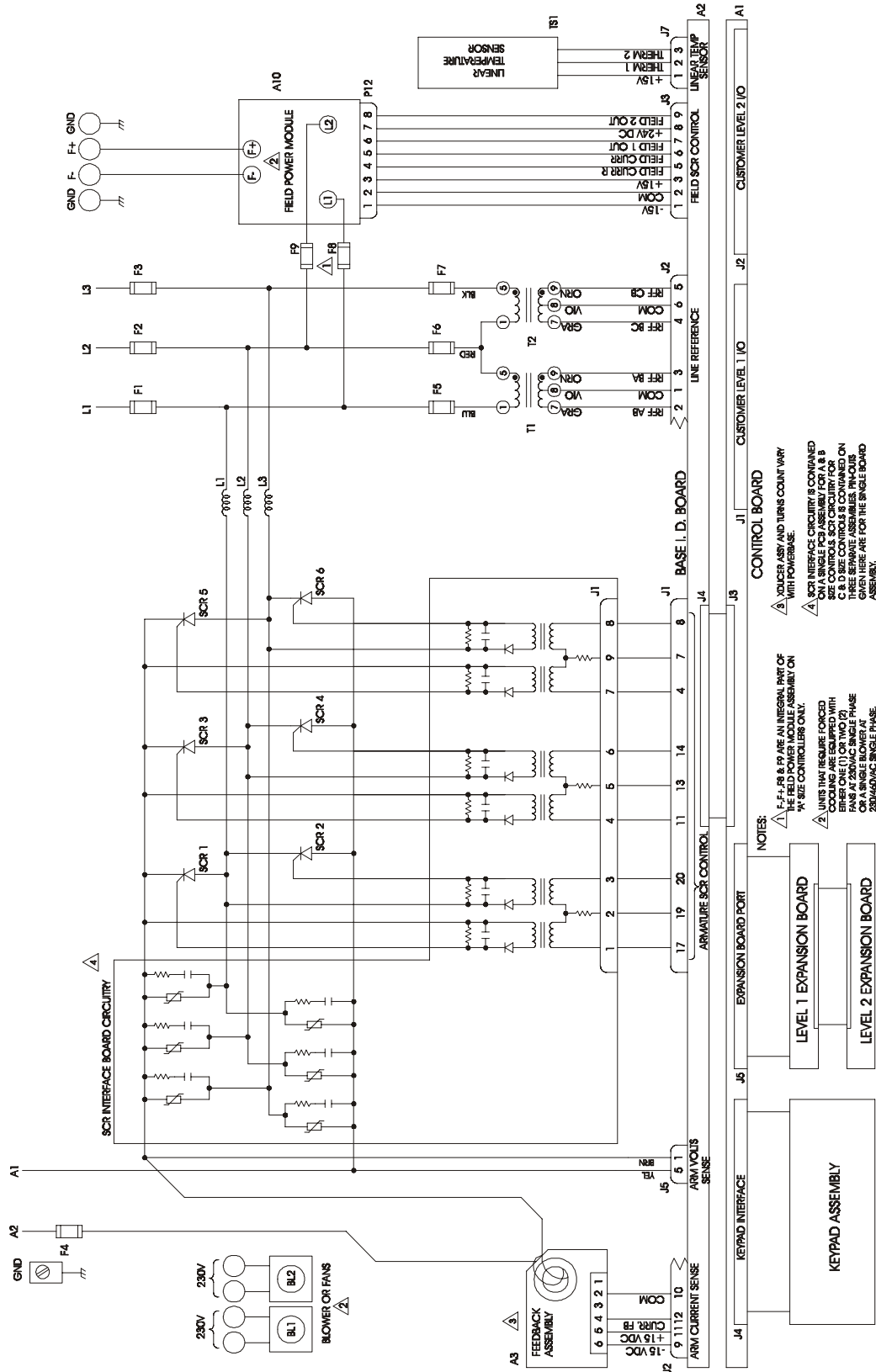

Dimensions

Size A Control

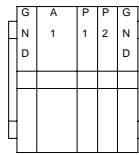
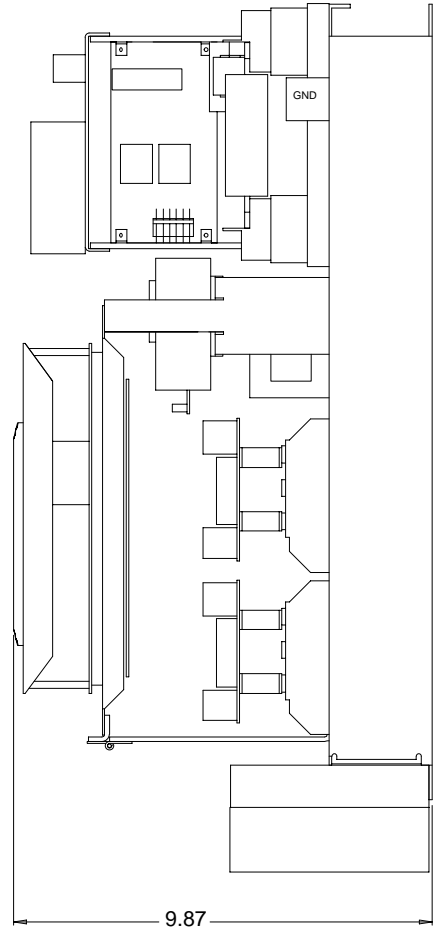
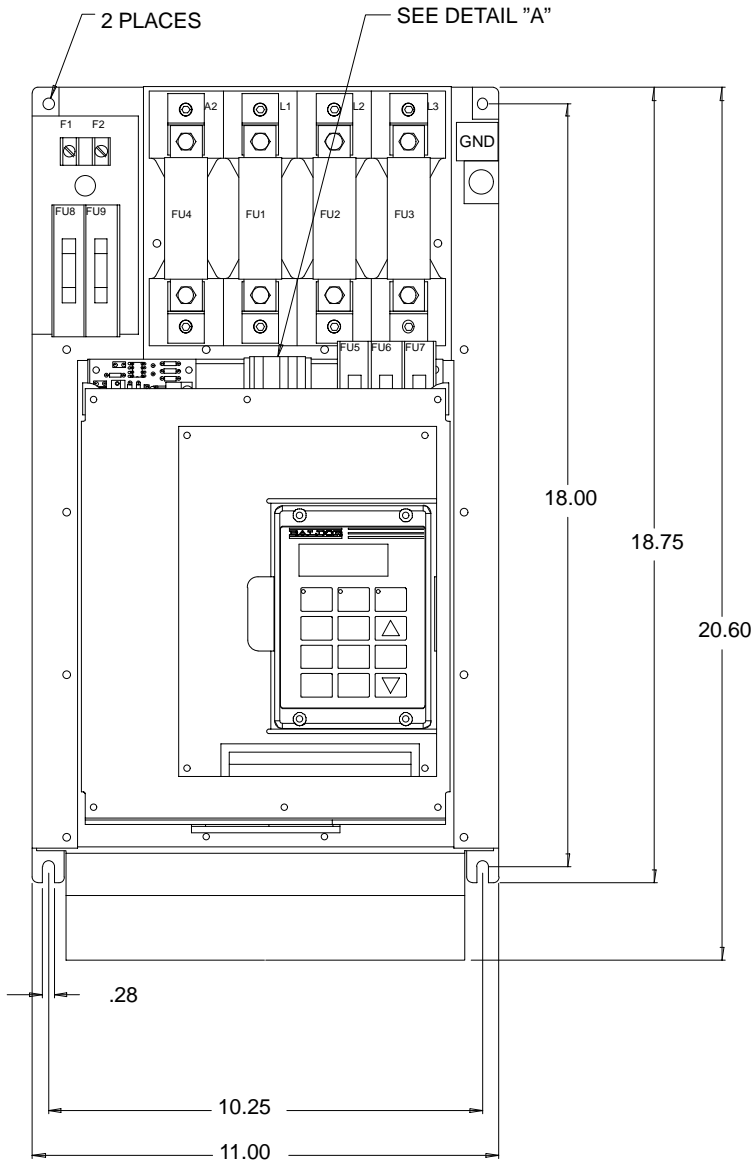

DETAIL "A"

Dimensions Continued

Size B Control

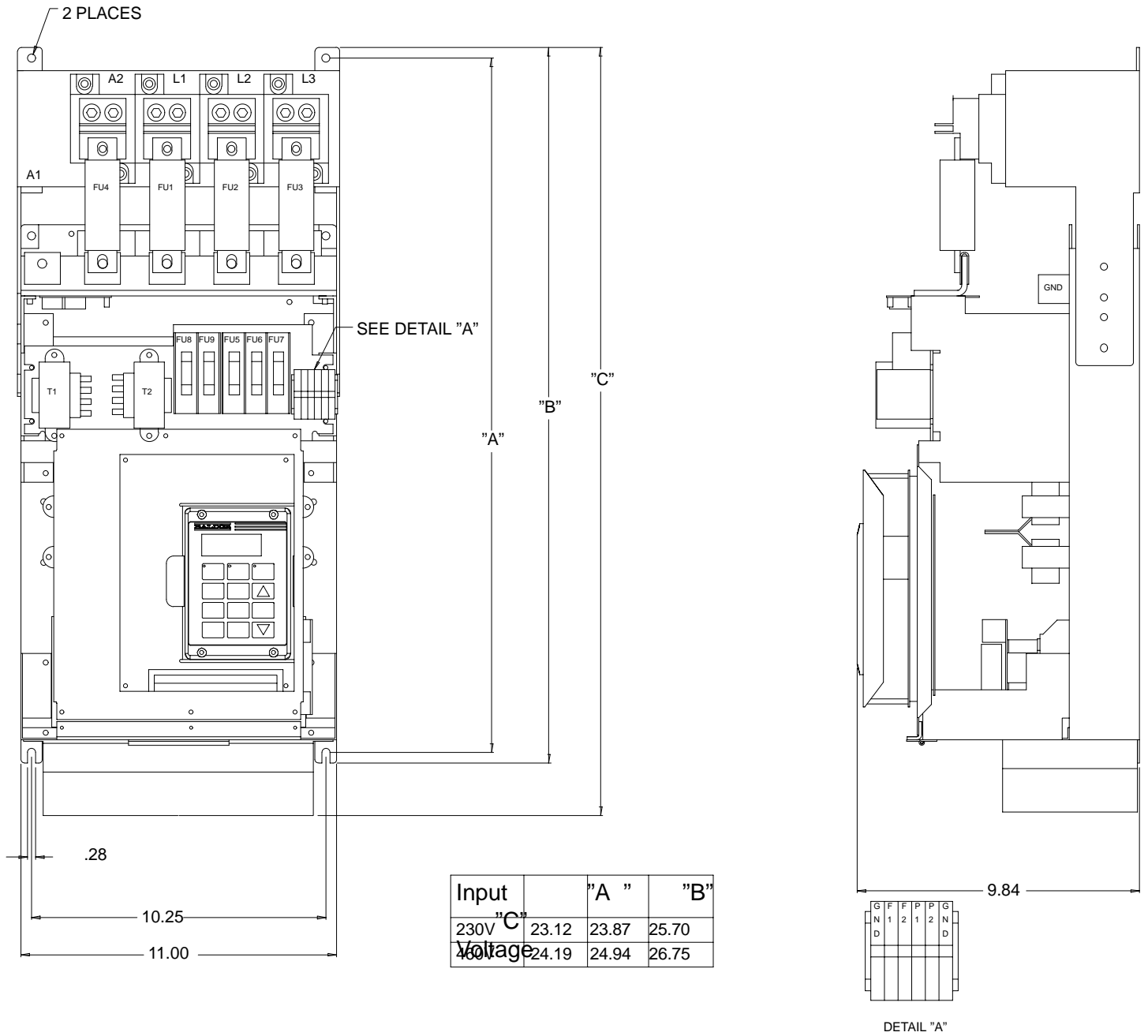

Dimensions Continued

Size C Control

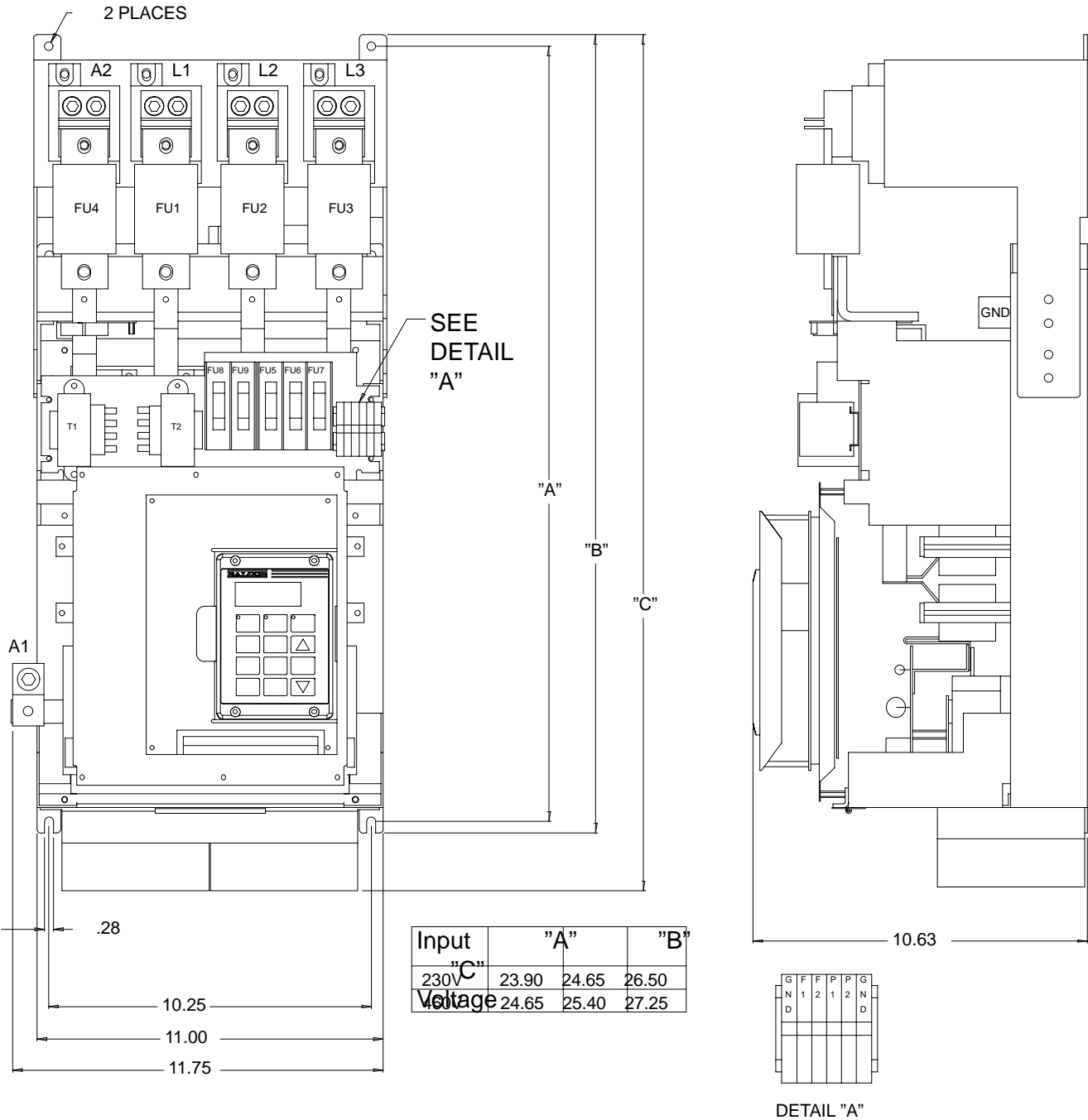

Dimensions Continued

Size D Control

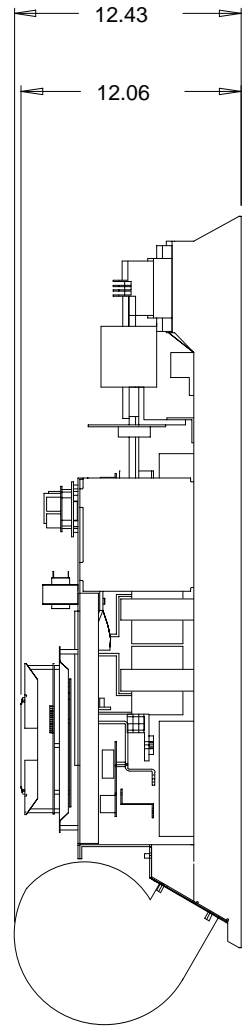
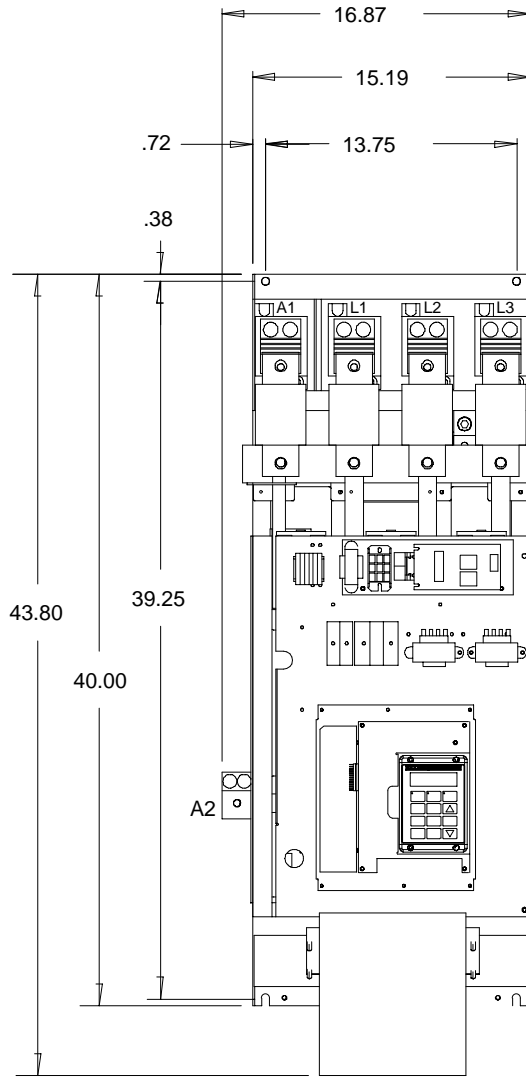

Appendix A

Field Supply Module

The standard field supply modules provide up to 85% of the incoming AC voltage as its maximum DC output voltage. Standard output current is 15 amps mounted to the control chassis with an optional separately mounted 40 amp maximum supply available from Baldor Electric.

It is possible to run motors with fields above 85% of the incoming AC voltage with the Series 19H control. Doing so requires a voltage step-up transformer to be added between the field supply module's LI – L2 connection. Note that this connection is phase sensitive with LI and L2. Maximum AC input voltage to the field supply module should be limited to 528 VAC on 60 Hz.

Required step up transformer is calculated:

$$\text{Minimum AC Input Volts} = \frac{\text{Required Maximum Motor Field Voltage}}{0.85}$$

Example:

Motor field volts required is 300 VDC, AC input is 230 VAC

$$\frac{\text{Required Maximum Motor Field Voltage}}{0.85} = \frac{300}{0.85} = 366\text{VAC Minimum AC Input}$$

Minimum step-up ratio for the transformer is calculated:

$$\frac{\text{Calculated Minimum AC Input Volts}}{\text{AC Line Input Volts}}$$

Transformer KVA is calculated by:

Transformer KVA = Max Field Volts x Max Field Amps

In the case of the voltage step-up transformer, the FIELD RATED VOLTS parameter should be calculated by:

$$\text{Field Rated Volts} = \text{Rated Field Volts} \times \frac{\text{Input Volts}}{\text{Output Volts}}$$

Example from above:

$$\text{Field Rated Volts} = 300\text{VDC} \times \left(\frac{230}{366}\right) = 188\text{VDC}$$

The standard field connection is shown in Figure A-1.

Figure A-1 Standard Field Connection

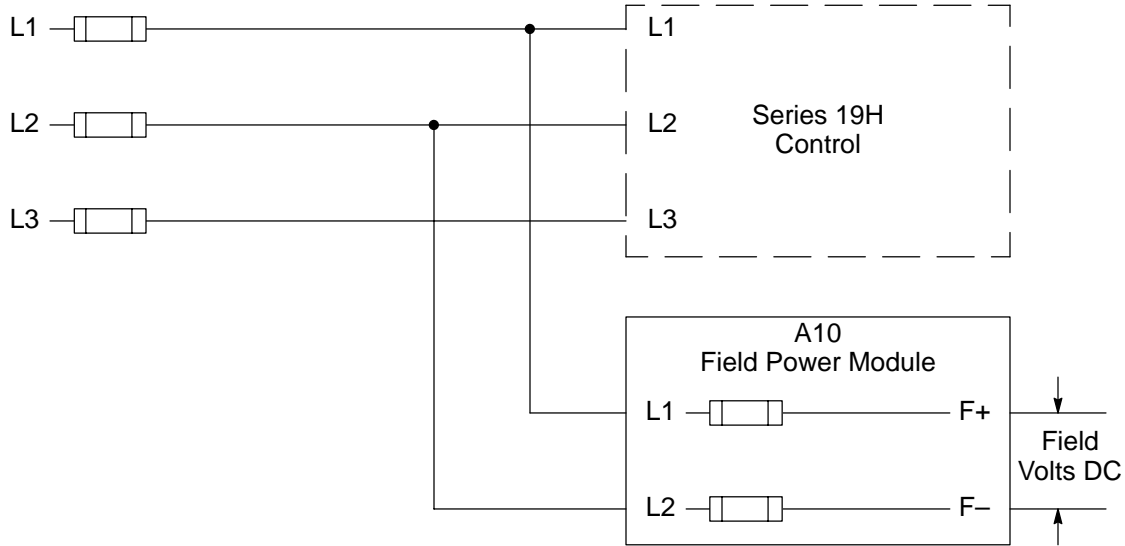

When using a transformer to boost the AC input to the field supply module to get a field voltage more than 85% of the AC line will be connected as shown in Figure A-2.

Figure A-2 Field Transformer Connection (to increase field output voltage)

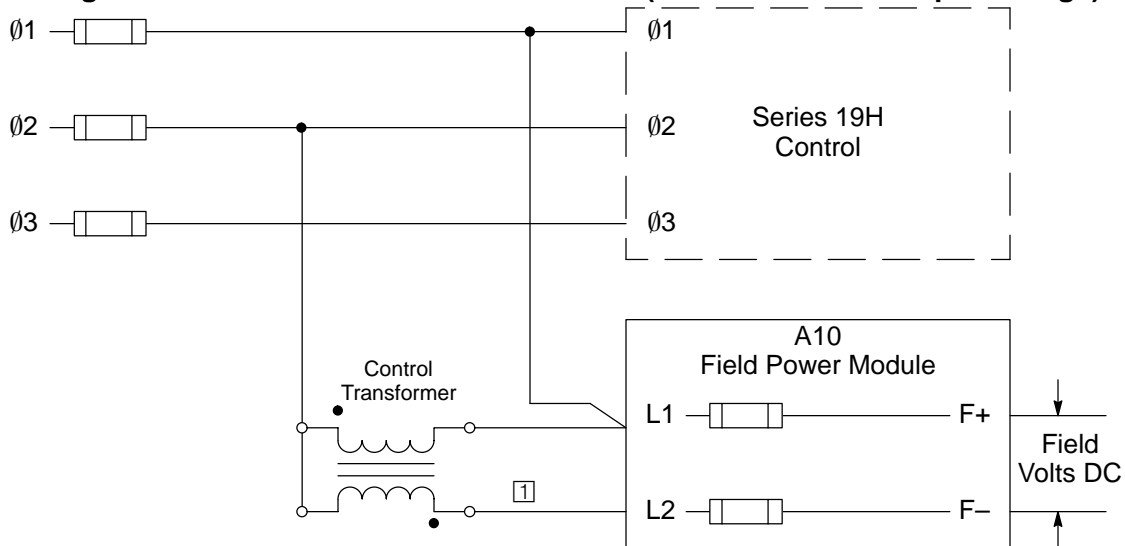

① Note that the wire that connects Ø2 with L2 of the Field Power Module is removed and the control transformer is connected.

1. Output field voltage is adjusted as specified for the application.

2. Maximum Motor Field Voltage = $0.85 \times V_{L1-L2}$

3. $V_{L1-L2} = V_{Ø1-Ø2} + N \times V_{Ø1-Ø2}$

Where N=Control transformer voltage ratio (Secondary/Primary)

4. Minimum control transformer VA rating = (Maximum Field Amps DC) x $NV_{Ø1-Ø2}$

Appendix B

Parameter Values

Parameter Block Values Level 1

Level 1 Blocks					
Block Title	Parameter	P#	Adjustable Range	Factory Setting	User Setting
PRESET SPEEDS	PRESET SPEED #1	1001	0-MAX Speed	0 RPM	
	PRESET SPEED #2	1002	0-MAX Speed	0 RPM	
	PRESET SPEED #3	1003	0-MAX Speed	0 RPM	
	PRESET SPEED #4	1004	0-MAX Speed	0 RPM	
	PRESET SPEED #5	1005	0-MAX Speed	0 RPM	
	PRESET SPEED #6	1006	0-MAX Speed	0 RPM	
	PRESET SPEED #7	1007	0-MAX Speed	0 RPM	
	PRESET SPEED #8	1008	0-MAX Speed	0 RPM	
	PRESET SPEED #9	1009	0-MAX Speed	0 RPM	
	PRESET SPEED #10	1010	0-MAX Speed	0 RPM	
	PRESET SPEED #11	1011	0-MAX Speed	0 RPM	
	PRESET SPEED #12	1012	0-MAX Speed	0 RPM	
	PRESET SPEED #13	1013	0-MAX Speed	0 RPM	
	PRESET SPEED #14	1014	0-MAX Speed	0 RPM	
	PRESET SPEED #15	1015	0-MAX Speed	0 RPM	
ACCEL/DECEL RATE	ACCEL TIME #1	1101	0 to 3600 Seconds	3.0 SEC	
	DECEL TIME #1	1102	0 to 3600 Seconds	3.0 SEC	
	S-CURVE #1	1103	0-100%	0 %	
	ACCEL TIME #2	1104	0 to 3600 Seconds	3.0 SEC	
	DECEL TIME #2	1105	0 to 3600 Seconds	3.0 SEC	
	S-CURVE #2	1106	0-100%	0 %	
JOG SETTINGS	JOG SPEED	1201	0-MAX Speed	200 RPM	
	JOG ACCEL TIME	1202	0 to 3600 Seconds	3.0 SEC	
	JOG DECEL TIME	1203	0 to 3600 Seconds	3.0 SEC	
	JOG S-CURVE TIME	1204	0-100%	0 %	
KEYPAD SETUP	KEYPAD STOP KEY	1301	REMOTE ON (Stop key active during remote operation). REMOTE OFF (Stop key inactive during remote operation).	REMOTE ON	
	KEYPAD STOP MODE	1302	COAST, REGEN	COAST	
	KEYPAD RUN FWD	1303	ON, OFF	ON	
	KEYPAD RUN REV	1304	ON, OFF	ON	
	KEYPAD JOG FWD	1305	ON, OFF	ON	
	KEYPAD JOG REV	1306	ON, OFF	ON	

Parameter Block Values Level 1 Continued

Level 1 Blocks - Continued					
Block Title	Parameter	P#	Adjustable Range	Factory	User Setting
INPUT	OPERATING MODE	1401	KEYPAD STANDARD RUN 15SPD SERIAL BIPOLAR PROCESS MODE	KEYPAD	
	COMMAND SELECT	1402	POTENTIOMETER +/-10 VOLTS +/-5 VOLTS 4-20 mA 10V W/EXT CL 10V W/TORQ FF EXB PULSE FOL 5V EXB 10V EXB 4-20mA EXB 3-15 PSI EXB TACHOMETER EXB SERIAL NONE	+/-10 VOLTS	
	ANA CMD INVERSE	1403	ON, OFF	OFF	
	ANA 2 OFFSET	1404	-20% TO +20%	0.0	
	ANA 2 DEADBAND	1405	0-10.00 V	0.20 V	
OUTPUT	OPTO OUTPUT #1	1501	READY ZERO SPEED AT SPEED OVERLOAD KEYPAD CONTROL	READY	
	OPTO OUTPUT #2	1502	AT SET SPEED FAULT FOLLOWING ERR MOTR DIRECTION DRIVE ON	ZERO SPEED	
	OPTO OUTPUT #3	1503	CMD DIRECTION AT POSITION OVER TEMP WARN RUNNING FIELD	AT SPEED	
	OPTO OUTPUT #4	1504	PROCESS ERROR DRIVE RUN M/FWD CONTACT REV CONTACT	FAULT	
	ZERO SPD SET PT	1505	0-MAX Speed	200 RPM	
	AT SPEED BAND	1506	±1000 RPM	±100 RPM	
	SET SPEED	1507	0-MAX Speed	Rated Motor Speed	

Appendix B

Parameter Block Values Level 1 Continued

Level 1 Blocks - Continued					
Block Title	Parameter	P#	Adjustable Range	Factory	User Setting
OUTPUT (Continued)	ANALOG OUT #1	1508	ABS SPEED ABS TORQUE SPEED COMMAND FIELD CURRENT CMD FIELD CUR ARM CURRENT CMD ARM CUR FIRING ANGLE	ABS SPEED	
	ANALOG OUT #2	1509	ARM VOLTAGE FIELD VOLTAGE TORQUE POWER VELOCITY OVERLOAD POSITION LINE TIMER	ARM CURRENT	
	ANALOG #1 SCALE	1510	10-100%	100%	
	ANALOG #2 SCALE	1511	10-100%	100%	
	POSITION BAND	1512	0-32767 CNTS	CALC	
DC CONTROL	CTRL BASE VOLTS	1601	0-1000	CALC	
	FEEDBACK FILTER	1602	0-7	CALC	
	FEEDBACK DIR	1603	FORWARD, REVERSE	FORWARD	
	ARM PROP GAIN	1604	1-500	20	
	ARM INT GAIN	1605	0-30	10 Hz	
	SPEED PROP GAIN	1606	0-500	10	
	SPEED INT GAIN	1607	0-9.99 Hz	1.00 Hz	
	SPEED DIFF GAIN	1608	0-100	0	
	POSITION GAIN	1609	0-9999	CALC	
	IR COMP Gain	1610	0-1000	0	
	TACH TRIM	1611	90-110%	100%	
	NULL FORCE GAIN	1612	0-100	0	
FIELD CONTROL	FIELD PWR SUPPLY	1701	NONE, 15 AMP MAX, 40 AMP MAX	15 AMP MAX	
	FIELD ECON LEVEL	1702	0, 25 - 100%	67%	
	FORCING LEVEL	1703	100 - 125%	100%	
	FIELD SET SPEED	1704	0 - MAX RPM	0	
	FIELD STEP LIMIT	1705	0 - 5 SEC	0	
	FIELD REG GAIN	1706	0 - 255	40	
LEVEL 2 BLOCK	ENTERS LEVEL 2 MENU				
PRESS ENTER FOR PROGRAMMING EXIT	Exit programming mode and return to display mode.				

Parameter Block Values Level 2

Level 2 Blocks					
Block Title	Parameter	P#	Adjustable Range	Factory	User Setting
OUTPUT LIMITS	OPERATING ZONE	2001	ONE WAY	ONE WAY	
	MIN OUTPUT SPEED	2002	0-MAX Speed	0 RPM	
	MAX OUTPUT SPEED	2003	0-5000 RPM	Rated Motor Speed	
	PK CURRENT LIMIT	2004	0-PEAK RATED CURRENT	1.5 X Motor ARM Rating	
	CUR RATE LIMIT	2006	0.008-1.00 SEC	CALC	
CUSTOM UNITS	DECIMAL PLACES	2101	0-5	0	
	VALUE AT SPEED	2102	0-65535/1000 RPM	00000/ 01000 RPM	
	UNITS OF MEASURE	2103	Selection of 9 Character Sets	-	
PROTECTION	OVERLOAD	2201	FAULT, FOLDBACK	FOLDBACK	
	EXTERNAL TRIP	2202	ON, OFF	OFF	
	FOLLOWING ERROR	2203	ON, OFF	OFF	
	TORQUE PROVING	2204	ON, OFF	OFF	
MISCELLANEOUS	RESTART AUTO/MAN	2301	AUTOMATIC, MANUAL	MANUAL	
	RESTART FAULT/HR	2302	0-10	0	
	RESTART DELAY	2303	0-120 SECONDS	0 SEC	
	FACTORY SETTINGS	2304	YES, NO	NO	
	HOMING SPEED	2305	0-MAX Speed	100 RPM	
	HOMING OFFSET	2306	0-65535 CNTS	Encoder Counts	
SECURITY CONTROL	SECURITY STATE	2401	OFF, LOCAL, SERIAL, TOTAL SECURITY	OFF	
	ACCESS TIMEOUT	2402	0-600 SEC	0 SEC	
	ACCESS CODE	2403	0-9999	9999	
MOTOR DATA	ARMATURE VOLTAGE	2501	0-600 VOLTS	Factory Set	
	ARM RATED AMPS	2502	0-999.9	Factory Set	
	MOTOR RATED SPD	2503	0-5000 RPM	1750 RPM	
	MOTOR FIELD	2504	SHUNT, PERM MAGNET	SHUNT	
	MOTOR FIELD VOLTS	2505	0-600	CALC	
	MOTOR FIELD AMPS	2506	0-40	0.3	
	FEEDBACK TYPE	2507	ARMATURE, ENCODER, TACHOMETER, RESOLVER	ARMATURE	
	ENCODER COUNTS	2508	50-65535 CNTS	1024 PPR	
	RESOLVER POLES	2509	0 to 10	0	
	TACHOMETER VOLTS	2510	0 - 2000V PER 1000 RPM	50	
	PK POWER LIMIT	2511	50 - 300%	100	
	CALC PRESETS	2512	YES, NO	NO	

Appendix B

Parameter Block Values Level 2 Continued

Level 2 Blocks - Continued					
Block Title	Parameter	P#	Adjustable Range	Factory	User Setting
PROCESS CONTROL	PROCESS FEEDBACK	2601	POTENTIOMETER +/-10VOLTS +/-5 VOLTS 4-20mA 5V EXB 10V EXB 4-20mA EXB 3-15 PSI EXB TACHOMETER EXB NONE	NONE	
	PROCESS INVERSE	2602	ON, OFF	OFF	
	SETPOINT SOURCE	2603	SETPOINT CMD POTENTIOMETER +/-10VOLTS +/-5 VOLTS 4-20mA 5V EXB 10V EXB 4-20mA EXB 3-15 PSI EXB TACHOMETER EXB NONE	SETPOINT CMD	
	SETPOINT COMMAND	2604	-100% to +100%	0.0 %	
	SET PT ADJ LIMIT	2605	0-100%	10.0 %	
	PROCESS ERR TOL	2606	1-100%	10 %	
	PROCESS PROP GAIN	2607	0-200	0	
	PROCESS INT GAIN	2608	0-9.99 HZ	0.00 HZ	
	PROCESS DIFF GAIN	2609	0-1000	0	
	FOLLOWER I:O RATIO	2610	(1-65535):(1-20)	1:1	
FOLLOWER I:O OUT	2611	1-65535	1		
MASTER ENCODER	2612	50-65535	1024		

Parameter Block Values Level 2 Continued

Level 2 Blocks - Continued					
Block Title	Parameter	P#	Adjustable Range	Factory	User Setting
AUTO-TUNING	CALC PRESETS	CALC	YES, NO	NO	
	CMD OFFSET TRM Measures and trims out offset voltage at Analog Input #2 (J1-4 & J1-5).	AU1	-	-	
	CUR LOOP COMP Measures current response while running motor at one half the rated motor current.	AU2	-	-	
	FEEDBACK TESTS This procedure checks the values entered in Encoder Counts, Resolver Poles and Feedback direction. This is accomplished by accelerating the motor "open loop", detecting the phasing of encoder feedback and counting the number of encoder pulses per revolution of the motor. It also check for output when a DC tach is specified and sets the feedback direction. Press the ENTER key to run auto tuning test. Not required for ARMATURE FEEDBACK.	AU3	-	-	
	SPD CNTRLR CALC Measures the motor current to acceleration ratio during motor rotation. This procedure adjusts the Process INT Gain and Process DIFF Gain parameters.	AU4	-	-	
LEVEL 1 BLOCK	Enters Level 1 Menu				
PRESS ENTER FOR PROGRAMMING EXIT	Exit programming mode and return to display mode.				

Appendix C

Remote Keypad Mounting Template

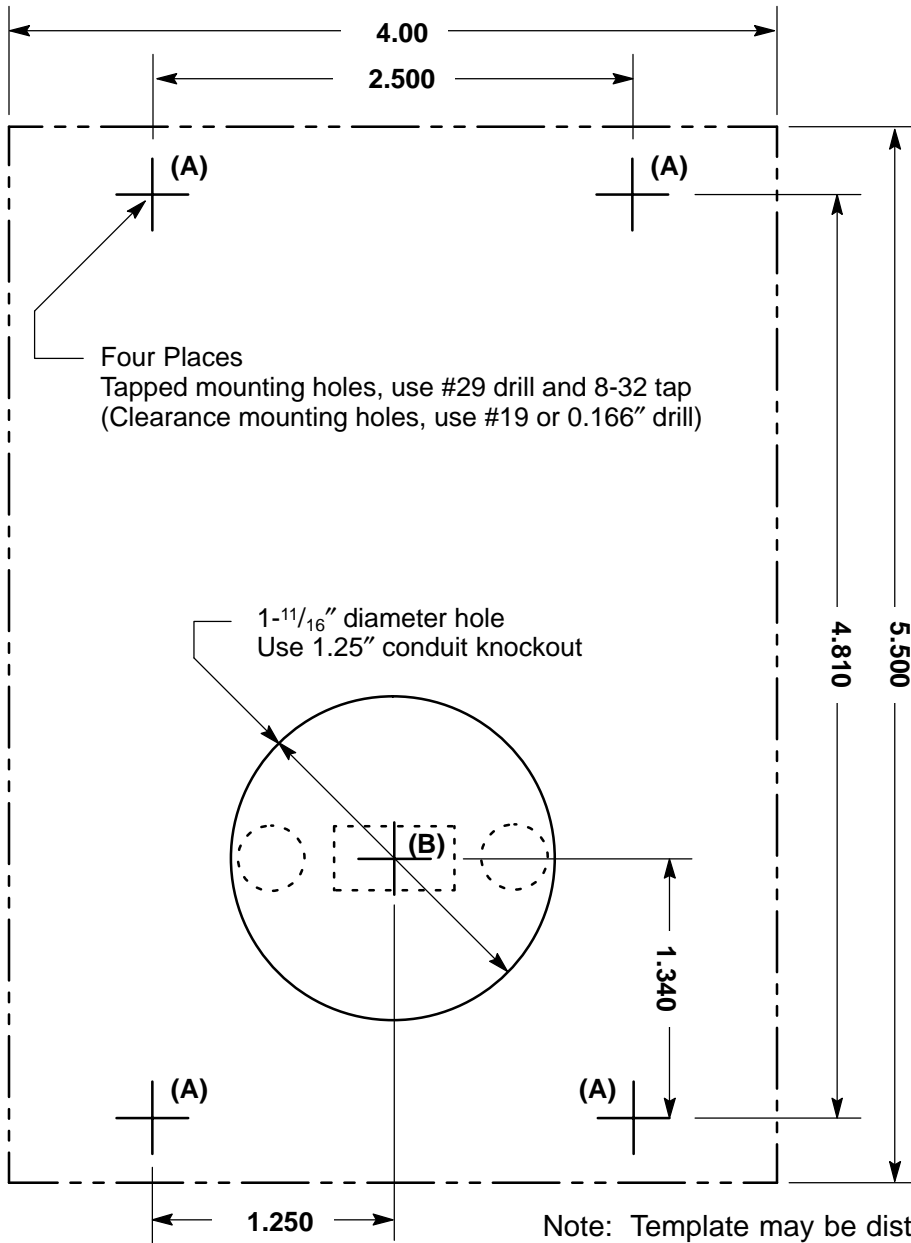

BALDOR[®]
MOTORS AND DRIVES

BALDOR ELECTRIC COMPANY
P.O. Box 2400
Ft. Smith, AR 72902-2400
(501) 646-4711
Fax (501) 648-5792

© Baldor Electric Company
MN719

Printed in USA
10/99 C&J2500

М41А04

Series 19H Digital DC SCR Control

MN719